

*Wiring-reduction Units
that allow several switching
signals to be transmitted
over just 2 wires*

**B7A
Link Terminals**

Table of Contents

<input type="checkbox"/>	I/O Combinations
	I/O Combination Models
	10-point Terminal Models
	CQM1 B7A Interface Units
	CS1 and C200HX/C200HG/C200HE/C200HS/C200H B7A Interface Units
<input type="checkbox"/>	Connection Examples
	Connection with CQM1H/CQM1
	Connection with CS1/ SYSMAC C200HX/C200HG/C200HE/C200H/C200HS
	Connection with CVM1/CV Series
<input type="checkbox"/>	Line of Products
	B7AS Link Terminals with 32 Inputs
	B7A/B7AS Link Terminals with 16 I/O Points (Screw Terminal and Modular Models)
	B7A Link Terminals with PLC Connectors (16 and 32 I/O Points)
	G70D-B7A Link Terminals with 16 Relay Outputs
	B7AM-6BS Link Terminal with 16 Inputs and 16 Outputs
	B7AM-8 Link Terminals with 8 Inputs and 8 Outputs
	B7AH Hybrid IC Link Terminals
	B7AC Link Terminals with Sensor I/O Connectors
	DRT1-B7AC B7AC Interface Terminal (10 Inputs × 3)
	B7A Link Terminals with 10 I/O Points
	CQM1-B7A B7A Interface Units for CQM1/CQM1H PLCs
	C200H-B7A B7A Interface Units for CS1/C200HS/HX/HG/HE PLCs
	B7AP Power Couplers
	Product List

Five Types and 55 Models Can Be Combined Freely for a Variety of Applications to Save Wiring Effort

Ordering Information

■ I/O Combinations

32-point models (screw terminal models), 16-point models (screw terminal models, modular models, and hybrid IC models), PLC connector models (16-point models and 32-point models), I/O combination models (16-input/16-output models and 8-input/8-output models), 10-point models (screw terminal models, modular models, and sensor I/O connector models), and Interface Units for PLCs (CQM1 and C200H/HS) are available for a variety of applications.

32-point, 16-point, and PLC Connector Models

Output (reception)		Screw terminal models (16 points)	Screw terminal models with relay outputs (16 points)	Modular models (16 points)	Hybrid IC models (16 points)	PLC connector models (16 points)	PLC connector models (32 points)
Input (transmission)		B7A, B7AS	G70D-R6-B7A	B7A	B7AH	B7A	B7A
Screw terminal models (32 points)	B7AS	A	A	A	A	A	B
Screw terminal models (16 points)	B7A, B7AS	B	B	B	B	B	A
Modular models (16 points)	B7A						
Hybrid IC models (16 points)	B7AH						
PLC connector models (16 points)	B7A						
PLC connector models (32 points)	B7A	A	A	A	A	A	B

Note: Only normal I/O delay time (typically 19.2 ms) is available.

Meaning of "A" and "B"

A: Combinations with one 32-point model connected to two 16-point models.

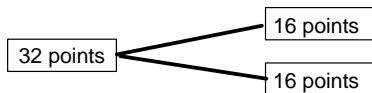





B: One-to-one combinations of models with the same number of input or output points.





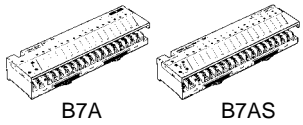

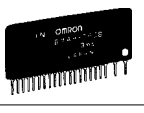
Note: With 32-point models, 16-point models, and PLC connector models, two I/O delay time settings are available: high-speed (typically 3 ms) and normal (typically 19.2 ms). Use the same settings for combined Terminals.

I/O Combination Models

Input (Transmission)

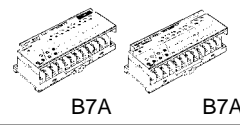
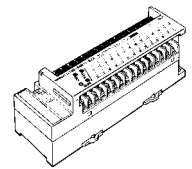
Screw terminal model (16 points)	
Modular model (16 points)	
PLC connector model (16 points) Hybrid IC model (16 points)	
PLC connector model (32 points)	 Note: Two B7AM Terminals are required for 32 inputs.

Output (Reception)

Screw terminal model (16 points)	
Screw terminal model with relay outputs (16 points)	 Note: Only normal I/O delay time (typically 19.2 ms) is available.
Modular model (16 points)	
PLC connector model (16 points) Hybrid IC model (16 points)	
PLC connector model (32 points)	 Note: Two B7AM Terminals are required for 32 outputs.

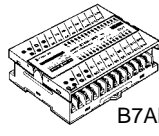
I/O combination screw terminal model (16 inputs, 16 outputs)		
Output		Input

Set the I/O delay time setting switch to the setting of B7A Terminals used in combination.

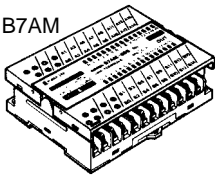
Screw terminal model (16 input and 16 output points)		Input
		Output

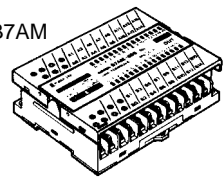
Screw terminal model (16 input and 16 output points)	Output	
	Input	

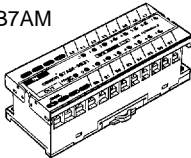
Screw terminal model (8 input and 8 output points)		Input
		Output

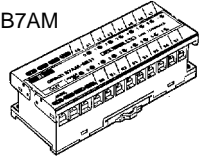
Screw terminal model (8 input and 8 output points)	Output	
	Input	

10-point Terminal Models

Input (Transmission)

Screw terminal model (10 points)

B7A

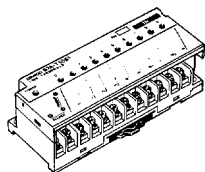

Modular model (10 points)

B7A



FA connector model (10 points)

B7AC

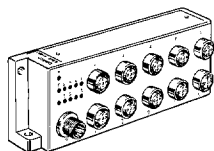

Output (Reception)

Screw terminal model (10 points)

B7A

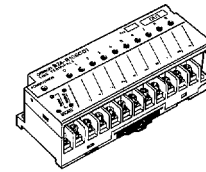

Modular model (10 points)

B7A



DeviceNet model

DRT1-B7AC



Note: The 10-point model has a normal I/O delay time of 19.2 m (typical); 10-point models with short I/O delay time are not available. The transmission signals of the 16-point PLC connector model are not compatible with those of the 10-point model. Therefore 16-point PLC connector models and 10-point models cannot be used in combination.

CQM1 B7A Interface Units

16-point Input (Transmission) Models

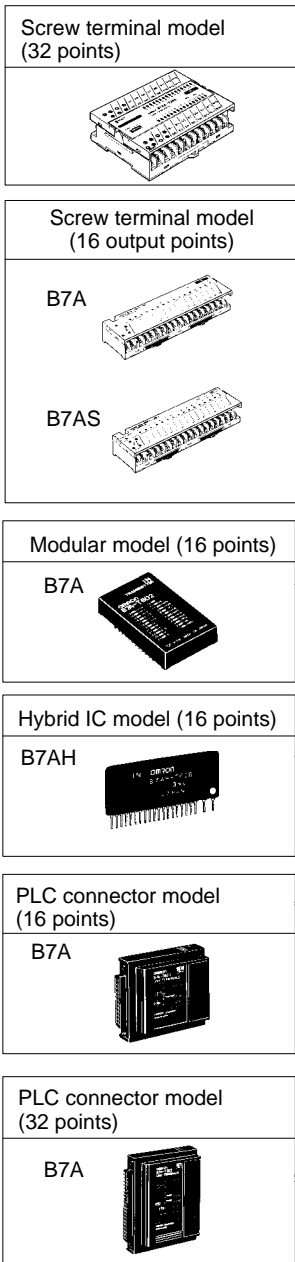

CQM1 Series

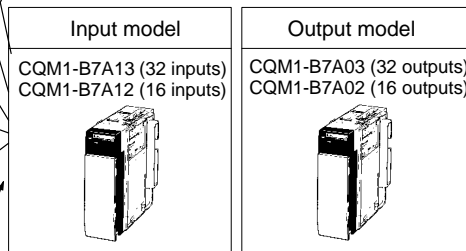
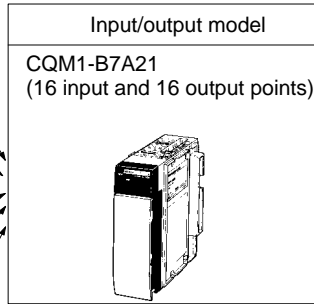

Note: Two 16-type models can be used to connect to 32-point models.

16-point Output (Reception) Models

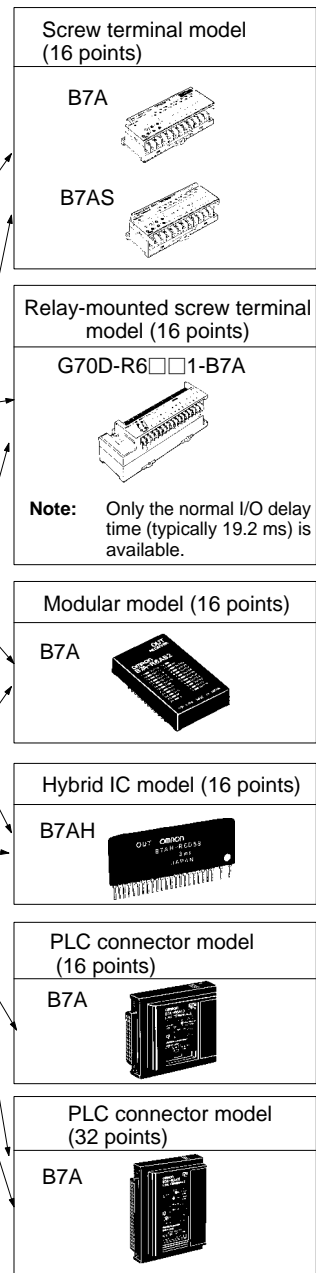

Note: Use combinations of B7A Interface Units and B7A Link Terminals with the same I/O delay time. The I/O delay time (high speed: typically 3 ms; normal speed: typically 19.2 ms) can be switched for B7A Interface Units and 32-point B7A screw terminal models using a selection switch. Set the same I/O delay time for connected Units.

CS1 and C200HX/C200HG/C200HE/C200HS/C200H B7A Interface Units

16-point Input (Transmission) Models

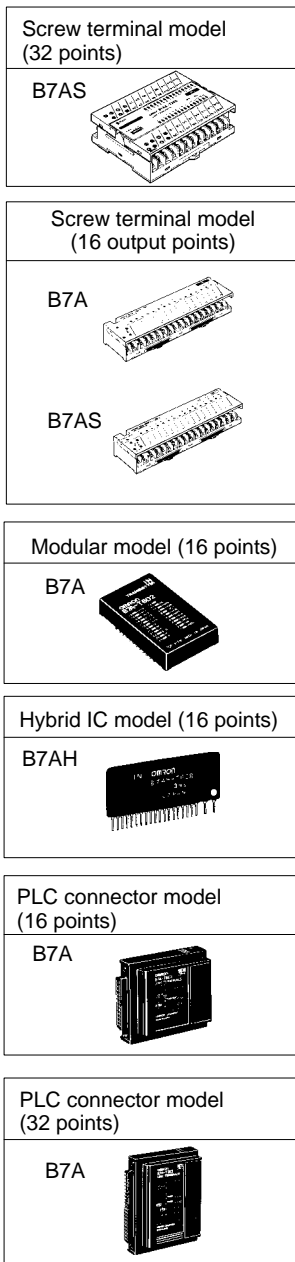

CS1/C200H Series

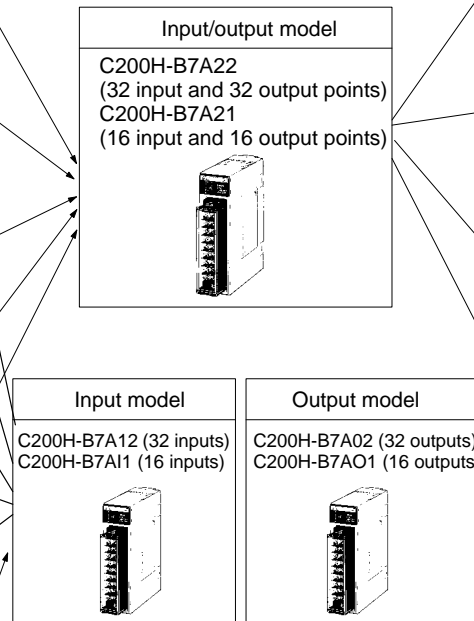

Note: Two 16-type models can be used to connect to 32-point models.

16-point Output (Reception) Models

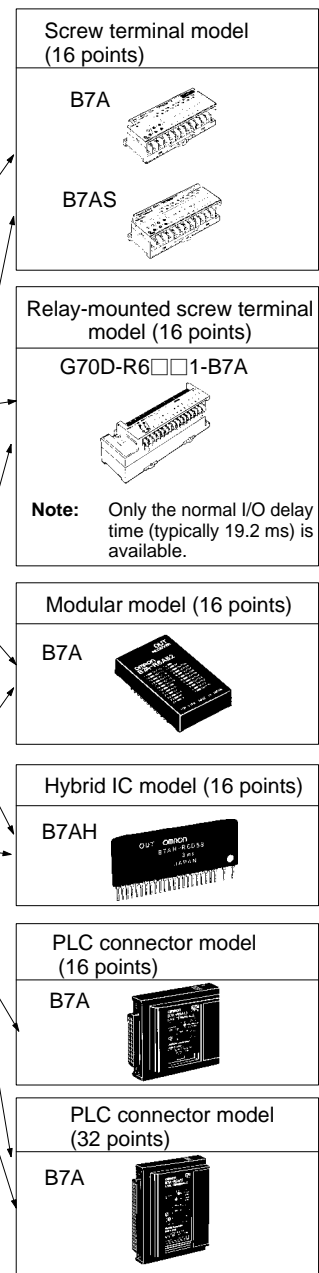

Note: Use combinations of B7A Interface Units and B7A Link Terminals with the same I/O delay time. The I/O delay time (high speed: typically 3 ms; normal speed: typically 19.2 ms) can be switched for B7A Interface Units (except for C200H-B7A11 and C200H-B7A01) and 32-point B7A screw terminal models using a selection switch. Set the same I/O delay time for connected Units.

Operation

■ Connection Examples Connection with CQM1H/CQM1

CQM1 B7A Interface Unit

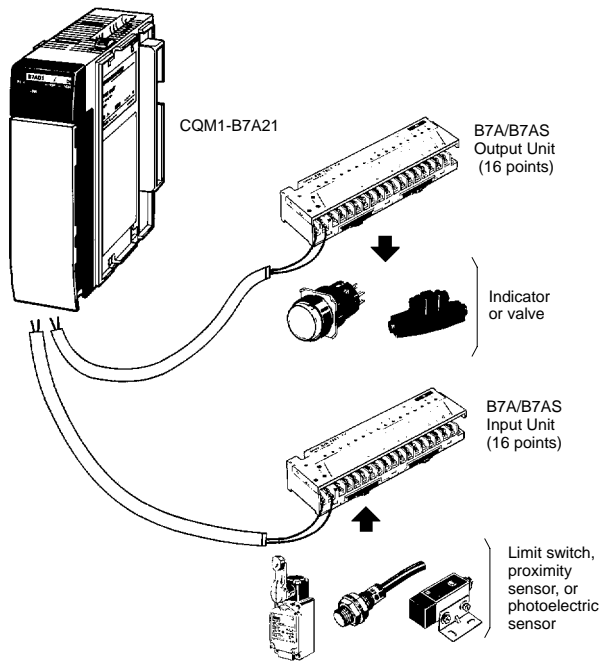

CQM1 Connecting Terminals

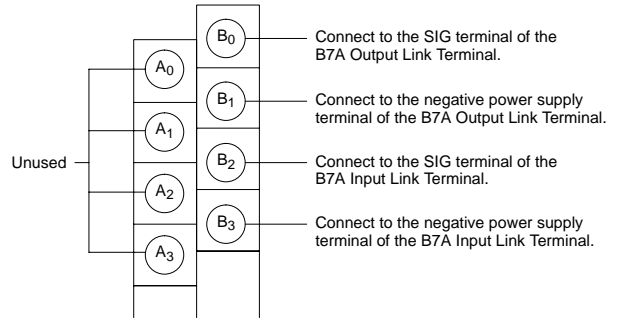

CQM1 I/O Unit

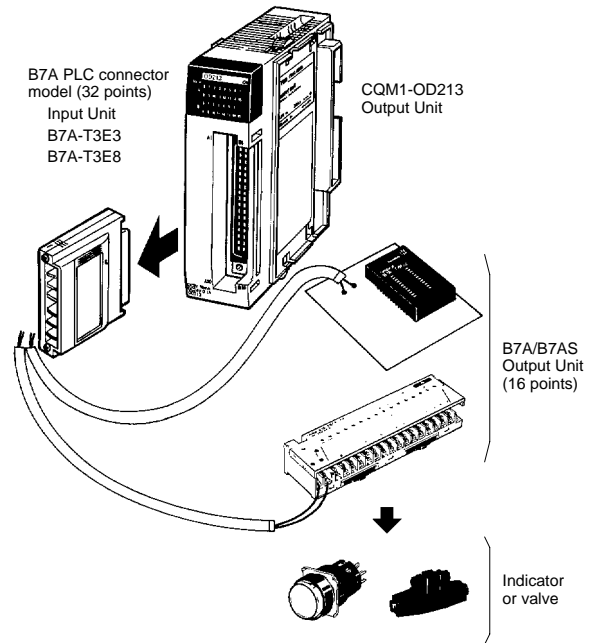
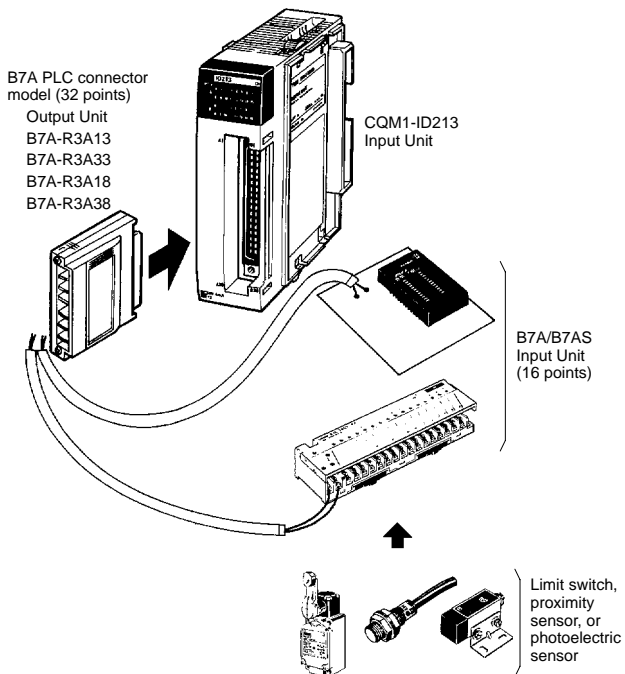

Connection with CS1/SYSMAC C200HX/C200HG/C200HE/C200H/C200HS

C200H B7A Interface Unit

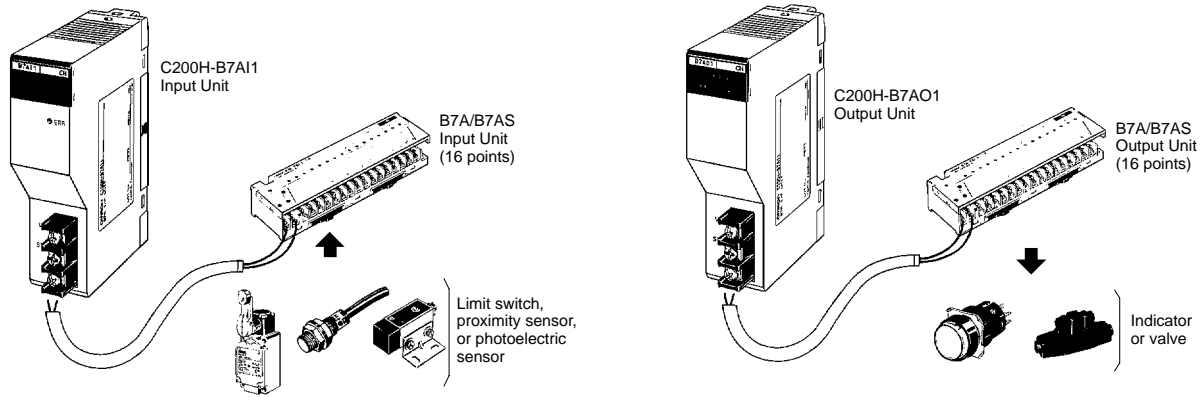

C200H I/O Unit

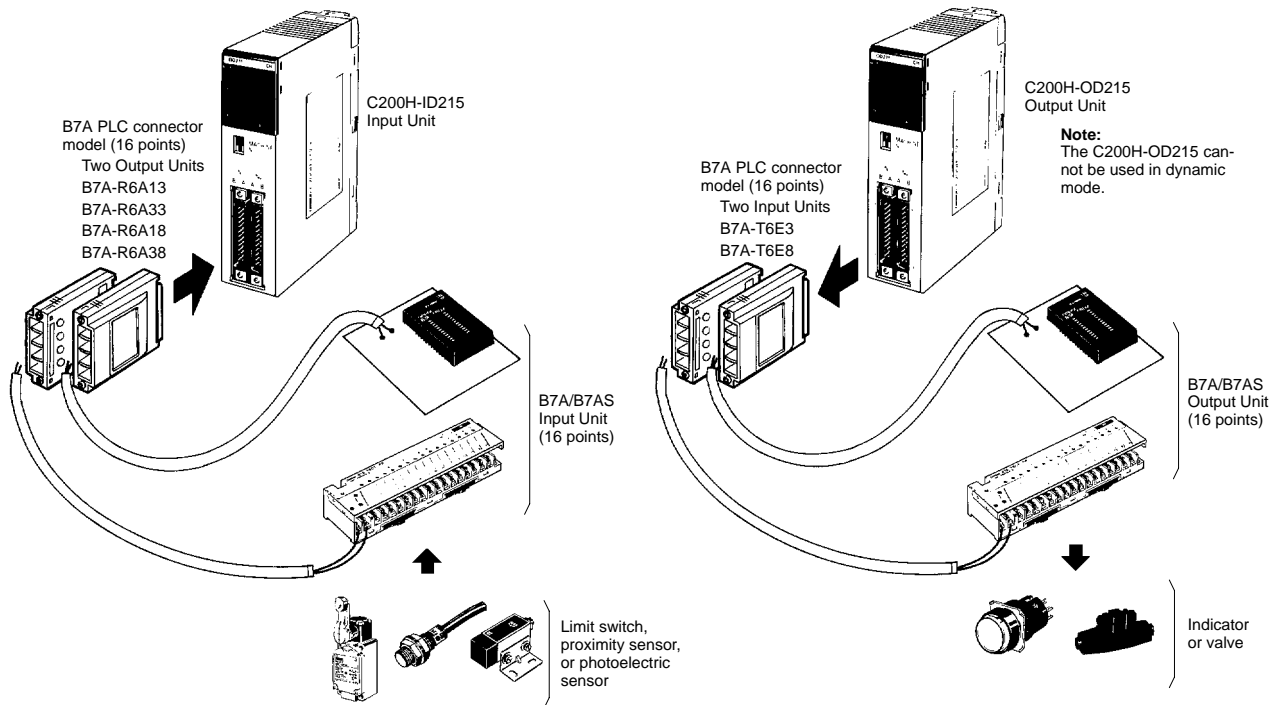

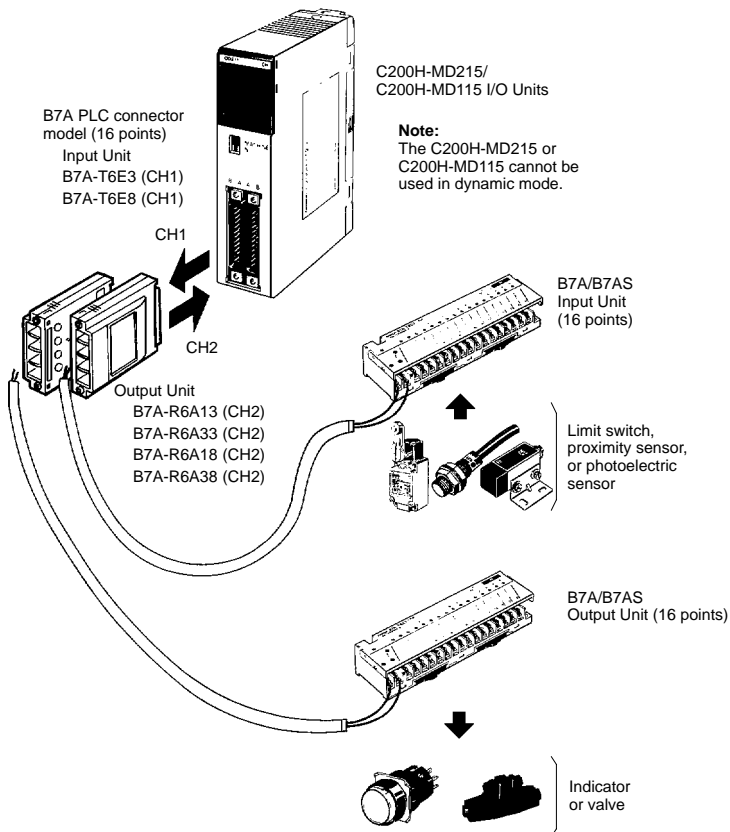

C200H Multi-point I/O Unit (Group 2)

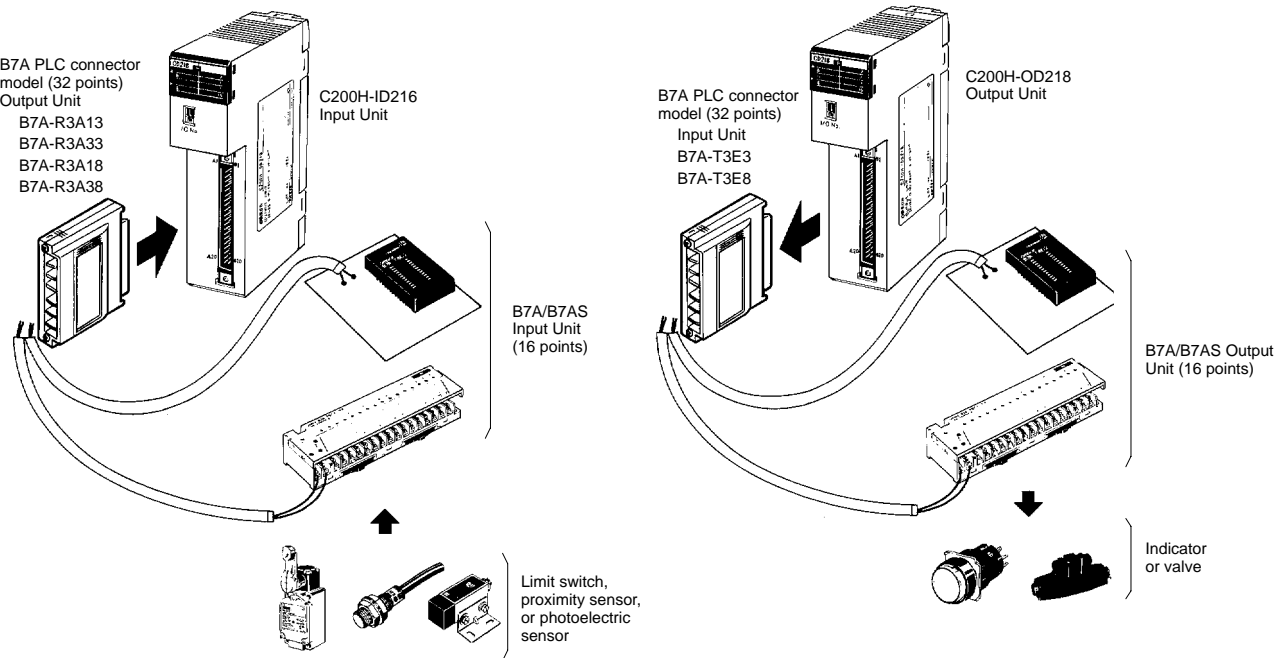

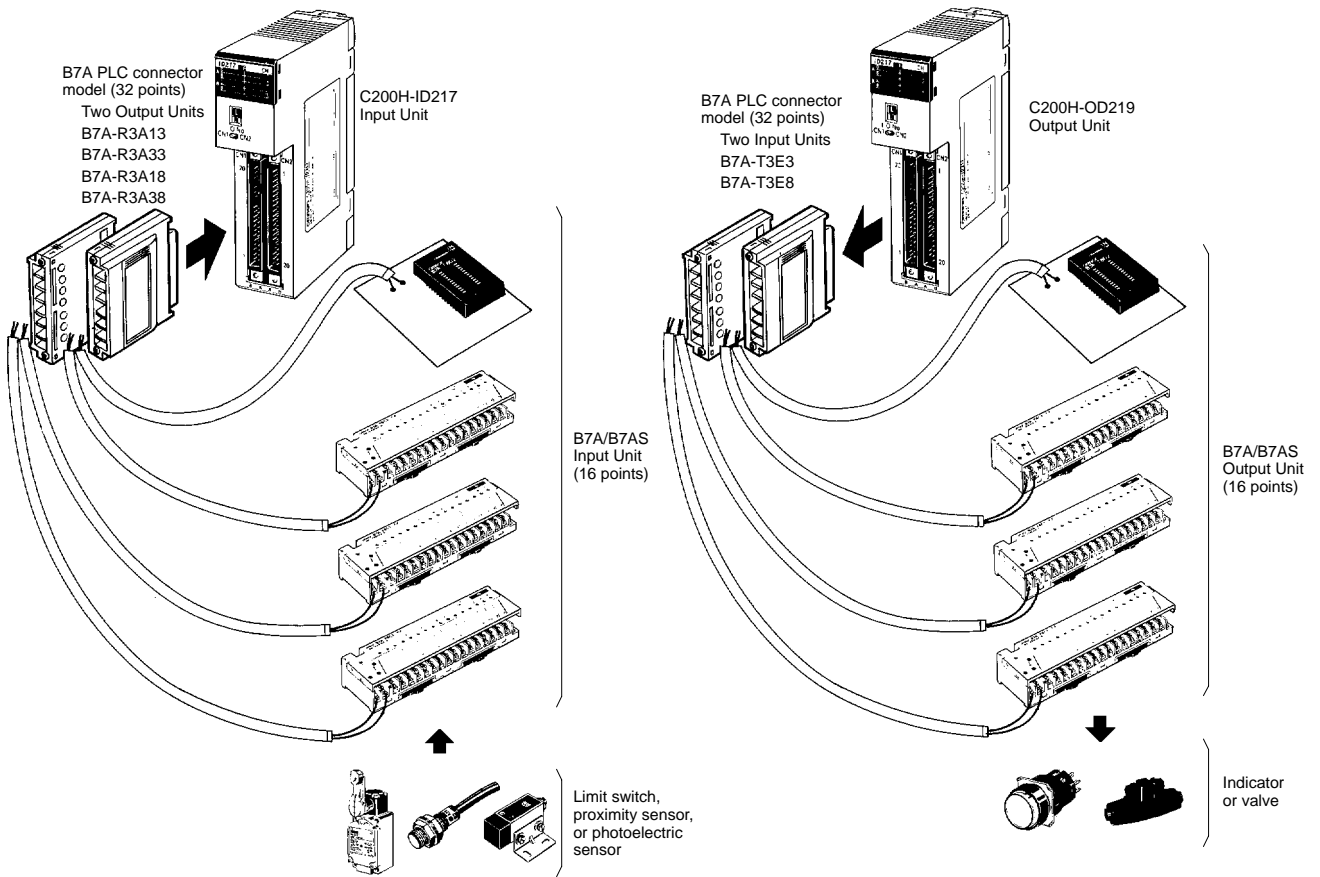

Connection with CVM1/CV Series

C500 I/O Unit

Note: The 3G2A5-OD215 cannot be connected due to the difference in terminal arrangement.

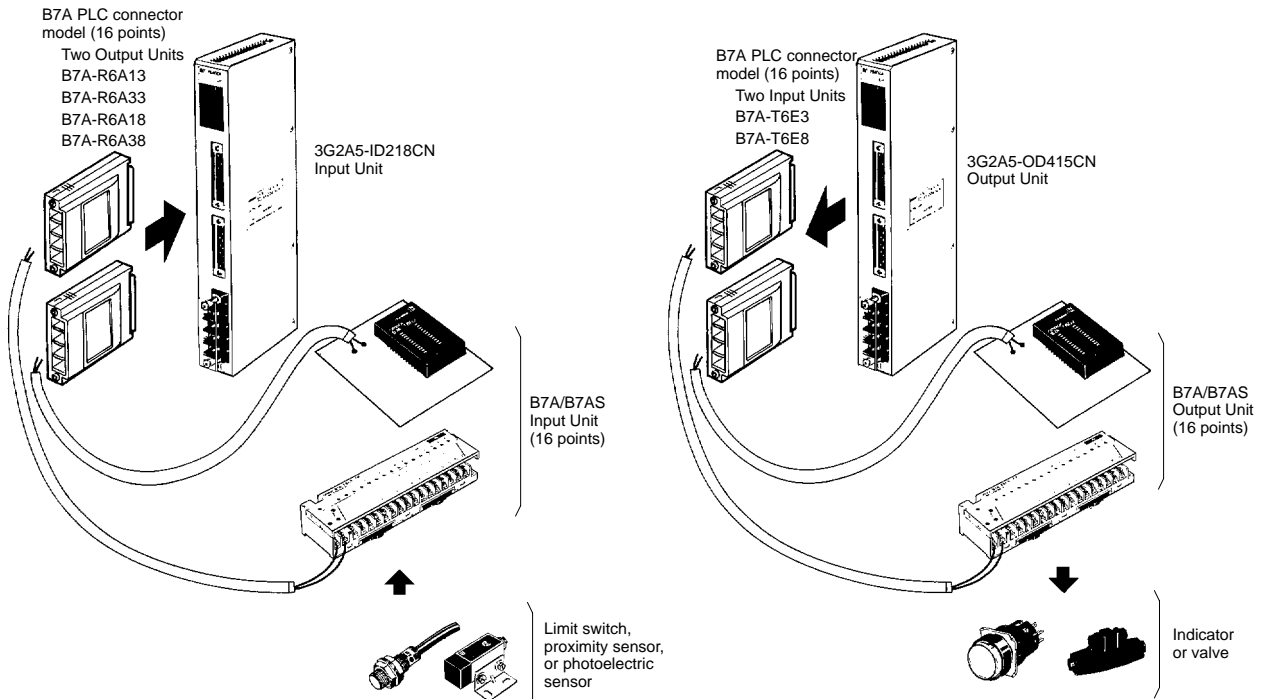

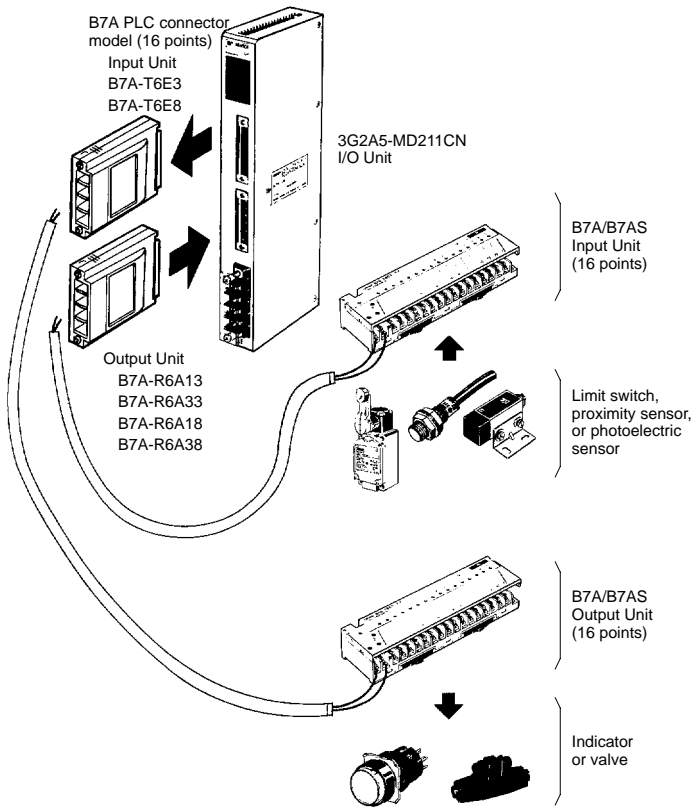

C500 I/O Unit

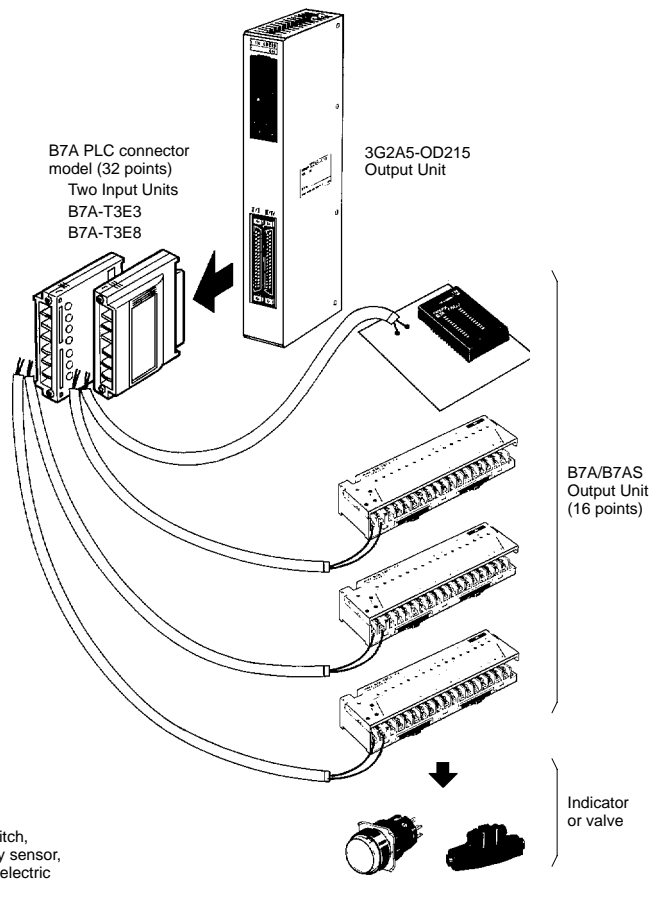
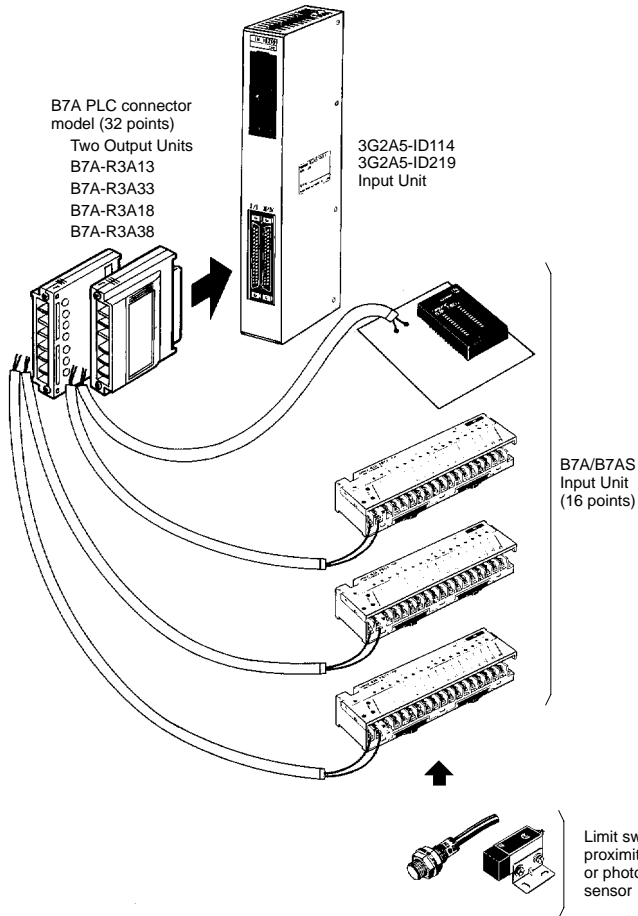

Incorporates 2 Sets of 16 Input Points in a Single Unit

- Select either normal I/O delay time or short I/O delay time using a switch.
- Compact dimensions contribute to space savings.
- Use for either contact or no-contact inputs.



Ordering Information

■ Model Number Legend

B7AS - T 3 B S
1 2 3 4 5

1. Series

S: Small

2. Input/Output Classification

T: Input

3. Number of I/O Points

3: 32

4. Input Logic/Internal I/O Common

B: NPN compatible

5. Appearance

S: Screw terminals

■ Product List

Refer to page 114 for details.

■ I/O Combinations

Refer to pages 1 to 5 for details.

Specifications

■ Characteristics

General

	Normal speed	High speed
Communications method	Unidirectional, time-division multiplex	
Transmission distance	500 m max.	100 m max. (see note 1)
I/O delay time	Typical: 19.2 ms; 31 ms max.	Typical: 3 ms; 5 ms max.
Minimum input time (see note 2)	16 ms	2.4 ms
Operating voltage range	12 to 24 VDC (10.8 to 26.4 VDC)	
Insulation resistance	100 M Ω min. (500 V) between each terminal and external parts	
Dielectric strength	1,000 VAC, 50/60 Hz for 1 min between each terminal and external parts	
Noise immunity (see note 3)	Noise level: 1.5 kV; pulse width: 100 ns to 1 μ s (on transmission line due to coupling)	
Vibration resistance	10 to 55 Hz, 1.5-mm double amplitude	
Shock resistance	300 m/s ²	
Ambient temperature	Operating: -10 to 55°C (with no icing or condensation) Storage: -25 to 65°C (with no icing or condensation)	
Ambient humidity	Operating: 35% to 85% (with no condensation)	

Note: 1. A shielded transmission cable or a VCTF cable with a thickness of 0.75 mm² minimum must be used for signal transmission. If the VCTF cable is used, however, the transmission distance will be 10 m maximum regardless of whether or not independent power supplies for the Input and the Output Link Terminals are used.

2. The minimum input time is required for the B7A/B7AS to read an input signal.

3. For high-speed models, these values are possible without grounding the shielded line.

Input Models

Item	B7AS-T3BS
Compatible inputs (see note 1)	Switches, two-wire sensors with DC output, three-wire NPN sensors
Input logic	Active low
I/O delay time	Normal speed (typical 19.2 ms); high speed (typical 3 ms) (see note 3)
Current consumption (see note 2)	240 mA max. with all input terminals ON
Operating voltage range	12 to 24 VDC
Input voltage range	0 VDC to supply voltage
Input current range	-6 to -3 mA/point (see note 4)
Minimum input time	Normal speed: 16 ms; high speed: 2.4 ms
ON/OFF threshold	No-contact input: ON discrimination voltage: 4 V max. OFF discrimination voltage: 6 V min. Contact input: ON discrimination resistance: 660 Ω max. OFF discrimination resistance: 2 k Ω min.
Mounting strength	No damage when 49-N pull is applied for 1 min each in all directions (except in direction of DIN track)
Terminal strength	No damage when 49-N pull is applied each in all directions
Tightening torque	0.78 to 1.18 N • m
Weight	Approx. 230 g

Note: 1. Two-wire sensors must satisfy the following requirements:

Residual voltage:

4 V max.

Current leakage:

1.5 mA max.

The lower limit of control output: 3 mA (Use a bleeder resistor to eliminate this restriction.)

2. Consumption when all 32 points are ON. Excludes external sensor current consumption.

3. Factory-set to normal speed (typical 19.2 ms).

4. The minus sign indicates that the current is flowing out from input terminals.

Nomenclature

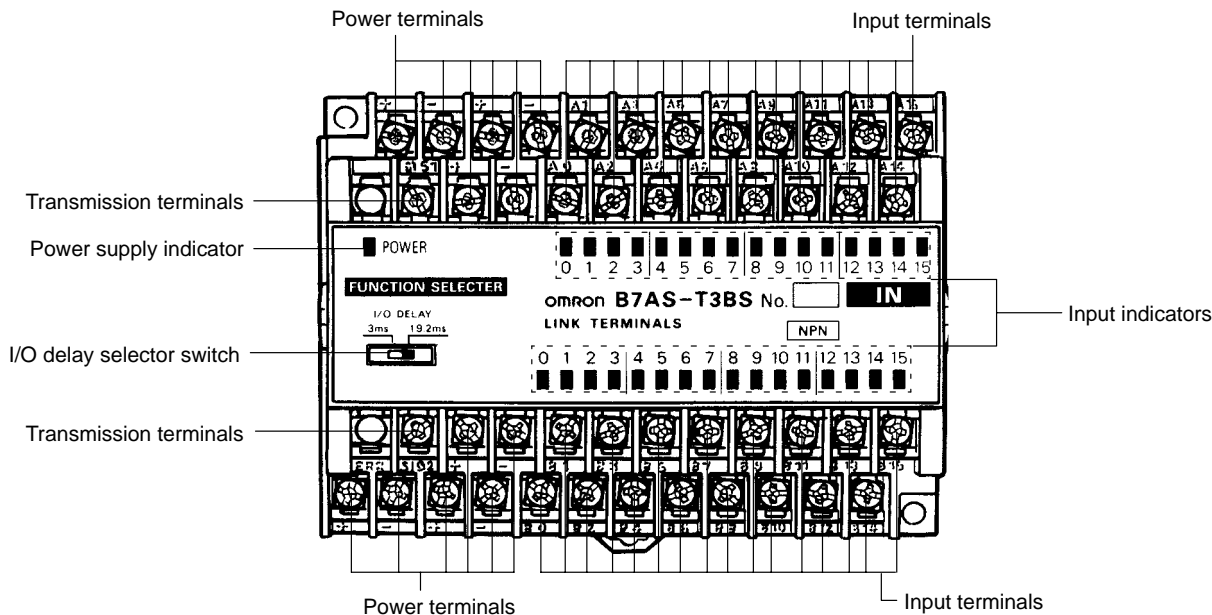

Recommended Solderless Terminals

Wire	JIS specifications
0.75 mm ² (AWG#18)	RAV 1.25 to 3.5 (vinyl-insulated round wire) or RAP 1.25 to 3.5 (nylon-insulated round wire)
1.25 mm ² (AWG#16)	

Indicator Operation

Indicator	Function	
POWER (input side)	G	Lit when power is supplied and the Terminal is operating.
	N	Not lit when power is not supplied.
Input indicator	O	Lit when the input signals are ON.
	N	Not lit when the signals are OFF.

Note: G: Green indicator lit; O: Orange indicator lit; N: Not lit

I/O Delay Selector Switch

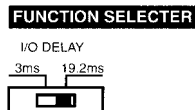

I/O delay selector switch	
3 ms	19.2 ms
High speed (typical: 3 ms)	Normal speed (typical: 19.2 ms)

Note: Set the I/O delay time to the same setting as the Output Unit. The factory setting is 19.2 ms.

Operation

■ Power Supply

The 6 positive and 6 negative power supply terminals are respectively connected internally. Use any positive and negative terminals for the power supply and any negative terminal for the negative signal line.

I/O Delay: Normal Speed (Connect Independent Power Supplies)

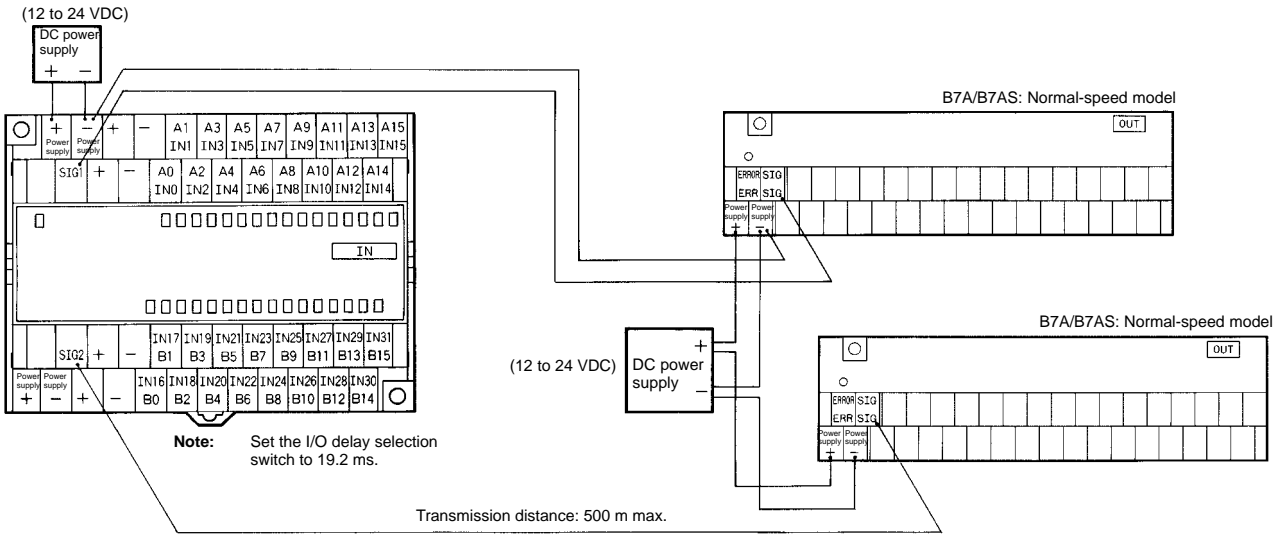

Note: Use a VCTF transmission cable of thickness 0.75 mm min.

I/O Delay: High Speed (Connect Independent Power Supplies)

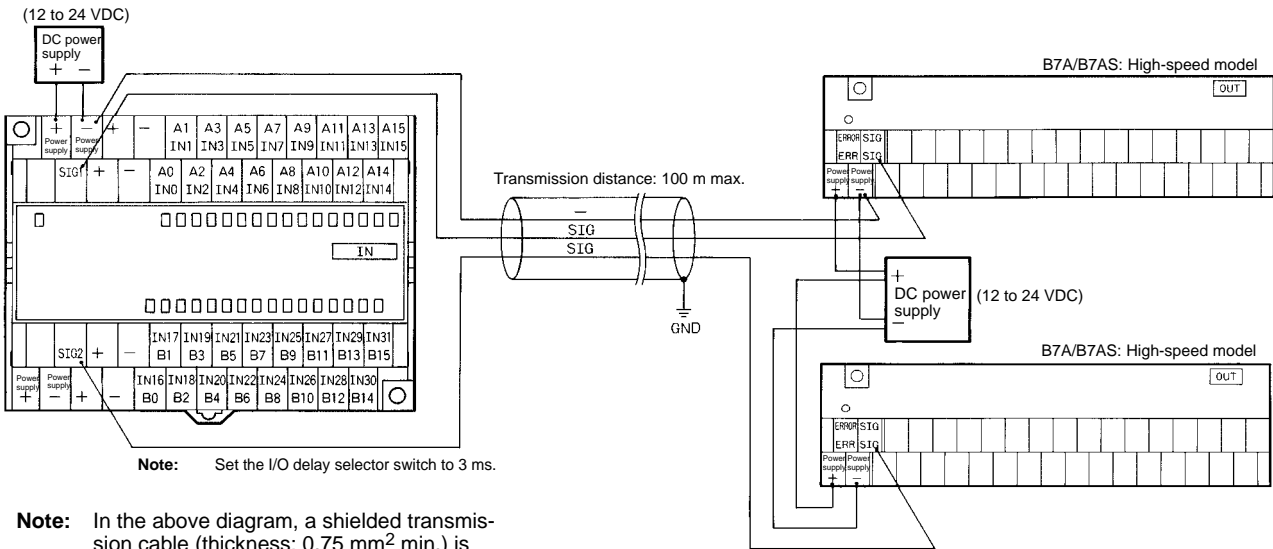

Note: In the above diagram, a shielded transmission cable (thickness: 0.75 mm² min.) is used. Connect the shield line to ground (do not connect to the negative power supply terminals).

Dimensions

Note: All units are in millimeters unless otherwise indicated.

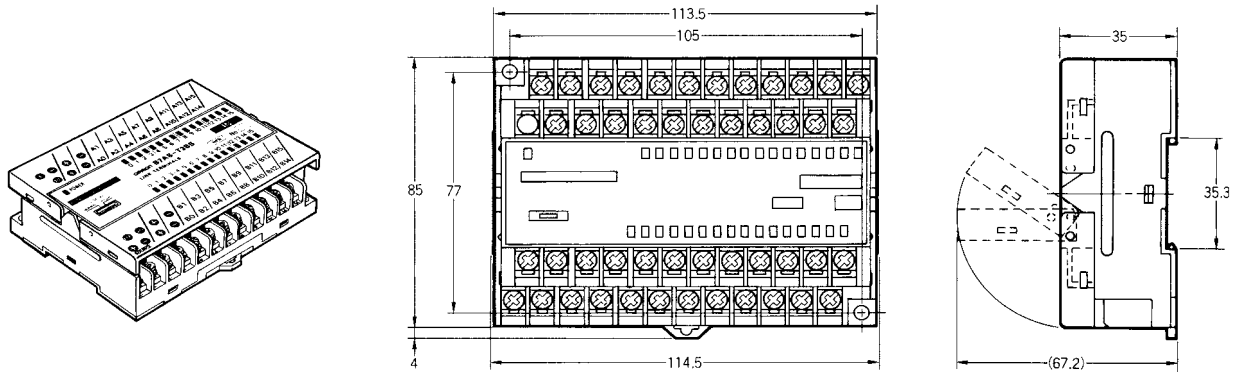

Installation

Internal Circuits and Terminal Arrangement

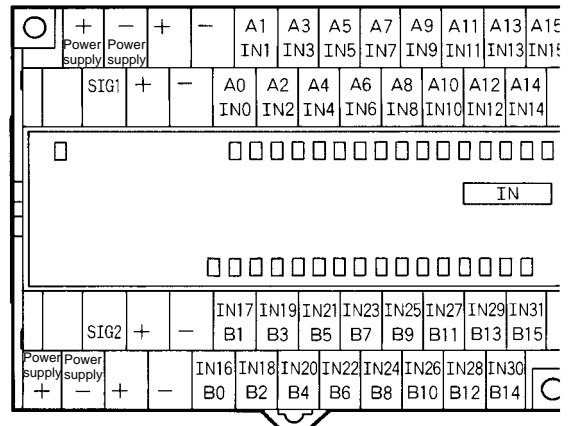
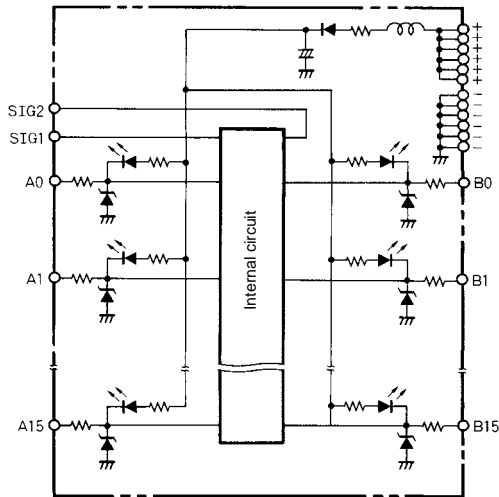

Transmit Signals while Saving Space and Wiring Effort

- More economical than previous multipoint transmission terminals.
- Transmit 16 input signals over just 2 wires (or 3 wires if only one Terminal has power supply.)
- Models available with normal I/O delay time (19.2 ms typical) or short I/O delay time (3 ms typical).
- Models available with the HOLD function or LOAD OFF function for processing transmission errors.
- A series of B7AS models as compact as 10-point screw terminal models are available.



Ordering Information

■ Model Number Legend

Input Models

B7A□ - T 6 □ □
 1 2 3 4 5

1. Series

None: Standard
 S: Small

2. Input/Output Classification

T: Input

3. Number of I/O Points

6: 16

4. Input Logic/Internal I/O Common

4	Input logic	Internal I/O common
A	NPN compatible	- common
B	NPN compatible	+/- common
C	PNP compatible	+/- common
D	PNP (TTL) compatible	---

5. I/O Delay Time (Typical)/Appearance

5	I/O delay time	Appearance
1	19.2 ms	Screw terminals
2	19.2 ms	Module
6	3 ms	Screw terminals
7	3 ms	Module

Output Models

B7A□ - R 6 □ □ □
 1 2 3 4 5 6

1. Series

None: Standard
 S: Small

2. Input/Output Classification

R: Output

3. Number of I/O Points

6: 16

4. Output Logic/Output Capacity

3	Output logic	Output capacity
A	NPN open collector	0.05 A/point
B	NPN open collector	0.1 A/point
C	NPN open collector	0.5 A/point
F	PNP open collector	0.1 A/point
G	PNP open collector	0.5 A/point

5. Error Processing

1: HOLD
 3: LOAD OFF
 5: HOLD/LOAD OFF

6. I/O Delay Time (Typical)/Appearance

5	I/O delay time	Appearance
1	19.2 ms	Screw terminals
2	19.2 ms	Module
6	3 ms	Screw terminals
7	3 ms	Module

■ Product List

Refer to page 114 for details.

■ I/O Combinations

Refer to pages 1 to 5 for details.

Specifications

■ Characteristics

General

	Normal speed	High speed
Communications method	Unidirectional, time-division multiplex	
Transmission distance (see note 1)	500 m max.	100 m max. (see note 2)
I/O delay time	Typical: 19.2 ms; 31 ms max.	Typical: 3 ms; 5 ms max.
Minimum input time (see note 3)	16 ms	2.4 ms
Operating voltage range	12 to 24 VDC (10.8 to 26.4 VDC) (see note 1)	
Insulation resistance	100 MΩ min. (500 V) between each terminal and external parts	
Dielectric strength	1,000 VAC, 50/60 Hz for 1 min between each terminal and external parts	
Noise immunity (see note 4)	Noise level: 1.5 kV; pulse width: 100 ns to 1 μs (on transmission line due to coupling)	
Vibration resistance	10 to 55 Hz, 1.5-mm double amplitude	
Shock resistance	300 m/s ²	
Ambient temperature	Operating: -10 to 55°C (with no icing) Storage: -25 to 65°C (with no icing)	
Ambient humidity	Operating: 35% to 85% (with no condensation)	

- Note:**
1. The transmission distance values stated in this table are possible if the Input or Output Link Terminal is connected to an independent power supply. If a single power supply is connected to the Input or Output Link Terminal, the supply voltage must be 24 VDC ±10%, in which case the transmission distance of a normal-speed model is 100 m maximum and that of a high-speed model is 50 m maximum. Refer to *Power Supply* on page 21 for details.
 2. A shielded transmission cable or a VCTF cable with a thickness of 0.75 mm² minimum must be used for signal transmission. If the VCTF cable is used, however, the transmission distance will be 10 m maximum regardless of whether or not independent power supplies for the Input and the Output Link Terminals are used.
 3. The minimum input time is required for the B7A/B7AS to read an input signal.
 4. For high-speed models, these values are possible without grounding the shielded line.

Input Models

Item	Screw terminal models		
	B7A-T6A1/-T6A6	B7A-T6B1/-T6B6	B7AS-T6B1/-T6B6
Compatible inputs (see note 1)	Switches, two-wire sensors with DC output, three-wire NPN sensors		
Input logic	Active low		
I/O delay time	B7A□-T6□1: normal speed (typical 19.2 ms); B7A□-T6□6: high speed (typical 3 ms)		
Current consumption (see note 2)	120 mA max. with all input terminals ON		
Operating voltage range	12 to 24 VDC		
Input voltage range	0 VDC to supply voltage		
Input current range	-6 to -3 mA/point (current flowing from input terminals)		
Minimum input time	B7A□-T6□1: 16 ms; B7A□-T6□6: 2.4 ms		
ON/OFF threshold	No-contact input: ON voltage: 4 V max. OFF voltage: 6 V min. Contact input: ON discrimination resistance: 660 Ω max. OFF discrimination resistance: 2 kΩ min.		
Mounting strength	No damage when 49-N pull is applied for 1 min each in all directions (except in direction of DIN track)		
Terminal strength	No damage when 49-N pull is applied each in all directions		
Tightening torque	0.78 to 1.18 N • m		
Weight	Approx. 160 g		Approx. 130 g

- Note:**
1. All B terminals of the B7A-T6A□ are negative terminals; power must be supplied to the three-wire sensor via the positive power supply terminal or from an independent power supply.
Two-wire sensors must satisfy the following requirements:
 Residual voltage: 4 V max.
 Current leakage: 1.5 mA max.
 The lower limit of control output: 3 mA (Use a breeder resistor to eliminate this restriction.)
 2. Consumption when all 16 points are ON. Excludes external sensor current for Input Terminals.

Item	Screw terminal models	Modular models	Compact modular models
	B7A-T6C1/-T6C6	B7A-T6D2/-T6D7	B7A-T6D7-D
Compatible inputs	Switches, two-wire sensors with DC output, 3-wire PNP sensors	TTLs, switches, 3-wire PNP sensors (see note 2)	TTLs, switches, 3-wire PNP sensors
Input logic	Active high		Active low
I/O delay time	B7A-T6C1: normal speed (typical 19.2 ms); B7A-T6C6: high speed (typical 3 ms)	B7A-T6D2: normal speed (typical 19.2 ms); B7A-T6D7: high speed (typical 3 ms)	---
Current consumption (see note 3)	120 mA max. with all input terminals ON	60 mA max. with all input terminals ON	
Operating voltage range	12 to 24 VDC		---
Input voltage range	0 VDC to supply voltage		
Input current range	3 to 6 mA/point	0.2 to 2 mA/point (input voltage: 5 to 24 VDC)	-1.1 to -0.5 mA/point (flowing out from terminals)
Minimum input time (see note 4)	B7A-T6C1: 16 ms; B7A-T6C6: 2.4 ms	B7A-T6D2: 16 ms; B7A-T6D7: 2.4 ms	2.4 ms
ON/OFF threshold	No-contact input: ON voltage: -4 V max. OFF voltage: -6 V min. Contact input: ON discrimination resistance: 660 Ω max. OFF discrimination resistance: 2 k Ω min.	ON voltage: 2.2 V min. OFF voltage: 0.8 V max.	ON voltage: 3 V max. OFF voltage: 6 V max.
Mounting strength	No damage when 49-N pull is applied for 1 min each in all directions (except in direction of DIN track)	---	---
Terminal strength	No damage when 49-N pull is applied each in all directions	---	---
Tightening torque	0.78 to 1.18 N • m	---	---
Weight	Approx. 160 g	Approx. 23 g	Approx. 25 g

- Note:**
1. If there is a possibility of noise interference from the power supply, input, and/or output lines, add appropriate noise protection circuits. Refer to *Noise Protection Circuits* on page 101 for details.
 2. A 3-wire NPN sensor with a residual voltage of 0.8 V maximum and a built-in collector load can be used. In this case, however, when the output transistor of the sensor is ON, the B7A will be OFF.
 3. Consumption when all 16 points are ON. Excludes external sensor current for Input Terminals.
 4. The minimum input time is required for the B7A to read an input signal.

Output Models

Item	Screw terminal models (100 mA/point)		
	B7A-R6B11/-R6B16/ -R6B31/-R6B36	B7AS-R6B11/-R6B16/ -R6B31/-R6B36	B7A-R6F11/-R6F16/ -R6F31/-R6F36
Output configuration	NPN open collector		PNP open collector
I/O delay time	B7A□-R6□□1: normal speed (typical 19.2 ms); B7A□-R6□□6: high speed (typical 3 ms)		
Error processing	B7A□-R6□□1: HOLD; B7A□-R6□□3: LOAD OFF		
Current consumption (see note)	80 mA max. with all output terminals ON	120 mA max. with all output terminals ON	80 mA max. with all output terminals ON
Power supply voltage	12 to 24 VDC		
Rated load voltage	5 to 24 VDC		
Output residual voltage	0.8 V max.		
Output current	Sync. current, 100 mA max./ point		Source current, 100 mA max./ point
Mounting strength	No damage when 49-N pull is applied for 1 min each in all directions (except in direction of DIN track)		
Terminal strength	No damage when 49-N pull is applied each in all directions (except in direction of DIN track)		
Tightening torque	0.78 to 1.18 N • m		
Weight	Approx. 160 g	Approx. 130 g	Approx. 160 g

Note: Consumption when all 16 points are ON. Excludes external load current and error load current for Output Terminals.

Item	Screw terminal models (500 mA/point)		Modular models	Compact modular models
	B7A-R6C11/-R6C16/ -R6C31/-R6C36	B7A-R6G11/-R6G16/ -R6G31/-R6G36	B7A-R6A52/-R6A57	B7A-R6A57-D
Output configuration	N-channel MOS-FET open drain (NPN compatible)	P-channel MOS-FET open drain (PNP compatible)	NPN open collector	
I/O delay time	B7A-R6□□1: normal speed (typical 19.2 ms); B7A-R6□□6: high speed (typical 3 ms)		B7A-R6A52: normal speed (typical 19.2 ms) B7A-R6A57: high speed (typical 3 ms)	---
Error processing	B7A-R6□1□: HOLD; B7A-R6□3□: LOAD OFF		HOLD (H/L terminals open) LOAD OFF (H/L terminals connected to 0 V)	
Current consumption (see note 1)	100 mA max. with all output terminals ON		40 mA max. with all output terminals ON	
Power supply voltage	12 to 24 VDC			---
Rated load voltage	5 to 24 VDC			
Output residual voltage	0.8 V max.			
Output current	Sync. current, 500 mA max./point (see note 2)	Source current, 500 mA max./point (see note 2)	Sync. current, 50 mA max./point	
Mounting strength	No damage when 49-N pull is applied for 1 min each in all directions (except in direction of DIN track)		---	---
Terminal strength	No damage when 49-N pull is applied each in all directions (except in direction of DIN track)		---	---
Tightening torque	0.78 to 1.18 N • m		---	---
Output logic	---		Active high (N/P terminals open) Active low (N/P terminals connected to 0 V) (see note 3)	Active low
Weight	Approx. 170 g		Approx. 23 g	Approx. 25 g

- Note:**
1. Consumption when all 16 points are ON. Excludes external load current and error load current for Output Terminals.
 2. If a single power supply is connected to the Input or Output Link Terminal via a VCTF cable with a thickness of 0.75 mm² minimum, the current flow must not exceed 1.8 A.
 3. Refer to *I/O Status* on page 102 for the relationship between the output logic and output ON/OFF status of the B7A.

Nomenclature

B7A

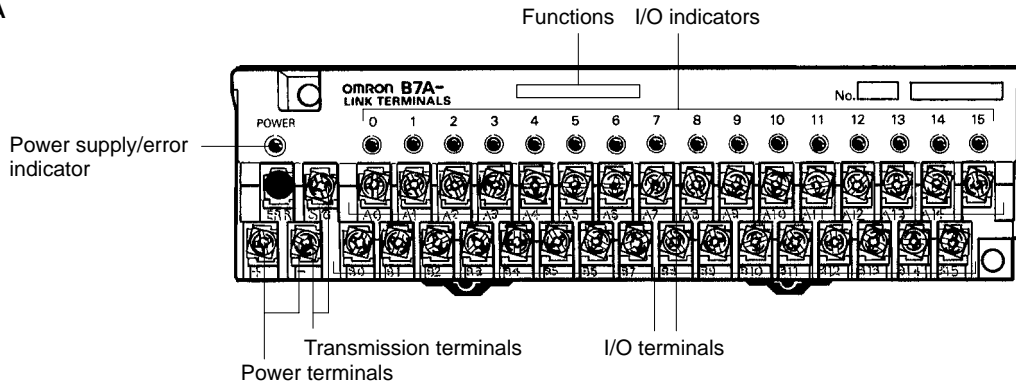

B7AS

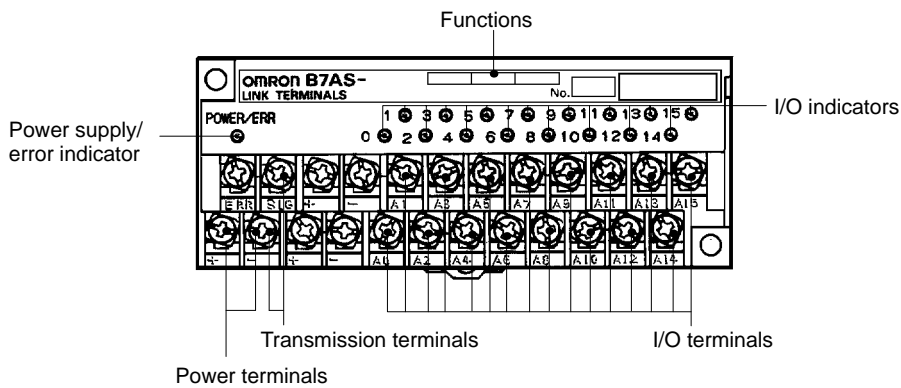

Indicator Operation

Indicator	Function
POWER (Input Terminal)	G Lit when power is supplied and the Terminal is operating.
	N Not lit when power is not supplied.
POWER/ERR (Output Terminal)	G Lit when power is supplied and the Terminal is operating without error.
	R Lit during transmission errors.
	N Not lit when power is not supplied.
I/O	O Lit when the input signals are ON.
	N Not lit when the signals are OFF.

Note: G: Green indicator lit; R: Red indicator lit; O: Orange indicator lit; N: Not lit

Recommended Solderless Terminals

Wire	JIS specifications
0.75 mm ² (AWG#18)	RAV 1.25 to 3.5 (vinyl-insulated round wire) or RAP 1.25 to 3.5
1.25 mm ² (AWG#16)	(nylon-insulated round wire)

Functions

I/O classification	Display	Description
Input		Input configuration Indicates the compatible transistor type for the input device.
		I/O delay time Indicates the typical I/O delay time of the B7A. Use a combination of an Input and an Output Link Terminal with the same I/O delay time.
Output		Output configuration Indicates the compatible transistor type for the output transistor.
		Output current Indicates the rated output current value of the B7A per point.
		I/O delay time Indicates the typical I/O delay time of the B7A. Use a combination of an Input and an Output Link Terminal with the same I/O delay time.

Operation

■ Power Supply

There are normal-speed and high-speed 16-point models, which are different in recommended transmission cable and transmission distance. If only a single power supply is connected to either the input model or output model, the current on the power line will be limited.

Screw Terminal Models

I/O Delay: Normal Speed

Connection of Independent Power Supplies

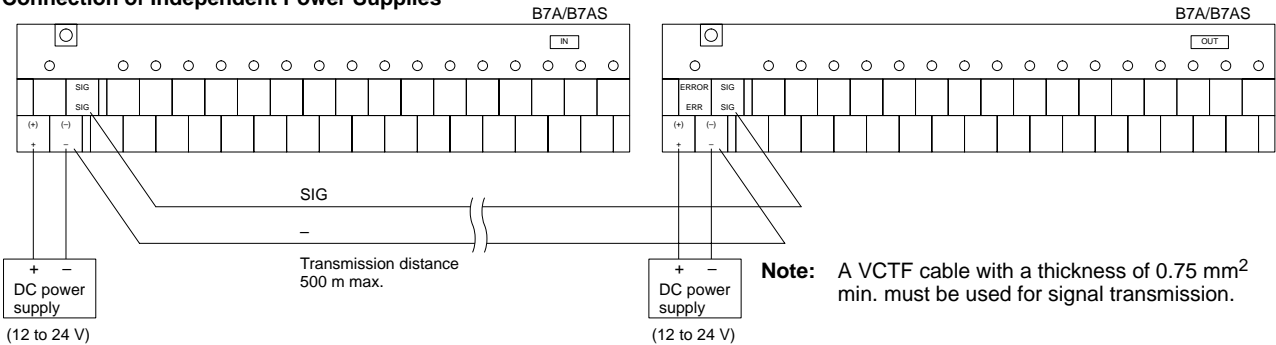

Connection of Single Power Supply to Input or Output Terminal

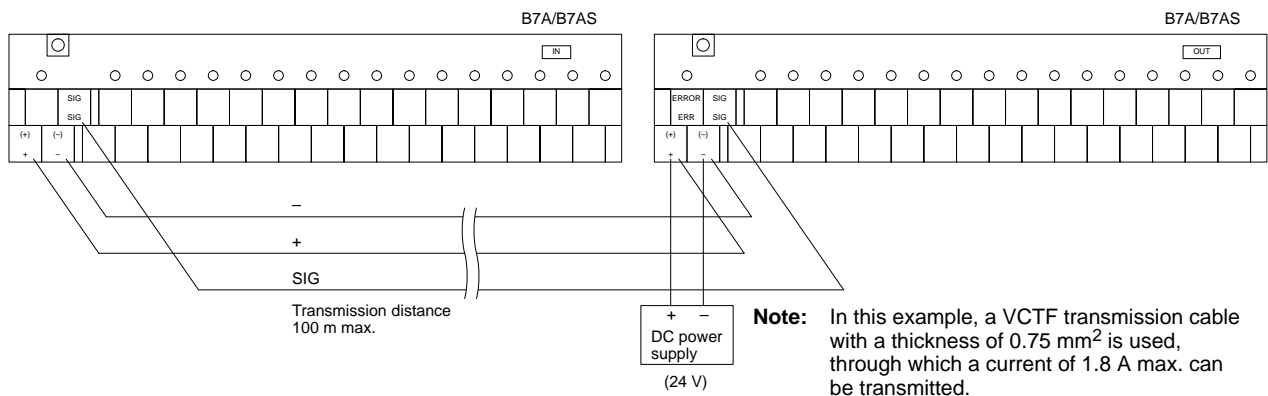

I/O Delay: High Speed

Connection of Independent Power Supplies

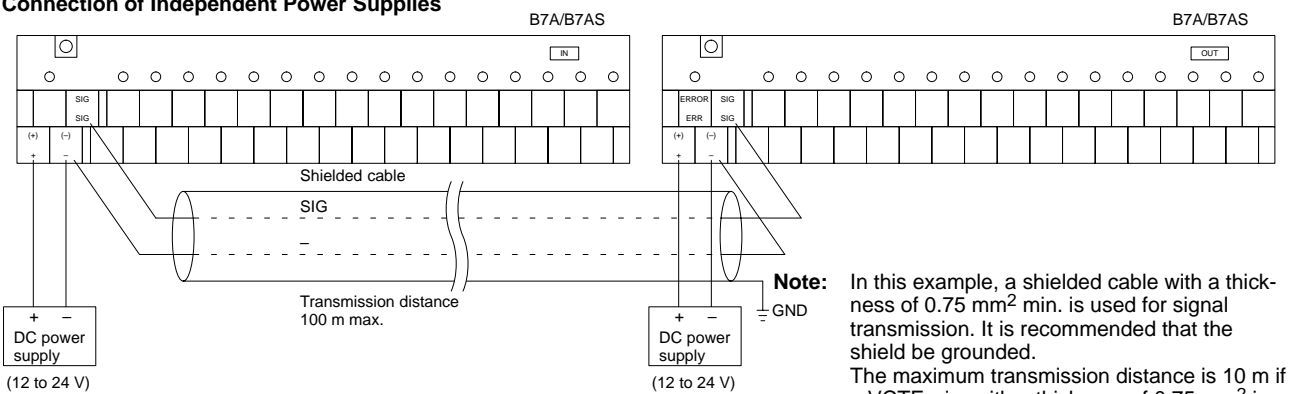

Connection of Single Power Supply to Input or Output Terminal

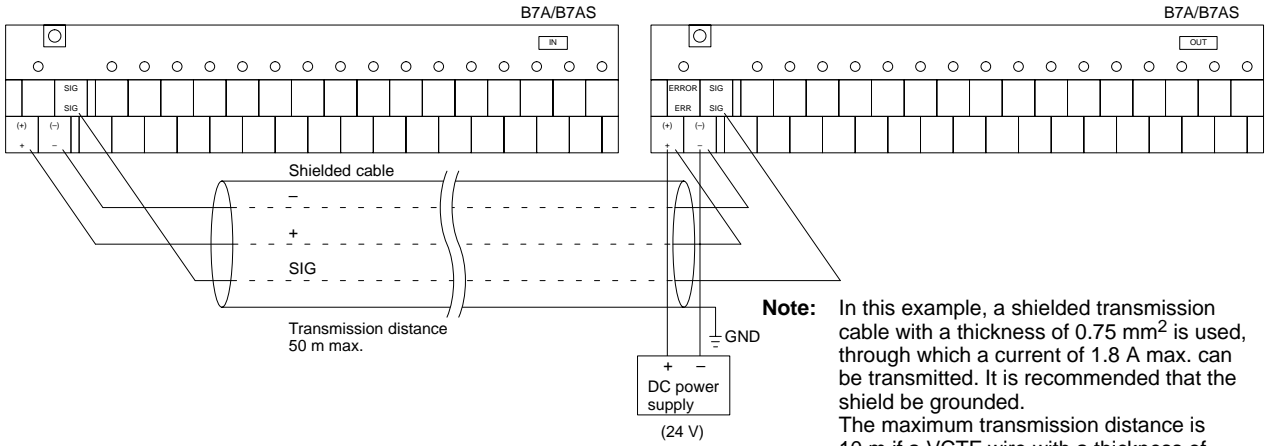

Note: In this example, a shielded transmission cable with a thickness of 0.75 mm² is used, through which a current of 1.8 A max. can be transmitted. It is recommended that the shield be grounded. The maximum transmission distance is 10 m if a VCTF wire with a thickness of 0.75 mm² is used instead of a shielded cable for the transmission path.

Modular Models

I/O Delay: Normal Speed

Connection of Independent Power Supplies

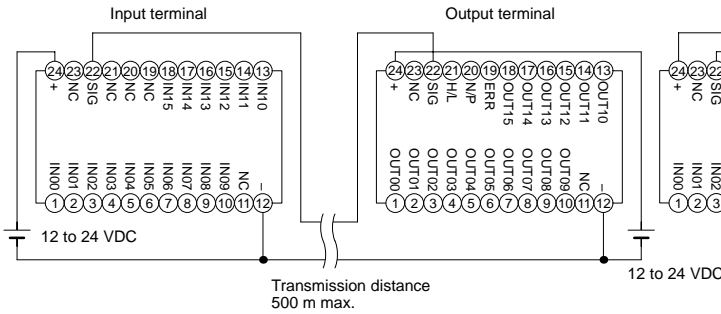

Note: A VCTF cable with a thickness of 0.75 mm² min. must be used for signal transmission.

Connection of Single Power Supply to Input or Output Terminal

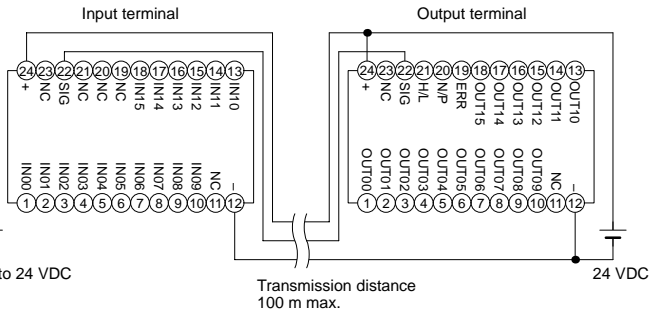

Note: In this example, a VCTF transmission cable with a thickness of 0.75 mm² min. is used, through which a current of 1.8 A max. can be transmitted.

I/O Delay: High Speed

Connection of Independent Power Supplies

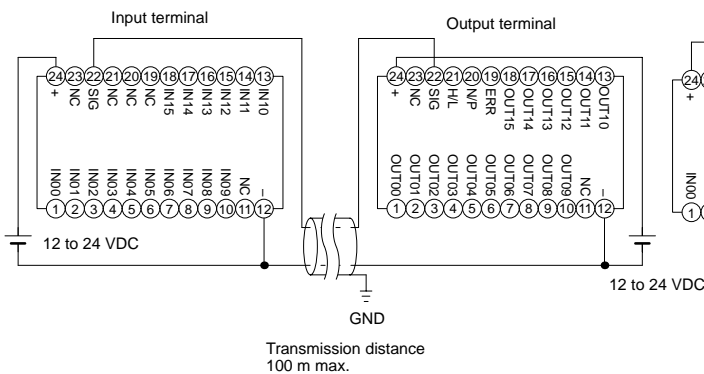

Note: A shielded cable with a thickness of 0.75 mm² min. must be used for signal transmission. It is recommended that the shield be grounded. The maximum transmission distance is 10 m if a VCTF wire with a thickness of 0.75 mm² is used instead of a shielded cable for the transmission path.

Connection of Single Power Supply to Input or Output Terminal

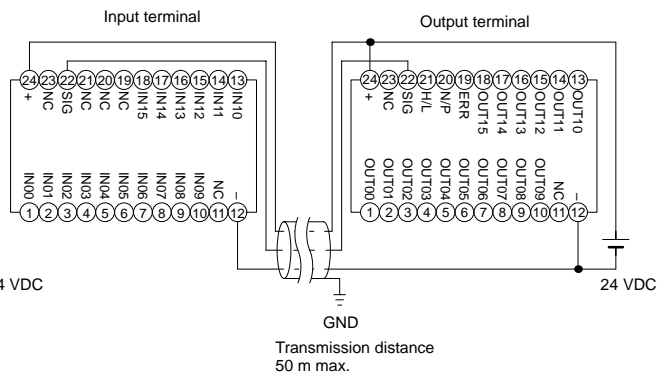

Note: In this example, a shielded transmission cable with a thickness of 0.75 mm² min. is used, through which a current of 1.8 A max. can be transmitted. It is recommended that the shield be grounded. The maximum transmission distance is 10 m if a VCTF wire with a thickness of 0.75 mm² is used instead of a shielded cable for the transmission path.

Dimensions

Note: All units are in millimeters unless otherwise indicated.

Screw Terminal Models

B7A

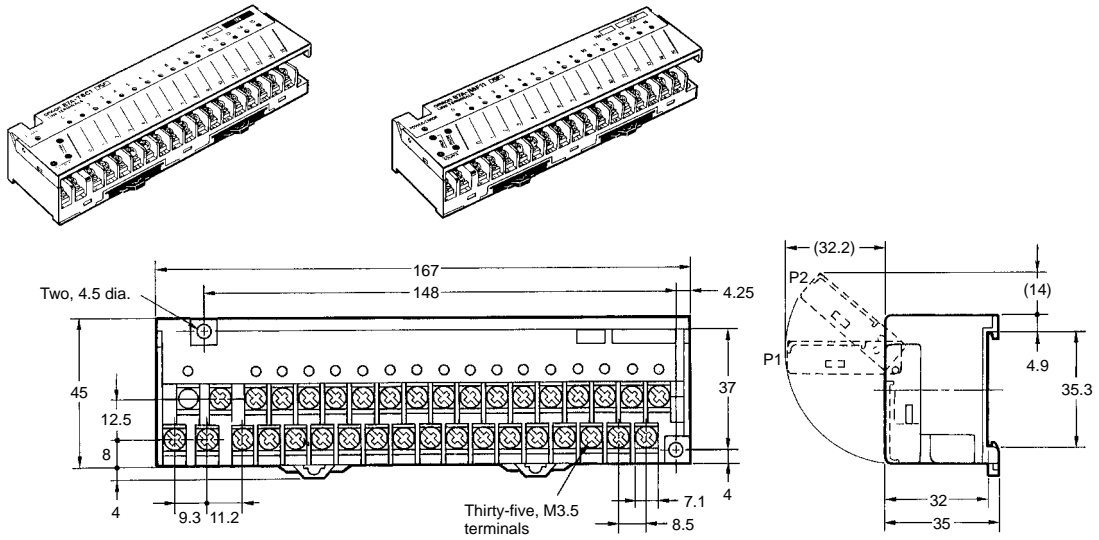

Compact Models

B7AS

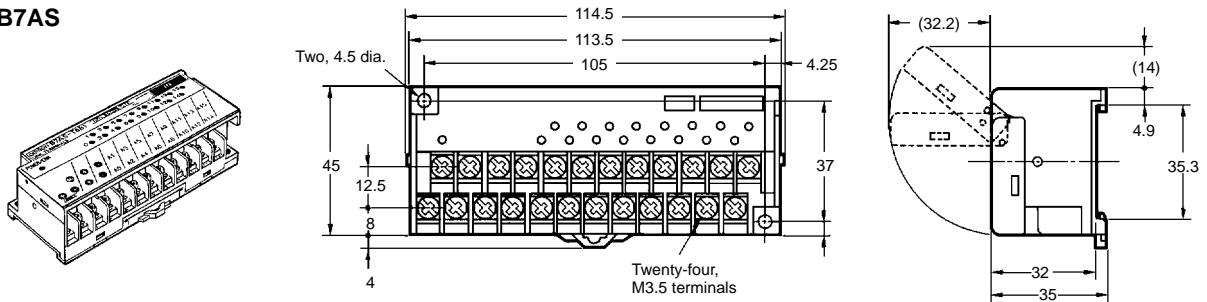

Modular Models

(B7A-T6D2, B7A-T6D7, B7A-R6A52, B7A-R6A57)

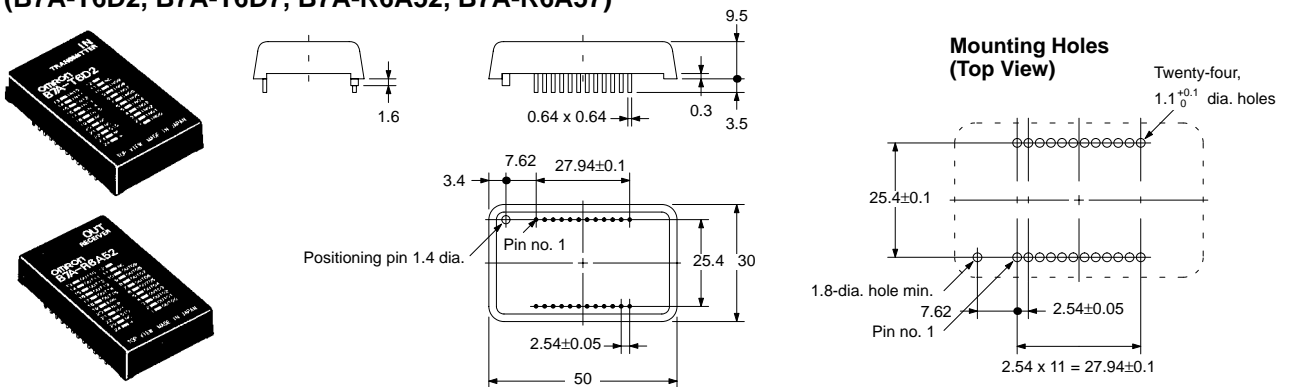

Compact Modular Models
(B7A-T6D7-D, B7A-R6A57-D)

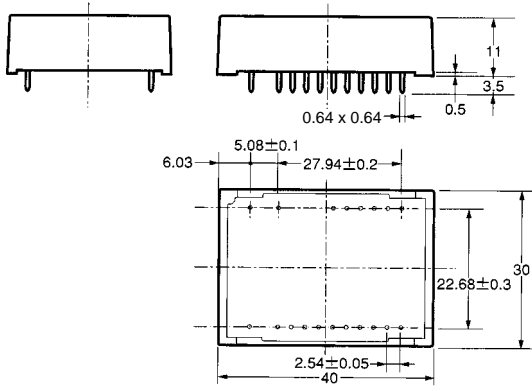

Mounting Holes
(Top View)

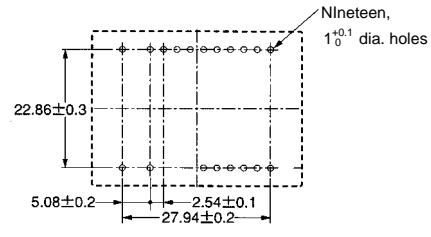

Installation

Internal Circuits and Terminal Arrangement

Screw Terminal Models

B7A-T6A1/-T6A6
(Input, Active Low)

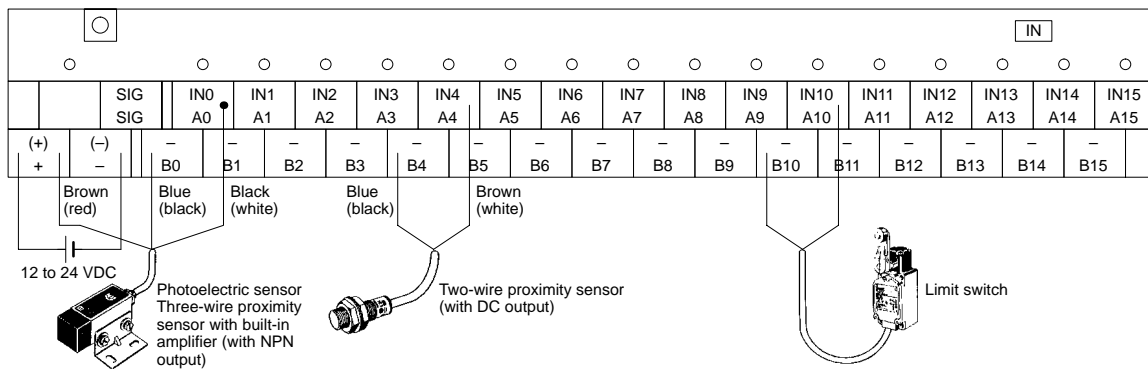
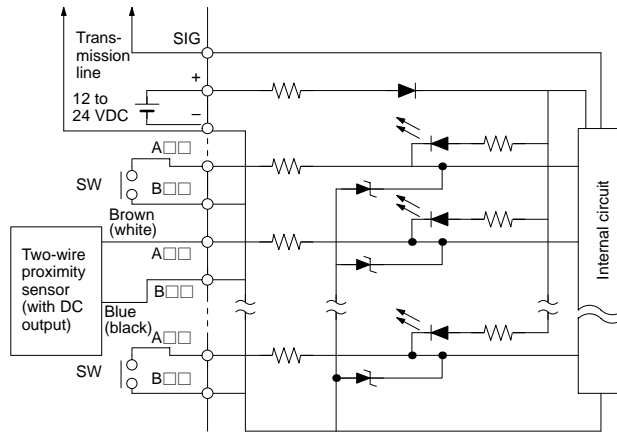

B7A-T6B1/-T6B6
(Input, Active Low)

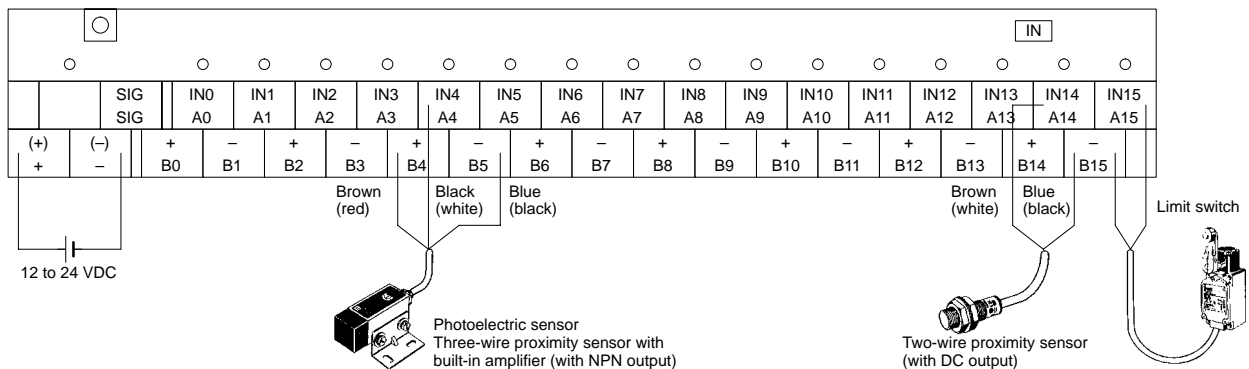
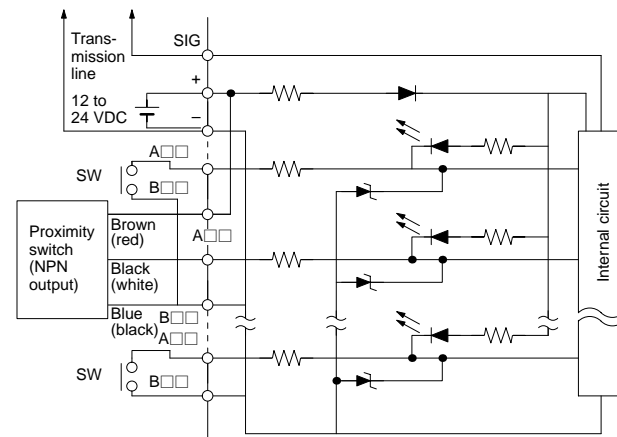

**B7AS-T6B1/-T6B6
(Input, Active Low)**

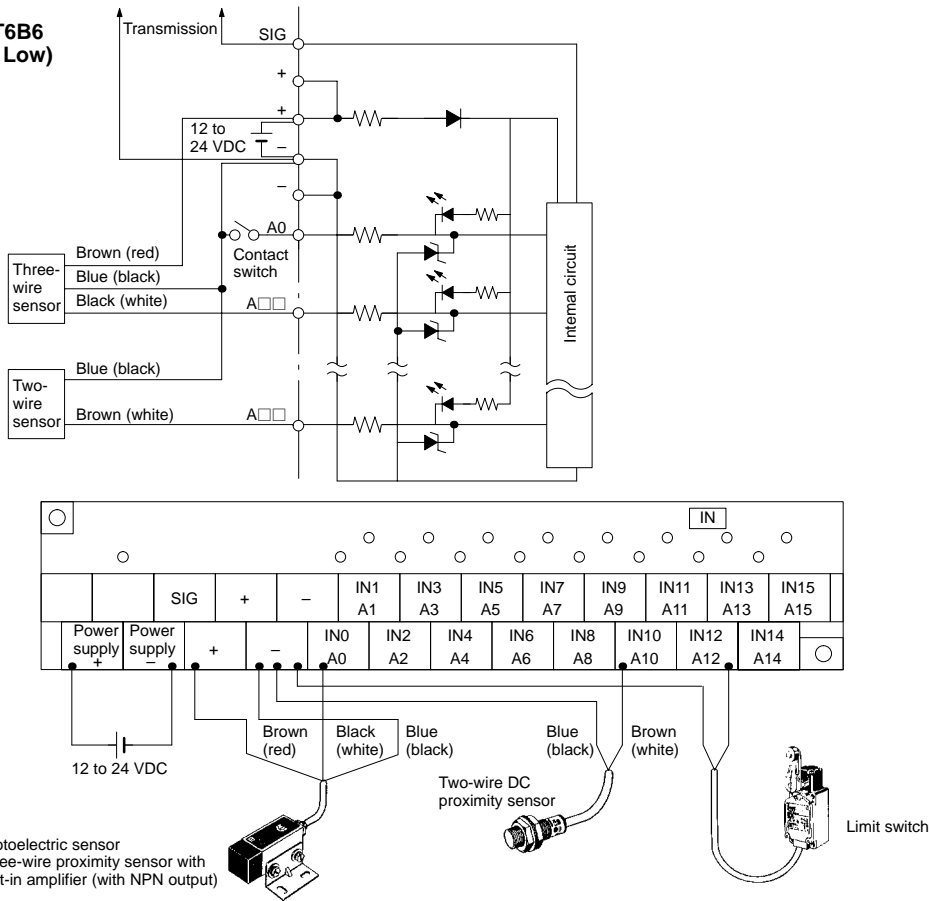

- Note:**
1. The wire colors have been changed in accordance with the revision of the Japanese Industrial Standards for photoelectric sensors and proximity sensors. The colors in parentheses refer to the old colors.
 2. Do not short-circuit the SIG terminal with the positive power supply terminal, negative power supply terminal, or a B□□ terminal, otherwise the internal elements of the B7A will be damaged and no transmission will be possible.

B7A-T6C1/-T6C6
(Input, Active High)

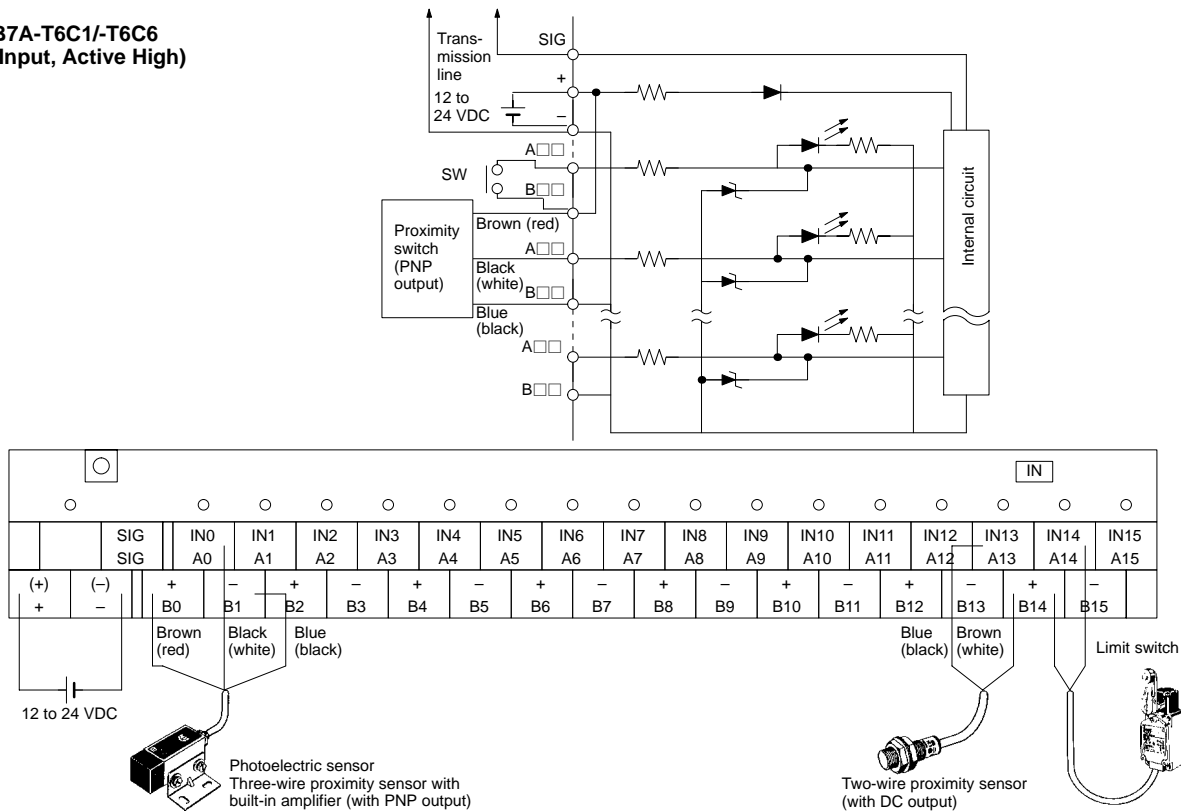

- Note:**
1. The wire colors have been changed in accordance with the revision of the Japanese Industrial Standards for photoelectric sensors and proximity sensors. The colors in parentheses refer to the old colors.
 2. Do not short-circuit the SIG terminal with the positive power supply terminal, negative power supply terminal, or a B□□ terminal, otherwise the internal elements of the B7A will be damaged and no transmission will be possible.

B7A-R6B11/-R6B16/-R6B31/-R6B36
(Output, NPN Open Collector)

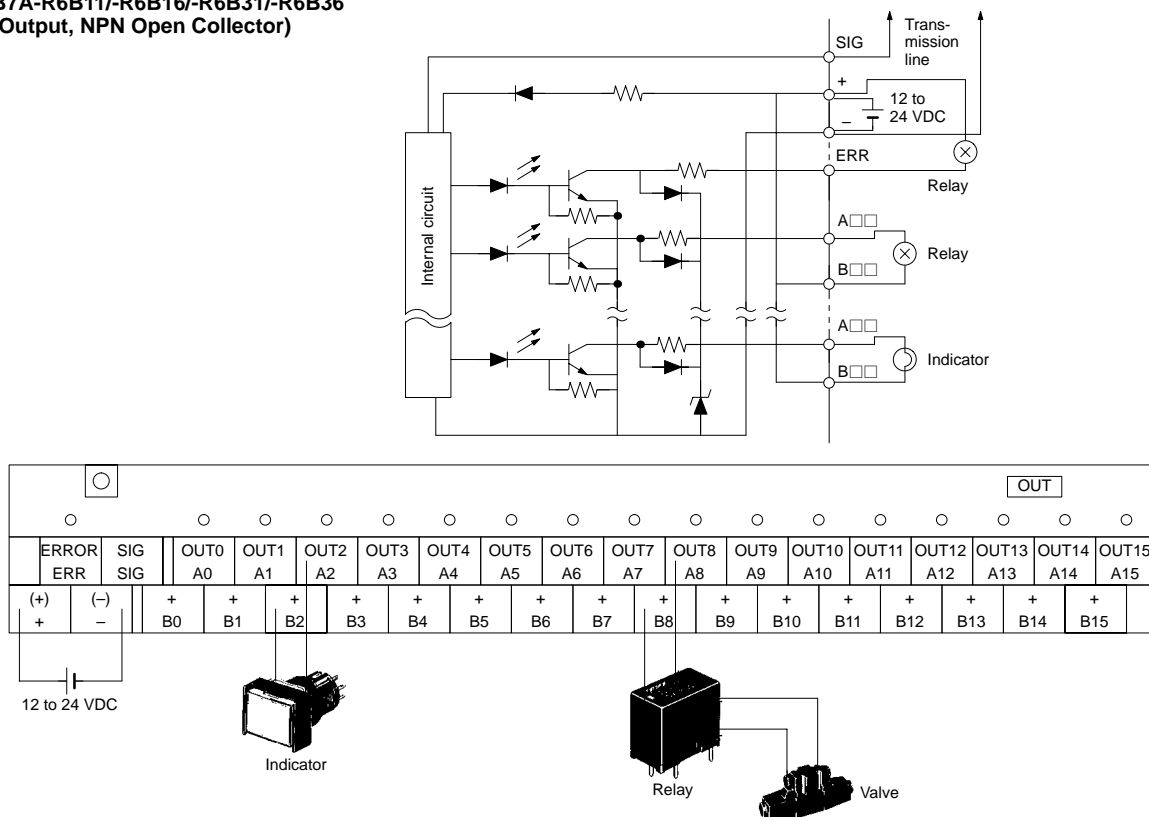

B7AS-R6B11/-R6B16/-R6B31/-R6B36
(Output, NPN Open Collector)

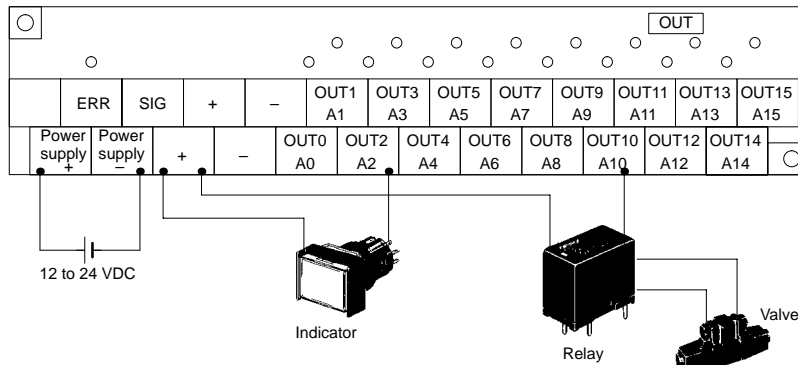
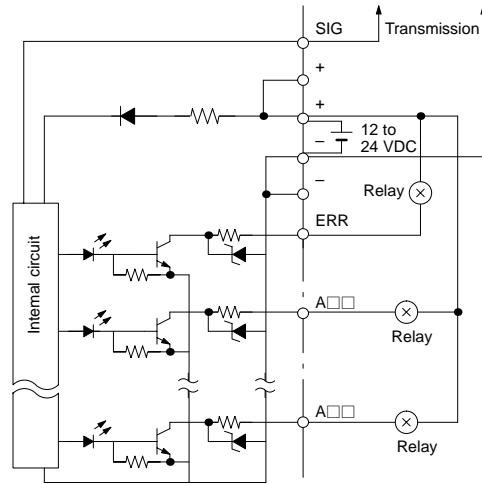

Note: Do not short-circuit terminals A□□ and B□□, otherwise the internal element(s) of the B7A may be damaged.

B7A-R6F11/-R6F16/-R6F31/-R6F36
(Output, PNP Open Collector)

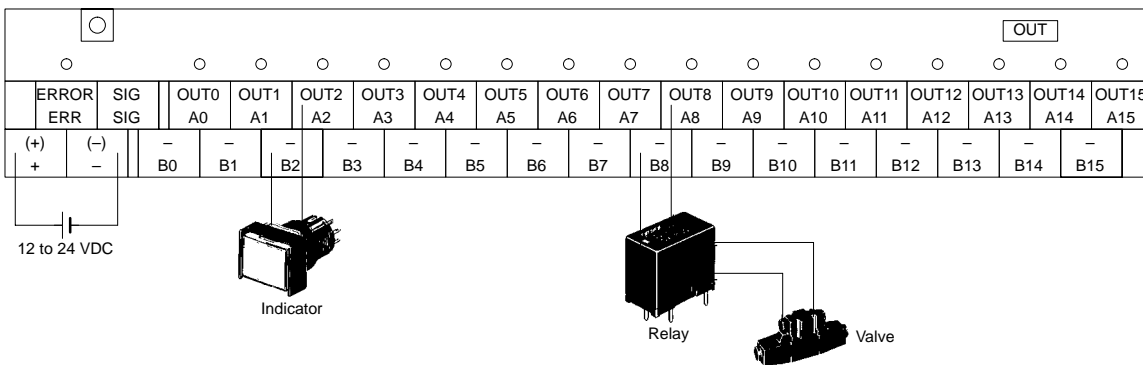
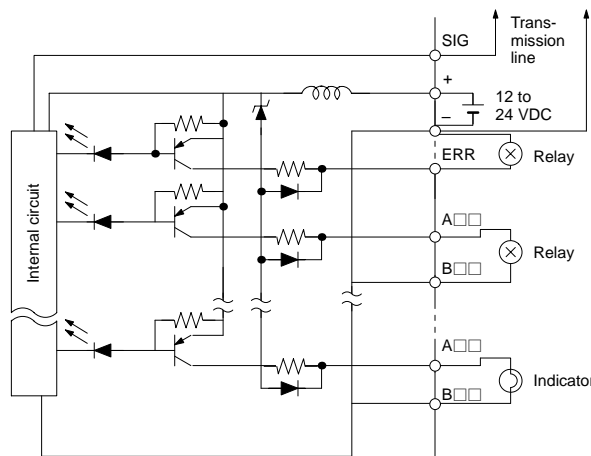

B7A-R6C11/R6C16/R6C31/R6C36
 (N-channel MOS-FET Open Drain Output,
 NPN Compatible)

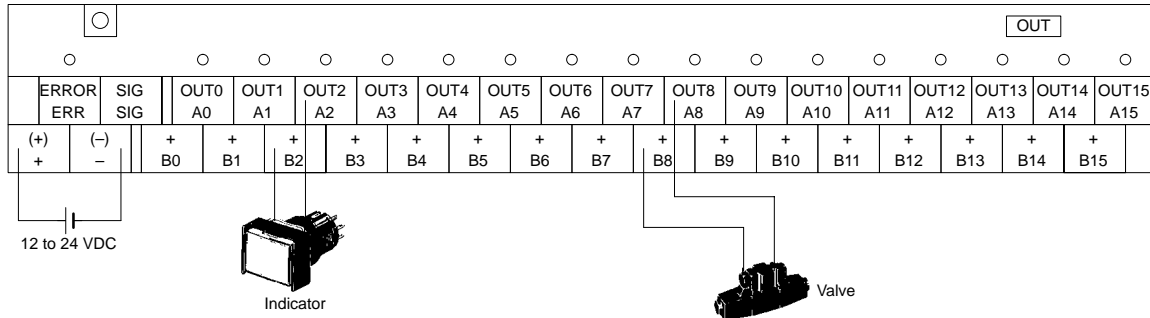
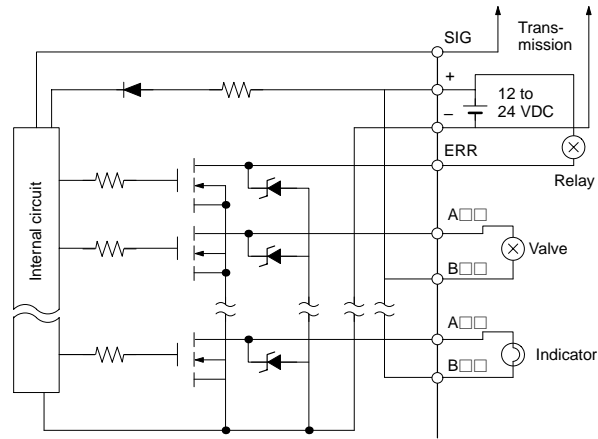

B7A-R6G11/R6G16/R6G31/R6G36
 (P-channel MOS-FET Open Drain Output,
 PNP Compatible)

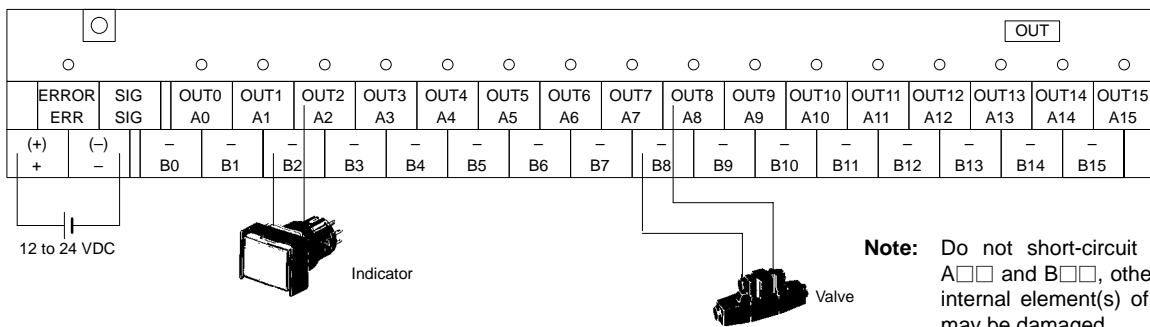
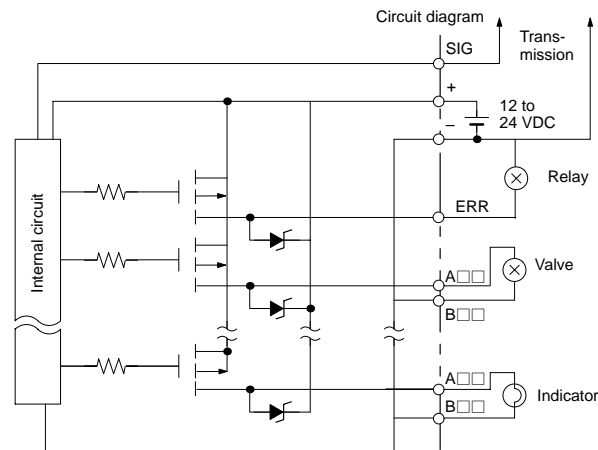

Note: Do not short-circuit terminals A□□ and B□□, otherwise the internal element(s) of the B7A may be damaged.

Modular Models

B7A-T6D2/-T6D7
(Input, Active High)

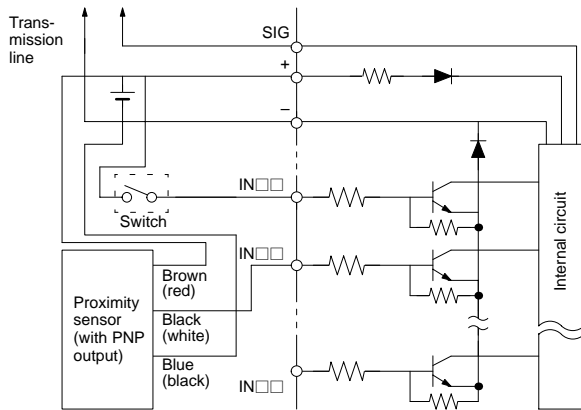

Top View

13 ■ IN10	12 ■ -
14 ■ IN11	11 ■ NC
15 ■ IN12	10 ■ IN09
16 ■ IN13	9 ■ IN08
17 ■ IN14	8 ■ IN07
18 ■ IN15	7 ■ IN06
19 ■ NC	6 ■ IN05
20 ■ NC	5 ■ IN04
21 ■ NC	4 ■ IN03
22 ■ SIG	3 ■ IN02
23 ■ NC	2 ■ IN01
24 ■ +	1 ■ IN00 ○

- Note:**
1. The wire colors have been changed in accordance with the revision of the Japanese Industrial Standards for photoelectric sensors and proximity sensors. The colors in parentheses refer to the old colors.
 2. Do not short-circuit the SIG terminal with a positive or negative power supply terminal, otherwise the internal elements of the B7A will be damaged and no transmission will be possible.

B7A-R6A52/-R6A57
(Output, NPN Open Collector)

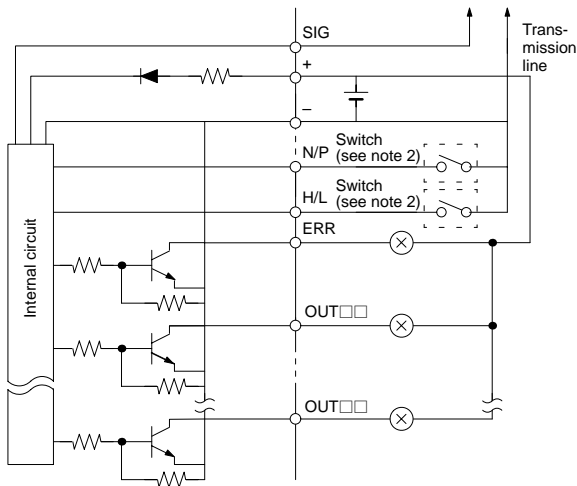

Top View

13 ■ OUT10	12 ■ -
14 ■ OUT11	11 ■ NC
15 ■ OUT12	10 ■ OUT09
16 ■ OUT13	9 ■ OUT08
17 ■ OUT14	8 ■ OUT07
18 ■ OUT15	7 ■ OUT06
19 ■ ERR	6 ■ OUT05
20 ■ N/P	5 ■ OUT04
21 ■ H/L	4 ■ OUT03
22 ■ SIG	3 ■ OUT02
23 ■ NC	2 ■ OUT01
24 ■ +	1 ■ OUT00 ○

- Note:**
1. Do not short-circuit any output terminal with the positive terminal, otherwise the internal elements of the B7A will be damaged.
 2. Logic output processing and error output processing methods can be selected with the selectors. The selectors are not required when the B7A is used with its output fixed to the output logic.

N/P: Negative/Positive		H/L: HOLD/LOAD OFF	
Terminal processing	Function	Terminal processing	Function
Open	Output logic active H	Open	Error output processing: HOLD
Connected to 0 V	Output logic active L	Connected to 0 V	Error output processing: LOAD OFF

Compact Modular Models

B7A-T6D7-D
(Input)

Circuit Diagram

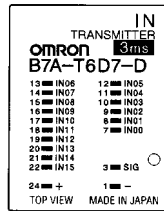
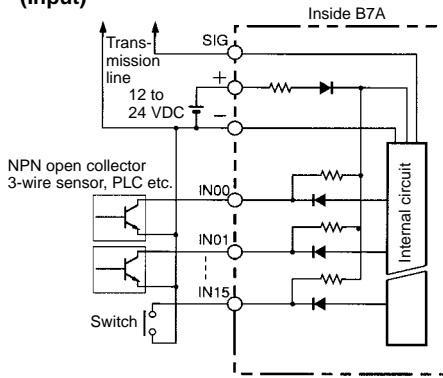

B7A-R6A57-D
(Output)

Circuit Diagram

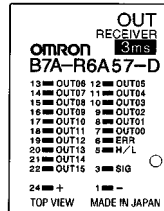
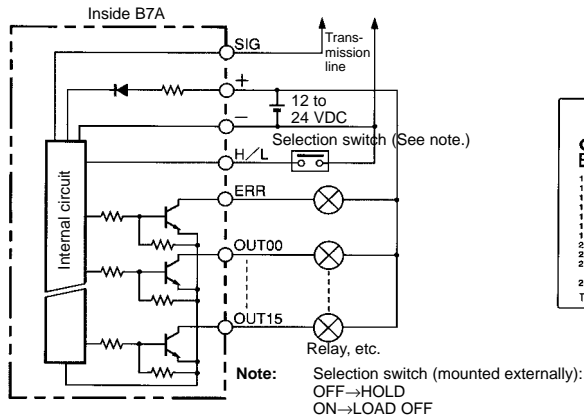

Transmit Signals while Saving Wiring Effort and Space between the B7A and PLC

- Connecting to an OMRON PLC and 16-point B7A with ease.
- Models with 16-point terminals and 32-point terminals are available.
- Transmit 16 input signals over just 2 wires (or over 3 wires if only one terminal has power supply) and 32 input signals over just 3 wires (or over 4 wires if only one terminal has power supply).



Ordering Information

■ Model Number Legend

Input Models

B7A - T E
 1 2 3 4

1. Input/Output Classification

T: Input

2. Number of I/O

6: 16
 3: 32

3. Input Configuration

E: NPN compatible

4. I/O Delay Time (Typical)

3: 19.2 ms
 8: 3 ms

Output Models

B7A - R A
 1 2 3 4 5

1. Input/Output Classification

R: Output

2. Number of I/O

6: 16
 3: 32

3. Output Configuration/ Capacity

A: NPN open collector/
 50 mA/point

4. Error Processing

1: HOLD
 3: LOAD OFF

5. I/O Delay Time (Typical)

3: 19.2 ms
 8: 3 ms

■ Product List

Refer to page 114 for details.

■ I/O Combinations

Refer to pages 1 to 5 for details.

Specifications

■ Characteristics

General

	Normal speed	High speed
Communications method	Unidirectional, time-division multiplex	
Transmission distance (see note 2)	500 m max.	100 m max. (see note 3)
I/O delay time	Typical: 19.2 ms; 31 ms max.	Typical: 3 ms; 5 ms max.
Minimum input time (see note 4)	16 ms (see note 5)	2.4 ms
Operating voltage range	12 to 24 VDC (10.8 to 26.4 VDC) (see note 2)	
Insulation resistance	100 MΩ min. (500 V) between each terminal and external parts	
Dielectric strength	1,000 VAC, 50/60 Hz for 1 min between each terminal and external parts	
Noise immunity (see note 6)	Noise level: 1.5 kV; pulse width: 100 ns to 1 μs (on transmission line due to coupling)	
Vibration resistance	10 to 55 Hz, 1.5-mm double amplitude	
Shock resistance	300 m/s ²	
Ambient temperature	Operating: -10 to 55°C (with no icing) Storage: -25 to 65°C (with no icing)	
Ambient humidity	Operating: 35% to 85% (with no condensation)	

- Note:**
1. If there is a possibility of noise interference from the power supply, input, and/or output lines, add appropriate noise protection circuits. Refer to *Noise Protection Circuits* on page 101 for details.
 2. The transmission distance values stated in this table are possible if the Input or Output Link Terminal is connected to an independent power supply. If a single power supply is connected to the Input or Output Link Terminal, the supply voltage must be 24 VDC ±10%, in which case the transmission distance of a normal-speed model is 100 m maximum and that of a high-speed model is 50 m maximum. Refer to *Power Supply* on page 36 for details.
 3. A shielded transmission cable or a VCTF cable with a thickness of 0.75 mm² minimum must be used for signal transmission. If the VCTF cable is used, however, the transmission distance will be 10 m maximum regardless of whether or not independent power supplies for the Input and the Output Link Terminals are used.
 4. The minimum input time is required for the B7A to read an input signal.
 5. Set the timer of the PLC to 0.02 s minimum if a normal-speed model is connected to the PLC.
 6. For high-speed models, these values are possible without grounding the shielded line.

Input Models

Item	16-point	32-point
	B7A-T6E3/T6E8	B7A-T3E3/T3E8
Compatible inputs	PLC (NPN output), switches, three-wire NPN sensors	
Input logic	Active low	
Current consumption (see note)	60 mA max. with all input terminals ON	100 mA max. with all input terminals ON
Input voltage range	0 VDC to supply voltage	
Input current range	-1.5 to -0.6 mA/point (current flowing from input terminals)	
ON/OFF threshold	No-contact input: ON voltage: 1.6 V max. OFF voltage: 5.5 V min. Contact input: ON discrimination resistance: 1 kΩ max. OFF discrimination resistance: 9 kΩ min.	
Mounting strength	No damage when 49-N pull is applied for 1 min each in all directions	
Terminal strength	No damage when 49-N pull is applied for 1 min each in all directions	
Tightening torque	0.78 to 1.18 N • m	
Weight	Approx. 46 g	Approx. 71 g

Note: Consumption when all 16/32 points are ON. Excludes external sensor current for Input Terminals.

Output Models

Item	16-point	32-point
	B7A-R6A13/R6A18/R6A33/R6A38	
		B7A-R3A13/R3A33/R3A18/R3A38
Output configuration	NPN open collector	
Current consumption (see note)	50 mA max. with all input terminals ON	80 mA max. with all input terminals ON
Rated load voltage	5 to 24 VDC	
Output residual voltage	0.8 V max.	
Output current	Sync. current, 50 mA max./point	
Error output	Rated load voltage: 0 to 30 VDC Output current: sync. current, 100 mA max./point	
Mounting strength	No damage when 49-N pull is applied for 1 min each in all directions	
Terminal strength	No damage when 49-N pull is applied for 1 min each in all directions	
Tightening torque	0.78 to 1.18 N • m	
Weight	Approx. 46 g	Approx. 71 g

Note: Consumption when all 16/32 points are ON. Excludes external load current and error load current for Output Terminals.

Nomenclature

16-point Terminal Models

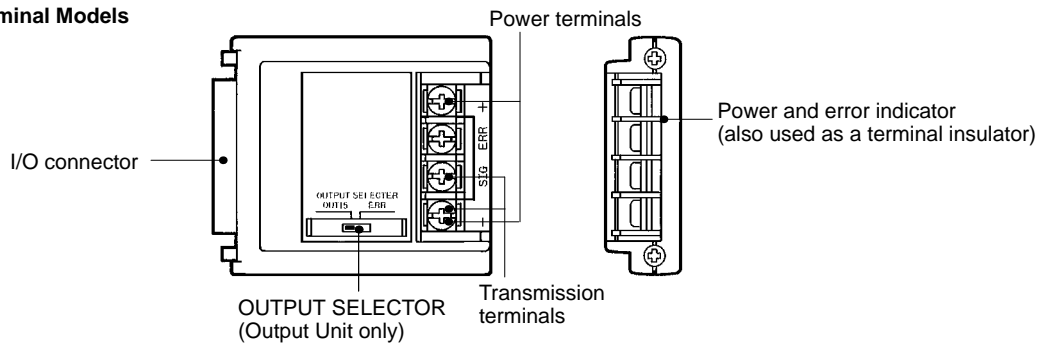

32-point Terminal Models

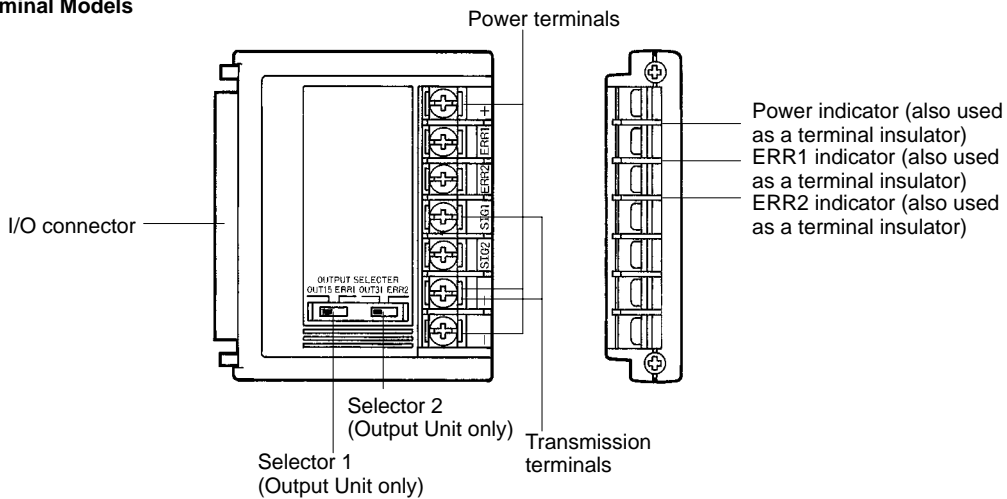

Indicator Operation

16-point Terminal Models

Indicator		Function
POWER (Input Terminal)	G	Lit when power is supplied and the Terminal is operating.
	N	Not lit when power is not supplied.
POWER/ERR (Output Terminal)	G	Lit when power is supplied and the Terminal is operating without error.
	R	Lit during transmission errors.
	N	Not lit when power is not supplied.

Note: G: Green indicator lit; R: Red indicator lit; N: Not lit

32-point Terminal Models

Indicator		Function
POWER (Input Terminal)	G	Lit when power is supplied and the Terminal is operating.
	N	Not lit when power is not supplied.
ERR1/ERR2 (Output Terminal)	N	Not lit when power is supplied and the Terminal is operating without error.
	R	Lit during transmission errors.
	N	Not lit when power is not supplied.

Note: G: Green indicator lit; R: Red indicator lit; N: Not lit

Recommended Solderless Terminals

Wire	JIS specifications
0.75 mm ² (AWG#18)	RAV 1.25 to 3.5 (vinyl-insulated round wire) or RAP 1.25 to 3.5
1.25 mm ² (AWG#16)	(nylon-insulated round wire)

Setting of Output Selector (Output Unit Only)

16-point Terminal Models

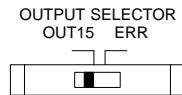

Switch	
OUT15	ERR
Set the 16th output to OUT15.	Set the 16th output to ERR (the ERR output is ON only when there is a transmission error).

32-point Terminal Models

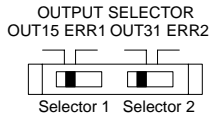

Switch 1		Switch 2	
OUT15	ERR1	OUT31	ERR2
Set the 16th output to OUT15.	Set the 16th output to ERR (the ERR output is ON only when there is a transmission error).	Set the 32nd output to OUT31.	Set the 32nd output to ERR (the ERR output is ON only when there is a transmission error).

Operation

■ Power Supply 16-point Terminal Models

I/O Delay: Normal Speed

Connection of Independent Power Supplies

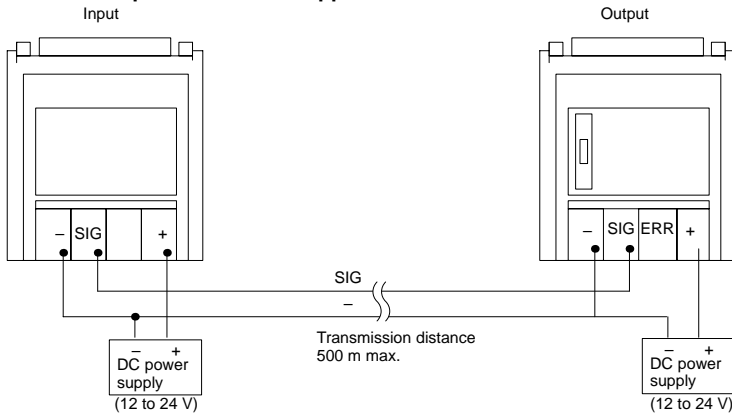

Note: A VCTF cable with a thickness of 0.75 mm² min. must be used for signal transmission.

Connection of Single Power Supply to Input or Output Terminal

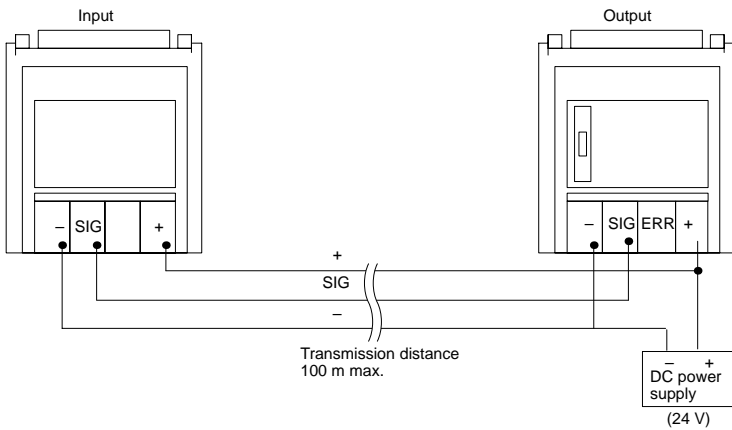

Note: In this example, a VCTF transmission cable with a thickness of 0.75 mm² min. is used, through which a current of 1.8 A max. can be transmitted.

I/O Delay: High Speed

Connection of Independent Power Supplies

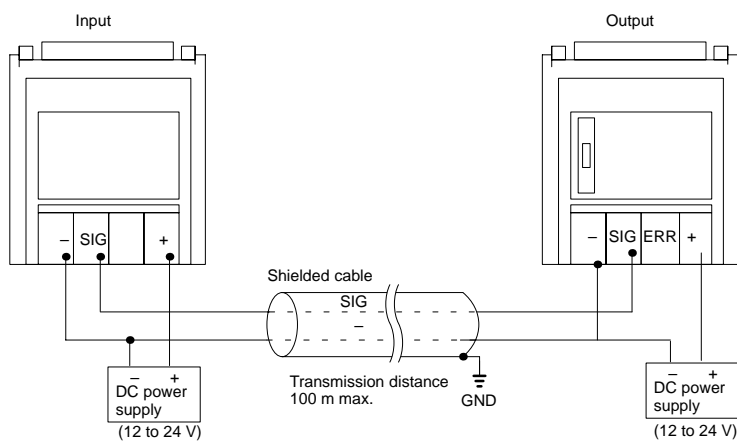

Note: A shielded cable with a thickness of 0.75 mm² min. must be used for signal transmission. It is recommended that the shield be grounded.

Connection of Single Power Supply to Input or Output Terminal

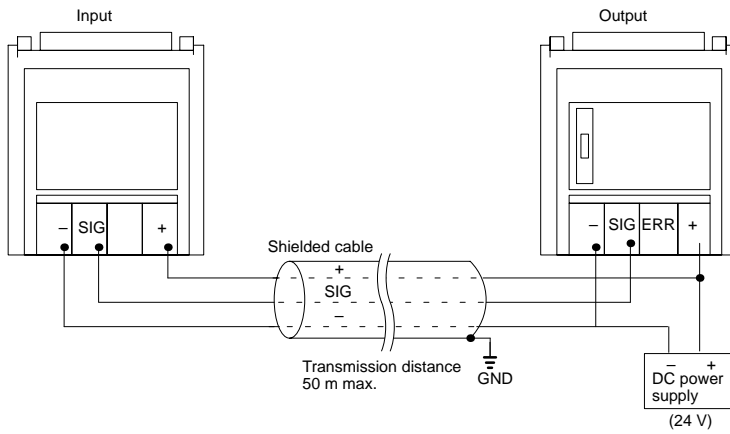

Note: In this example, a shielded transmission cable with a thickness of 0.75 mm² min. is used, through which a current of 1.8 A max. can be transmitted. It is recommended that the shield be grounded.

32-point Terminal Models

I/O Delay: Normal Speed

Connection of Independent Power Supplies

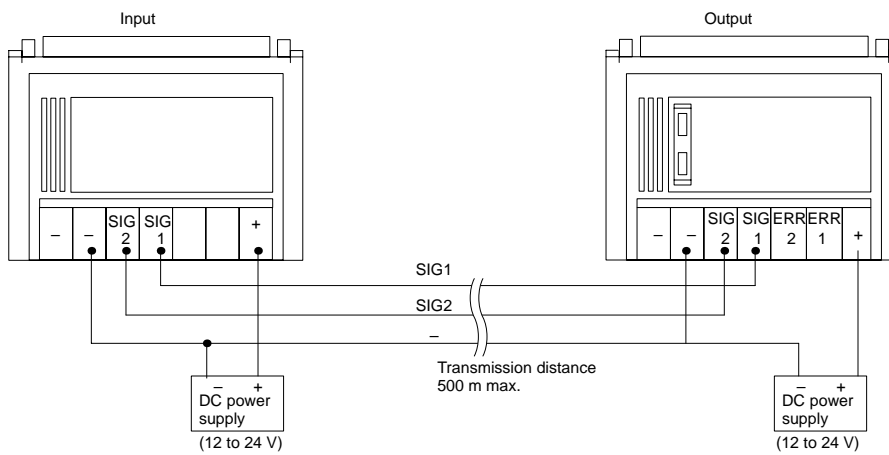

Note: A VCTF cable with a thickness of 0.75 mm² min. must be used for signal transmission.

Connection of Single Power Supply to Input or Output Terminal

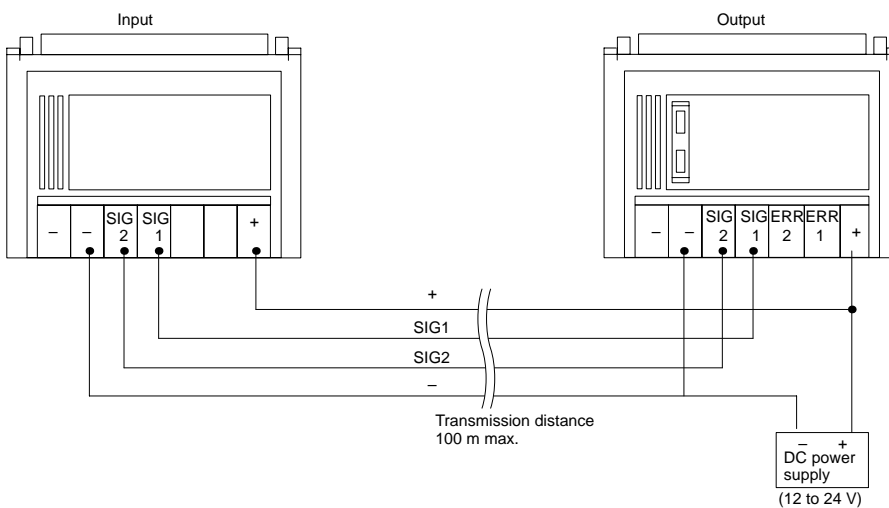

Note: In this example, a VCTF transmission cable with a thickness of 0.75 mm² min. is used, through which a current of 1.8 A max. can be transmitted.

I/O Delay: High Speed

Connection of Independent Power Supplies

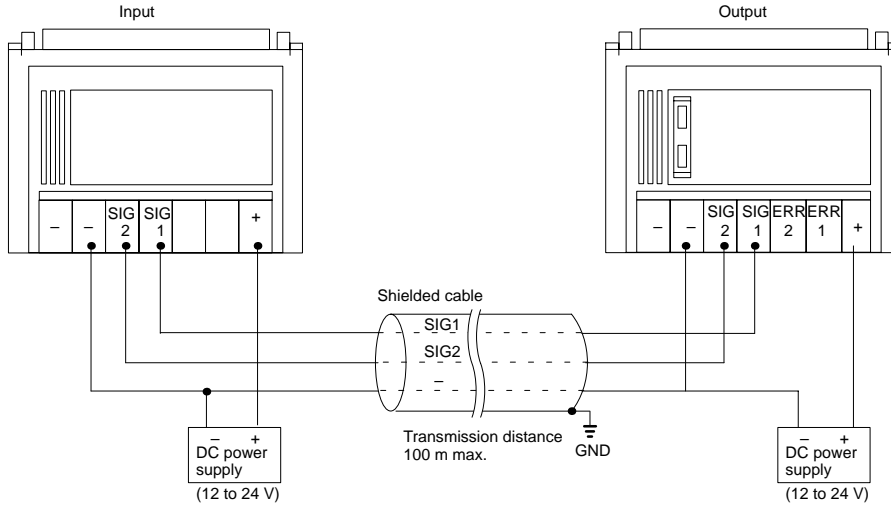

Note: A shielded cable with a thickness of 0.75 mm² min. must be used for signal transmission. It is recommended that the shield be grounded.

Connection of Single Power Supply to Input or Output Terminal

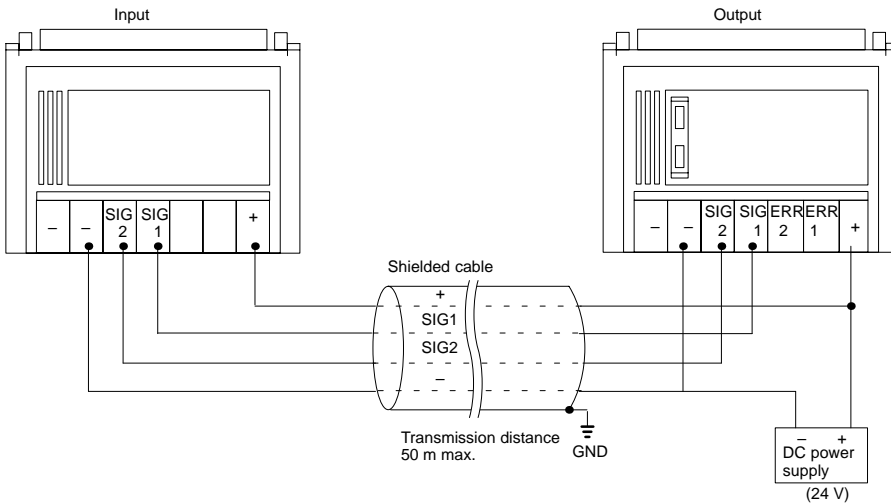

Note: In this example, a shielded transmission cable with a thickness of 0.75 mm² min. is used, through which a current of 1.8 A max. can be transmitted. It is recommended that the shield be grounded.

■ B7A-series Models with PLC Connectors and Connecting PLCs

Input

Model	I/O points	I/O delay	Input configuration	C200H					C500			CQM1
				MD115	MD215	OD215	OD218	OD219	MD211CN	OD415CN	OD213	OD213
B7A-T6E3	16	Normal speed	NPN compatible	Yes	Yes	Yes	---	---	Yes	Yes	---	---
B7A-T6E8		High speed		Yes	Yes	Yes	---	---	Yes	Yes	---	---
B7A-T3E3	32	Normal speed		---	---	---	Yes	Yes	---	---	Yes	Yes
B7A-T3E8		High speed		---	---	---	Yes	Yes	---	---	Yes	Yes

Output

Model	I/O points	I/O delay	Error processing	C200H					C500			CQM1	
				MD115	MD215	ID215	ID216	ID217	ID218CN	MD211CN	ID114	ID219	ID213
B7A-R6A13	16	Normal speed	HOLD	Yes	Yes	Yes	---	---	Yes	Yes	---	---	---
B7A-R6A33			LOAD OFF	Yes	Yes	Yes	---	---	Yes	Yes	---	---	---
B7A-R6A18		High speed	HOLD	Yes	Yes	Yes	---	---	Yes	Yes	---	---	---
B7A-R6A38			LOAD OFF	Yes	Yes	Yes	---	---	Yes	Yes	---	---	---
B7A-R3A13	32	Normal speed	HOLD	---	---	---	Yes	Yes	---	---	Yes	Yes	Yes
B7A-R3A33			LOAD OFF	---	---	---	Yes	Yes	---	---	Yes	Yes	Yes
B7A-R3A18		High speed	HOLD	---	---	---	Yes	Yes	---	---	Yes	Yes	Yes
B7A-R3A38			LOAD OFF	---	---	---	Yes	Yes	---	---	Yes	Yes	Yes

Connection with PLC

- Connect the B7A Output Unit incorporating a connector to the Input Unit for the PLC.
- Connect the B7A Input Unit incorporating a connector to the Output Unit for the PLC.

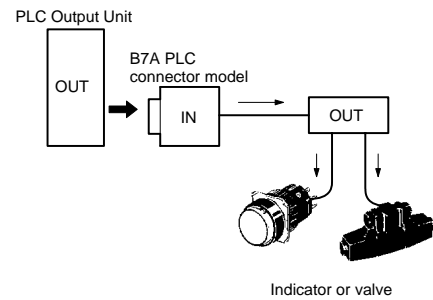
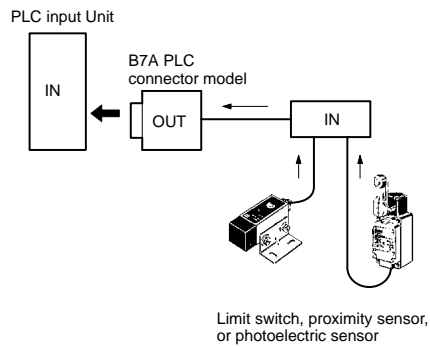

Dimensions

Note: All units are in millimeters unless otherwise indicated.

16-point Terminal Models

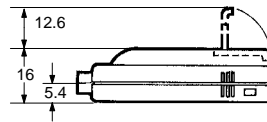
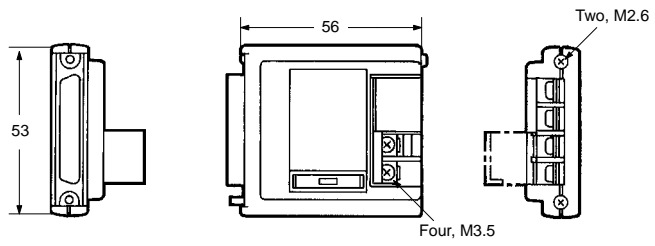
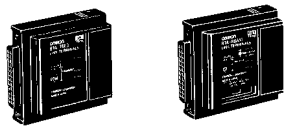

32-point Terminal Models

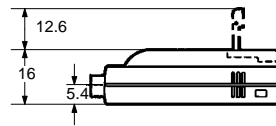
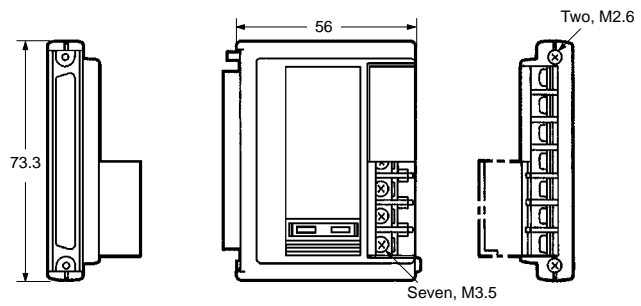
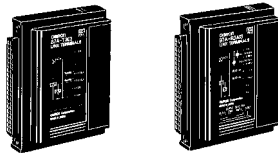

Installation

Internal Circuits and Terminal Arrangement

16-point Terminals

B7A-T6E3/-T6E8 (Input, Active Low)

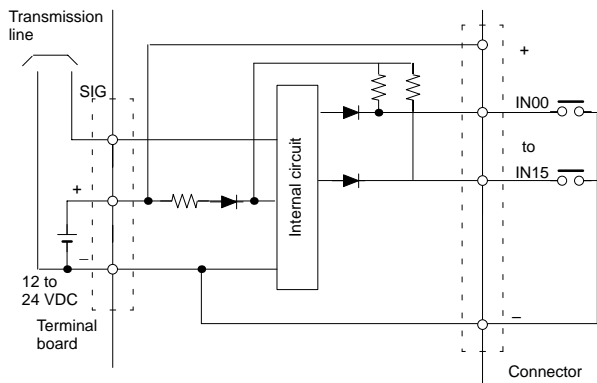

Terminal No.	Terminal	Terminal No.	Terminal
1	IN00	13	IN08
2	IN01	14	IN09
3	IN02	15	IN10
4	IN03	16	IN11
5	IN04	17	IN12
6	IN05	18	IN13
7	IN06	19	IN14
8	IN07	20	IN15
9	-	21	-
10	+	22	+
11	NC (open)	23	NC (open)
12	NC (open)	24	NC (open)

Note: Do not short-circuit the SIG terminal with a positive or negative power supply terminal, otherwise the internal elements of the B7A will be damaged and no transmission will be possible.

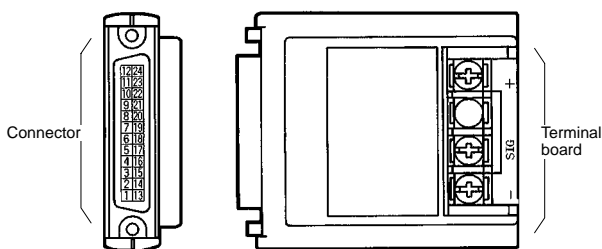

B7A-R6A13/-R6A18/-R6A33/-R6A38 (Output, NPN Open Collector)

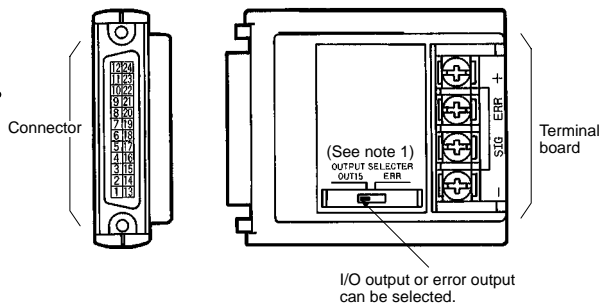
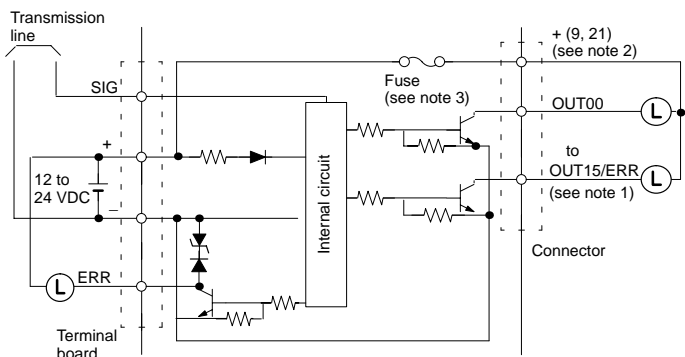

Terminal No.	Terminal	Terminal No.	Terminal
1	OUT00	13	OUT08
2	OUT01	14	OUT09
3	OUT02	15	OUT10
4	OUT03	16	OUT11
5	OUT04	17	OUT12
6	OUT05	18	OUT13
7	OUT06	19	OUT14
8	OUT07	20	OUT15/ERR (see note 1)
9	+ (see note 2)	21	+ (see note 2)
10	NC (open)	22	NC (open)
11	NC (open)	23	NC (open)
12	NC (open)	24	NC (open)

Note:

1. It is possible to select 16 I/O points or 15 I/O points and 1 error output point.
2. A maximum of 0.4 A can be supplied from each positive terminal.
3. The user cannot replace the fuse.
4. Do not short-circuit any output terminal with the positive terminal, otherwise the internal elements of the B7A will be damaged.

32-point Terminals

B7A-T3E3/T3E8 (Input, Active Low)

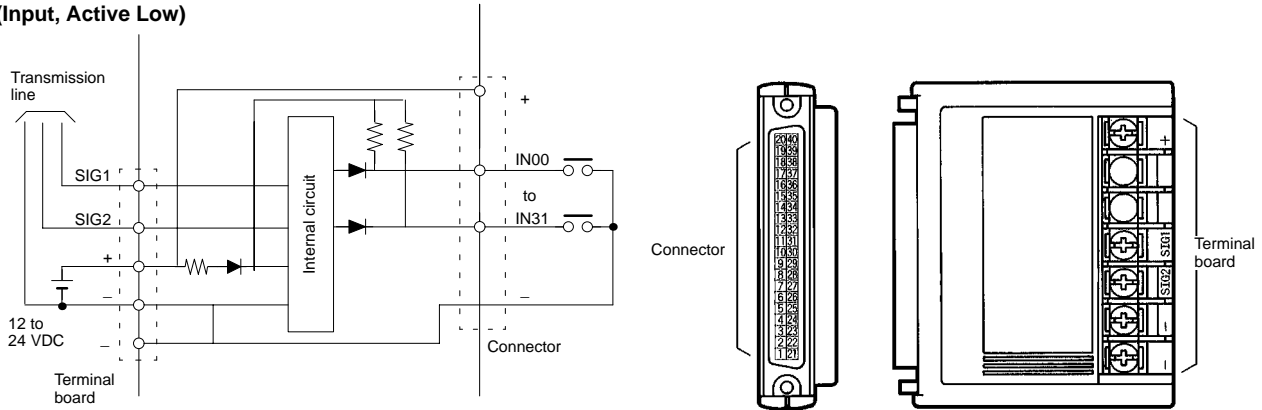

- SIG1: IN00 to IN15
- SIG2: IN16 to IN31

Terminal No.	Terminal	Terminal No.	Terminal	Terminal No.	Terminal
1	IN00	15	IN12	29	-
2	IN01	16	IN13	30	+
3	IN02	17	IN14	31	IN24
4	IN03	18	IN15	32	IN25
5	IN04	19	-	33	IN26
6	IN05	20	+	34	IN27
7	IN06	21	IN16	35	IN28
8	IN07	22	IN17	36	IN29
9	-	23	IN18	37	IN30
10	+	24	IN19	38	IN31
11	IN08	25	IN20	39	-
12	IN09	26	IN21	40	+
13	IN10	27	IN22		
14	IN11	28	IN23		

Note: Do not short-circuit the SIG terminal with a positive or negative power supply terminal, otherwise the internal elements of the B7A will be damaged and no transmission will be possible.

B7A-R3A13/R3A33/R3A18/R3A38
(Output, NPN Open Collector)

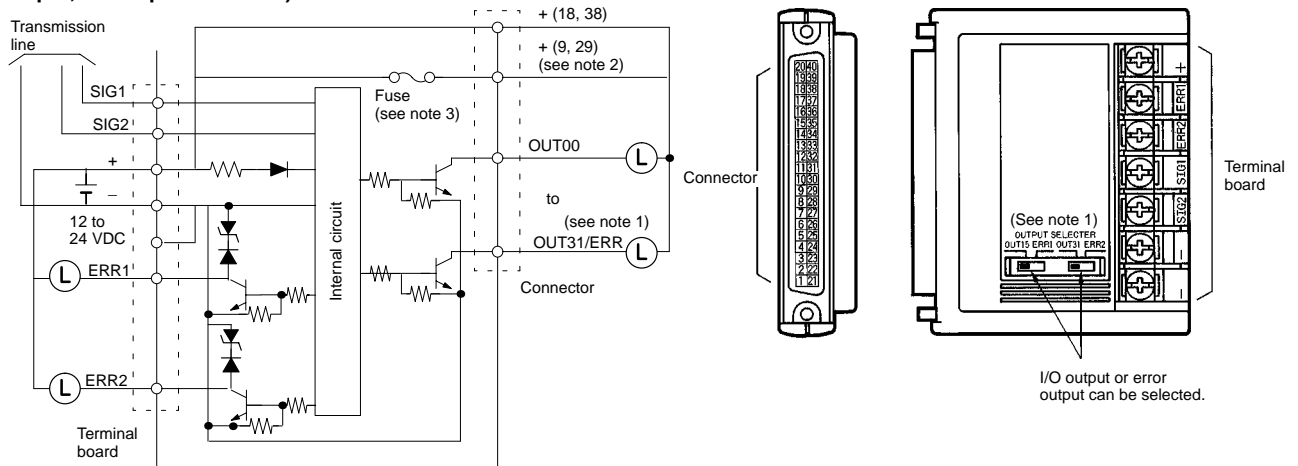

- SIG1: OUT00 to OUT15
- SIG2: OUT16 to OUT31

Terminal No.	Terminal	Terminal No.	Terminal	Terminal No.	Terminal
1	OUT00	15	OUT13	29	+ (see note 2)
2	OUT01	16	OUT14	30	OUT24
3	OUT02	17	OUT15/ERR (see note 1)	31	OUT25
4	OUT03	18	+	32	OUT26
5	OUT04	19	NC (open)	33	OUT27
6	OUT05	20	NC (open)	34	OUT28
7	OUT06	21	OUT16	35	OUT29
8	OUT07	22	OUT17	36	OUT30
9	+ (see note 2)	23	OUT18	37	OUT31/ERR (see note 1)
10	OUT08	24	OUT19	38	+
11	OUT09	25	OUT20	39	NC (open)
12	OUT10	26	OUT21	40	NC (open)
13	OUT11	27	OUT22		
14	OUT12	28	OUT23		

- Note:**
1. It is possible to select 32 output points or 30 output points and two error output points.
 2. A maximum of 0.4 A can be supplied from each positive terminal (9, 29).
 3. The user cannot replace the fuse.
 4. Do not short-circuit any output terminal with the positive terminal, otherwise the internal elements of the B7A will be damaged.

Ultra Miniature Link Terminal with B7A Communications Functions and 16 Output Points

- Equipped with B7A communications functions and enables wiring reductions in B7A connections (except for high-speed models).
- Power relay (G6D) models and power MOS FET relay (G3DZ) models available.
- Compact dimensions: 156 × 51 × 51 mm (W × D × H).
- The load is connected directly to the terminal block without the need for a relay terminal.
- Signal status can be confirmed at a glance with operation indicators.
- Incorporates surge absorbing diode.
- Equipped with Relay Removal Tool.
- Supports either screw mounting or DIN track mounting.



Ordering Information

■ Product List

Classification	Number of I/O points	Rated voltage	I/O delay time	Error processing	Model
Relay output	16 (SPST-NO × 16)	24 VDC	Normal (typical: 19.2 ms) (See note 1.)	HOLD (See note 2.)	G70D-R6R11-B7A
				LOAD OFF (See note 3.)	G70D-R6R31-B7A
Power MOS FET relay output				HOLD (See note 2.)	G70D-R6M11-B7A
				LOAD OFF (See note 3.)	G70D-R6M31-B7A

- Note:**
1. Not connectable to high-speed B7A models.
 2. When an error occurs, the status of outputs just before the error occurred is maintained.
 3. When an error occurs, all the outputs are turned OFF.

Specifications

■ Characteristics

Communications Specifications

Communications method	Unidirectional, time-division multiplex
Transmission distance (see note)	500 m max.
I/O delay time	Typical: 19.2 ms; 31 ms max.

- Note:** Separate power supplies are required for inputs and outputs.

General

G70D-R6R□1-B7A (Relay Outputs)

Item		Specification
Contacts		16 SPST-NO contacts
Contact mechanism		Single
Contact material		Agco
Contact resistance (See note 1.)		100 mΩ max.
Operating time		10 ms max.
Release time		10 ms max.
Maximum switching frequency	Mechanical	18,000 operations/hour
	Rated load	1,800 operations/hour
Insulation resistance		100 MΩ min. (500 V)
Dielectric strength		1,000 VAC, 1 min between each terminal and external parts
Noise immunity		Power supply normal: 600 V, 10 min; pulse width: 100 ns to 1 μs Power supply common: 1.5 kV, 10 min; pulse width: 100 ns to 1 μs Transmission path wrapping: 1.5 kV, 10 min; pulse width: 100 ns to 1 μs Link Terminal wrapping: 600 V, 10 min; pulse width: 100 ns to 1 μs
Vibration resistance	Destruction	10 to 55 Hz, 1.0-mm double amplitude for 2 hours each in X, Y, and Z directions
	Malfunction	10 to 55 Hz, 0.75-mm double amplitude for 2 hours each in X, Y, and Z directions
Shock resistance	Destruction	300 m/s ²
	Malfunction	100 m/s ²
Operating voltage range		24 VDC +10%/−15%
Current consumption (See note 2.)		24 VDC, approx. 300 mA
Cable length (between Unit and connected device)		Depends on the load
Color of indicators		Operation indicator: orange Power supply indicator: green (red for errors)
Coil surge suppressor		Diode (400 V, 300 mA)
Ambient temperature		Operating: 0 to 55°C Storage: −20 to 65°C
Ambient humidity		Operating: 35% to 85%
Mounting strength		No damage when 49-N pull is applied for 1 s each in all directions (only 9.8-N pull in direction of DIN track)
Terminal strength		Tightening strength: 0.78 to 0.98 N·m Tensile strength: 49 N for 1 minute
Weight		Approx. 230 g

- Note:**
1. The values above are for the Terminal in its initial state.
 2. The contact resistance given is for 1 A at 5 VDC.
 3. The value given for current consumption is for when all points are ON and includes the relay coil current for the G6D. It does not include the current for external loads or error output.

G70D-R6M□1-B7A (Power MOS FET Relay Outputs)

Item		Specification
Contacts		16 SPST-NO contacts
Isolation method		Photocoupler
Operating time		6 ms max.
Release time		10 ms max.
Output ON resistance		2.4 Ω max.
Current leakage when the relay is closed		10 μA max. (at 125 VDC)
Insulation resistance		100 MΩ min. (500 V)
Dielectric strength		1,000 VAC, 1 min between each terminal and external parts
Noise immunity		Power supply normal: 600 V, 10 min; pulse width: 100 ns to 1 μs Power supply common: 1.5 kV, 10 min; pulse width: 100 ns to 1 μs Transmission path wrapping: 1.5 kV, 10 min; pulse width: 100 ns to 1 μs Link Terminal wrapping: 600 V, 10 min; pulse width: 100 ns to 1 μs
Vibration resistance	Destruction	10 to 55 Hz, 1.0-mm double amplitude for 2 hours each in X, Y, and Z directions
	Malfunction	10 to 55 Hz, 0.75-mm double amplitude for 2 hours each in X, Y, and Z directions
Shock resistance	Destruction	300 m/s ²
	Malfunction	100 m/s ²
Operating voltage range		24 VDC ^{+10%} / _{-15%}
Current consumption (See note.)		24 VDC, approx. 300 mA
Cable length (between Unit and connected device)		Depends on the load
Color of indicators		Operation indicator: orange Power supply indicator: green (red for errors)
Coil surge suppressor		Diode (400 V, 300 mA)
Ambient temperature		Operating: 0 to 55°C Storage: -20 to 65°C
Ambient humidity		Operating: 35% to 85%
Mounting strength		No damage when 49-N pull is applied for 1 s each in all directions (only 9.8-N pull in direction of DIN track)
Terminal strength		Tightening strength: 0.78 to 0.98 N·m Tensile strength: 49 N for 1 minute
Weight		Approx. 230 g

Note: 1. The values above are for the Terminal in its initial state.

2. The value given for current consumption is for when all points are ON and includes the input current for the G3DZ. It does not include the current for external loads or error output.

■ Ratings

Relay Specifications

The following specifications are for the G6D when it is mounted on the G70D. They are not the specifications for the G6D by itself.

Coil Ratings (for each G6D Relay)

Rated voltage	Rated current	Coil resistance	Must-operate voltage	Must-release voltage	Maximum allowable voltage	Power consumption
24 VDC	10.5 mA	2,880 Ω	70% max. (See note 1.)	10% min.	130%	Approx. 200 mW

Note: 1. The must-operate voltage is 70% max. if the Relay is mounted upside down.

2. The values for rated current and coil resistance are for a coil temperature of 23°C with a tolerance of ±10%.

3. The values for operating characteristics are for a coil temperature of 23°C.

4. The maximum allowable voltage is the maximum value of the allowable voltage range for the relay coil operating power supply. It does not apply in the case of continuous voltages.

5. The rated current includes the Link Terminal's rated current.

Contact Ratings (for each G6D Relay)

Load	Resistive load (cosφ = 1)
Rated load	250 VAC 3 A, 30 VDC 3 A
Rated carry current	3 A
Maximum switching voltage	250 VAC, 30 VDC
Maximum switching current	3 A
Maximum switching capacity (reference value)	750 VA, 90 W
Minimum permissible load (reference value; see note 2)	5 VDC, 10 mA
Electrical life	100,000 operations min. (at the rated load and a switching frequency of 1,800 operations/hour)
Mechanical life	20,000,000 operations min. (at a switching frequency of 18,000 operations/hour)

- Note:** 1. The maximum carry current for output power supply common terminals (B0 to B6) is 3 A.
 2. This value fulfills the P reference value for switching at a frequency of 120 times per minute (ambient operating environment and determination criteria according to JIS C5442).

Power MOS FET Relay Specifications

The following specifications are for the G3DZ when it is mounted on the G70D. They are not the specifications for the G3DZ by itself.

Input (for each G3DZ Power MOS FET Relay)

Rated voltage	Operating voltage	Must-operate voltage level	Must-release voltage level	Input impedance	Rated current
24 VDC	19.2 to 28.8 VDC	19.2 VDC max.	1 VDC max.	4 kΩ ±20%	8.2 mA ±20%

Note: The rated current includes the Link Terminal's LED current.

Output (for each G3DZ Power MOS FET Relay)

Load voltage	Load current	Inrush current
3 to 264 VAC 3 to 125 VDC	100 μA to 0.3 A	6 A (10 ms)

Engineering Data

The following data was obtained from measurements of samples taken from the production line. Relays are mass produced and performance characteristics will differ from product to product. Therefore, use the following data as reference only.

G6D-1A (24 VDC) (Power Relay Mounted to G70D-R6R□1-B7A)

Life Expectancy

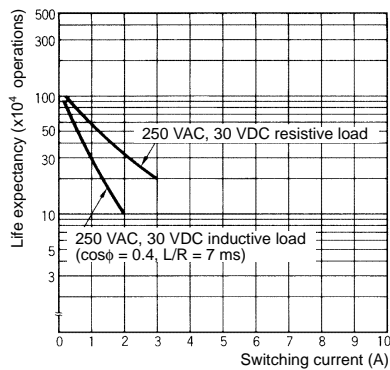

Note: The above graph shows the characteristics for the Relay when it is mounted to the G70D.

Maximum Switching Capacity

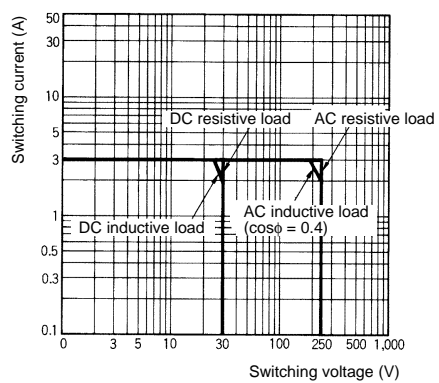

Note: The above graph shows the characteristics for the Relay when it is mounted to the G70D.

G3DZ-2R6PL (Power MOS FET Relay Mounted to G70D-R6M□1-B7A)

Load Current vs. Ambient Temperature

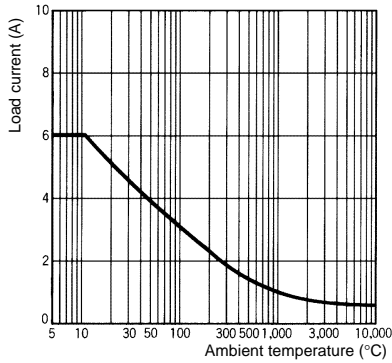

Note: The above graph shows the characteristics for the Relay when it is mounted to the G70D.

Inrush Current Resistivity (Non-repetitive)

(The value will be less than half for repetitive inrush currents.)

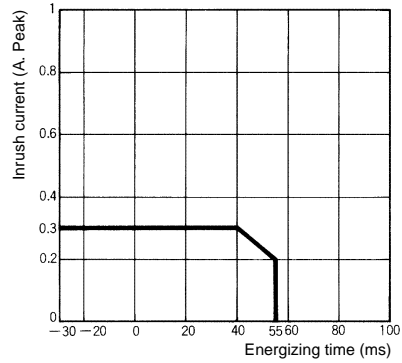

Note: The above graph shows the characteristics for the Relay when it is mounted to the G70D.

Operation

■ I/O Combinations

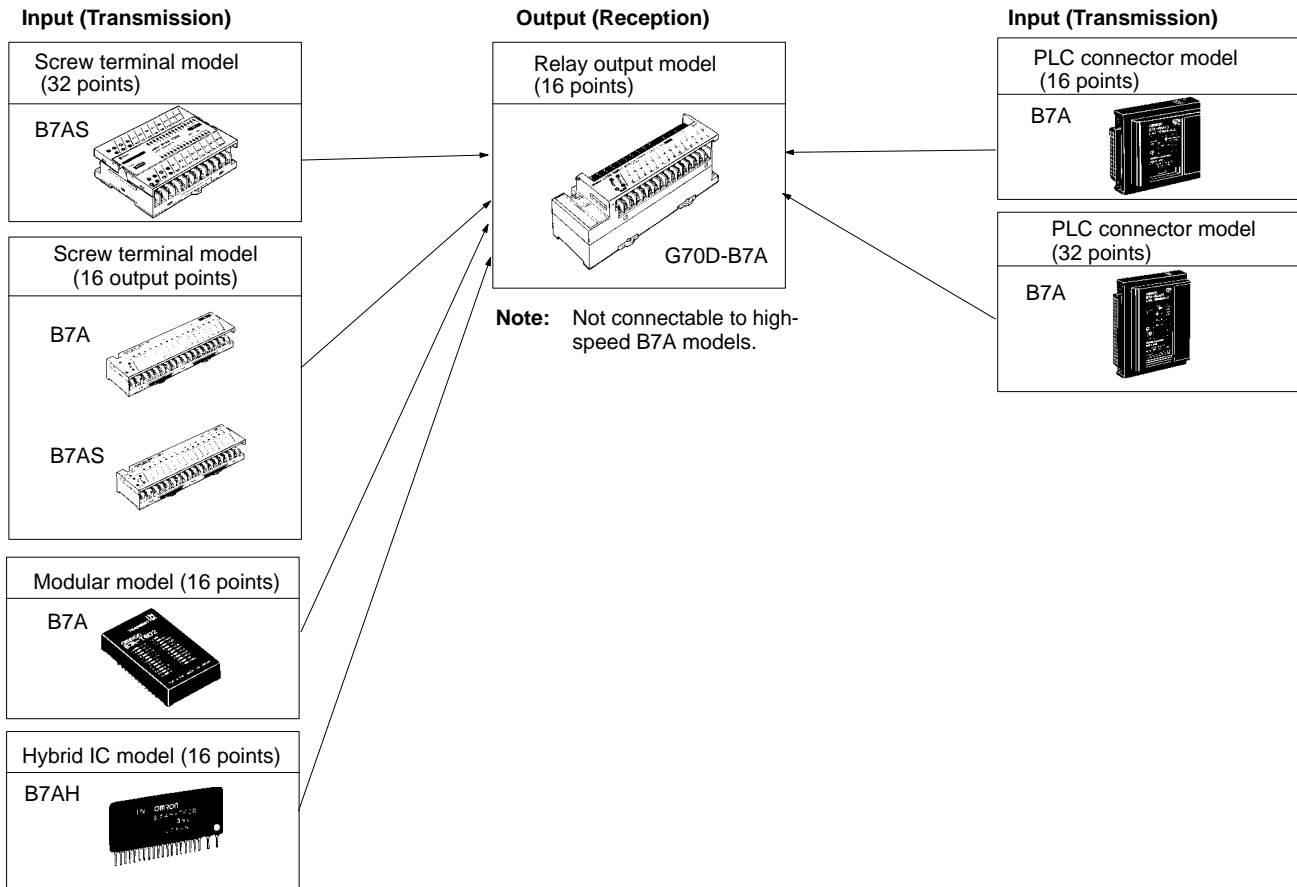

Dimensions

Note: All units are in millimeters unless otherwise indicated.

G70D-R6□□1-B7A

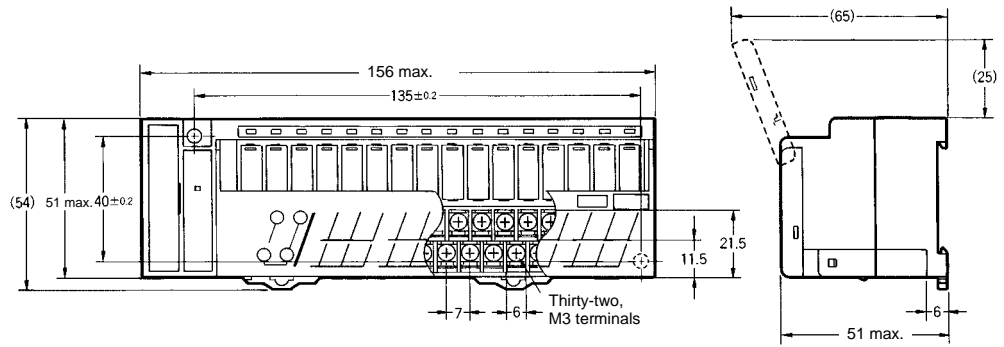
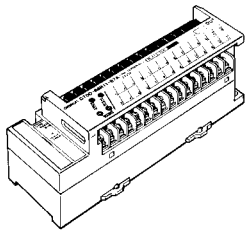

Installation

Internal Circuits

G70D-R6R11-B7A, G70D-R6M11-B7A
 G70D-R6R31-B7A, G70D-R6M31-B7A

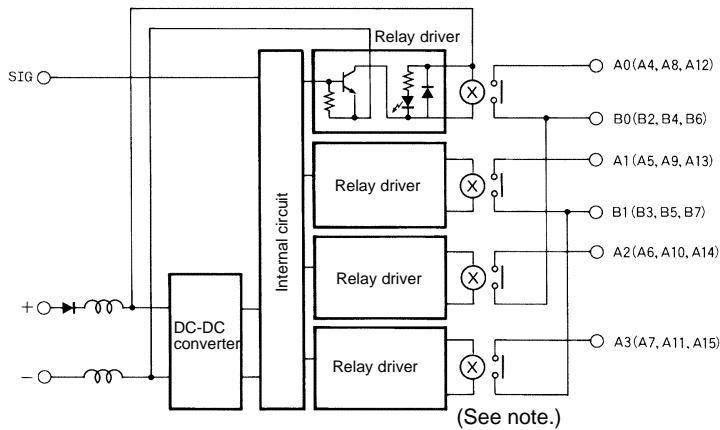

Note: The above diagram is for G70D-R6R□□1-B7A models (G6D-mounting). With G70D-R6M□□1-B7A models, G3DZ Power MOS FET Relays are used.

Terminal Arrangement

G70D-R6□□□-B7A

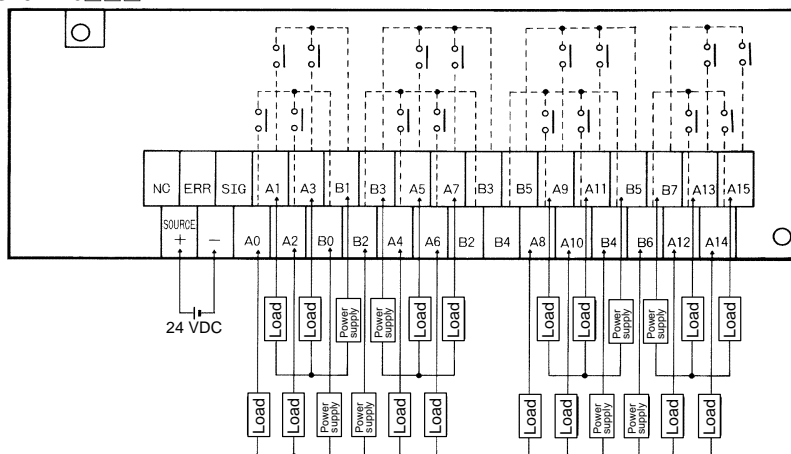

Note: 1. Internal connections are indicated by dotted lines in the above diagram.
 2. Terminals B2, B3, B4, and B5 come in pairs. Connect the power supply to either terminal.

Precautions

General

Electric Shock

Do not touch charged parts of relay terminals or socket terminals while power is supplied. Doing so may result in electric shock.

Wiring

Be sure to turn the power OFF before performing wiring. Do not touch the terminal block while power is supplied unless the cover is mounted. Doing so may result in electric shock.

Be sure to apply the specified voltage to input terminals. Applying an incorrect voltage may prevent the product from operating with its rated performance characteristics, or may cause damage or burning.

Relay Models

Do not use the product for loads that exceed the rated values for switching capacity (e.g., switching voltage and switching current). If the ratings are exceeded the product may not be able to operate with its rated performance characteristics due to factors such as insulation failure, contact failure, or contact welding. It may even result in damage to or burning of the relay.

The lifetime of relays varies significantly with the switching conditions. Be sure to confirm the required performance characteristics by testing the relay under actual operating conditions, and use the relay at a frequency at which it can perform with the required performance characteristics. Continued use of the relay in a state where it cannot maintain the rated characteristics may eventually result in damage to the insulation between circuits or burning of the relay.

Do not use the product in locations subject to flammable or explosive gases. Doing so may result in fire or explosion due to the arcing that accompanies the switching mechanism and heating up of the relay.

No-contact Output (Transistor, Power MOS FET Relay, and SSR Output)

Do not use the product for loads that exceed the rated output current. Doing so may damage output elements and result in short-circuiting or open circuits.

When using the product for DC inductive loads, connect a diode that will prevent reverse voltages. Not doing so may damage output elements and result in short-circuiting or open circuits.

Correct Use

Link Terminals with Relay Outputs

This Link Terminal is for relay output.

G70D-R6R□1-B7A Link Terminals use 24-VDC G6D-1A Relays and G70D-R6M□1-B7A Link Terminals use 24-VDC G3DZ-2R6PL Relays.

When replacing relays, use the yellow Relay Removal Tool at the corner of the screw terminal (except for G7TC).

Do not mount or dismount relays with the power supplied.

Opening the Front Cover (Rotating Type):

Hold the two bottom corners of the front cover (labelled A in the diagram below), and lift upwards to open.

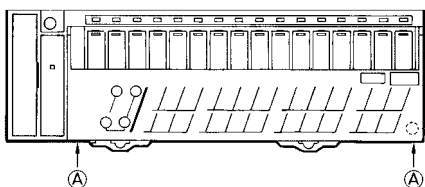

Replacing Relays

Do not mount or dismount relays with the power supplied. Doing so may result in electric shock or malfunction.

When replacing relays, use the yellow Relay Removal Tool at the corner of the screw terminal (except for G7TC).

Relays must be inserted vertically so that the legs do not bend. Not inserting relays properly may result in malfunction or heating.

Wiring

Be sure that terminal polarity, wiring between the transmission lines and power supply, and the voltage specifications for I/O power supplies are correct.

Do not mount or remove connectors with the power supplied. Doing so may result in malfunction.

Locks for Connecting Cables

Ensure that the connectors for connecting cables are securely locked before supplying power.

Installation

Do not install the product in the following locations. Doing so may result in failure or malfunction.

- Locations subject to direct sunlight
- Locations subject to temperatures outside the range 0 to 55°C
- Locations subject to humidity outside the range 10% to 90%, or locations subject to condensation as the result of severe changes in temperature
- Locations subject to corrosive or flammable gases
- Locations subject to dust (especially iron dust) or salts
- Locations subject to shock or vibration
- Locations subject to exposure to water, oil, or chemicals

Tightening Torque for Mounting Screws

Tighten the mounting screws for all Units to the specified torques to prevent malfunction.

- Tightening torque for terminal screws:
0.78 to 1.18 N·m
- When directly mounting to panel with screws:
0.59 to 0.98 N·m

Cleaning

Do not use thinners to clean the product. Doing so will dissolve or discolor the surface of the product.

Mounting

Be sure not to drop the product or apply excessive shock to the product when mounting. Doing so will result in failure or malfunction.

Disassembly

Do not attempt to disassemble, repair, or modify the product. Any attempt to do so may result in incorrect operation or electric shock.

Incorporates 16 Input and 16 Output Points in a Single Unit

- Normal-speed or high-speed transmission is possible using a selection switch.
- Compact and space-saving.



Ordering Information

■ Model Number Legend

B7AM - 6 B S
1 2 3 4

1. Classification

M: I/O combination model

2. Number of I/O

6: Sixteen input points and sixteen output points

3. Input/Output Configuration

B: NPN input and 100-mA NPN open collector output per point

4. Appearance

S: Screw terminals

■ Product List

Refer to page 114 for details.

■ I/O Combinations

Refer to pages 1 to 5 for details.

Specifications

■ Characteristics

General

	Normal speed	High speed
Communications method	Unidirectional, time-division multiplex	
Transmission distance	500 m max.	100 m max. (see note 1)
I/O delay time	Typical: 19.2 ms; 31 ms max.	Typical: 3 ms; 5 ms max.
Minimum input time (see note 2)	16 ms	2.4 ms
Operating voltage range	12 to 24 VDC (10.8 to 26.4 VDC)	
Insulation resistance	100 M Ω min. (500 V) between each terminal and external parts	
Dielectric strength	1,000 VAC, 50/60 Hz for 1 min between each terminal and external parts	
Noise immunity (see note 3)	Noise level: 1.5 kV; pulse width: 100 ns to 1 μ s	
Vibration resistance	10 to 55 Hz, 1.5-mm double amplitude	
Shock resistance	300 m/s ²	
Ambient temperature	Operating: -10 to 55°C (with no icing) Storage: -25 to 65°C (with no icing)	
Ambient humidity	Operating: 35% to 85% (with no condensation)	

Note: 1. A shielded transmission cable or a VCTF cable with a thickness of 0.75 mm² minimum must be used for signal transmission. If the VCTF cable is used, however, the transmission distance will be 10 m maximum regardless of whether or not independent power supplies for the Input and the Output Link Terminals are used.

2. The minimum input time is required for the B7AM to read an input signal.

3. As for the high-speed model, these values are possible without grounding the shielded line.

Screw Terminal Model

Item	B7AM-6BS
I/O delay time	Normal speed (typical 19.2 ms); high speed (typical 3 ms) (switch selectable) (see note 4)
Current consumption (see note 1)	240 mA max. with all input/output terminals ON
Operating voltage range	12 to 24 VDC
Compatible inputs (see note 2)	Switches, two-wire sensors with DC output, three-wire NPN sensors
Input logic	Active low
Input voltage range	0 VDC to supply voltage
Input current range	-6 to -3 mA/point (current flowing from input terminals)
Minimum input time	Normal speed: 16 ms; high speed: 2.4 ms
ON/OFF threshold	No-contact input: ON voltage: 4 V max. OFF voltage: 6 V min. Contact input: ON discrimination resistance: 660 Ω max. OFF discrimination resistance: 2 k Ω min.
Output configuration	NPN open collector
Rated load voltage	5 to 24 VDC
Output residual voltage	0.8 V max.
Output current	Sync. current, 100 mA max./ point
Error processing	HOLD/LOAD OFF is set using a selection switch (see note 3)
Mounting strength	No damage when 49-N pull is applied for 1 min each in all directions
Terminal strength	No damage when 49-N pull is applied for 1 min each in all directions
Tightening torque	0.78 to 1.18 N • m
Weight	Approx. 230 g

Note: 1. Consumption when all 16 input/output points are ON. Excludes external sensor current for Input Terminals and external load current and error load current for Output Terminals.

2. Power must be supplied to the three-wire sensor via the positive power supply terminal or from an independent power supply. Two-wire sensors must satisfy the following requirements:

Residual voltage: 4 V max.

Current leakage: 1.5 mA max.

The lower limit of control output: 3 mA (Use a bleeder resistor to eliminate this restriction.)

3. Default settings are 19.2 ms and LOAD OFF.

Nomenclature

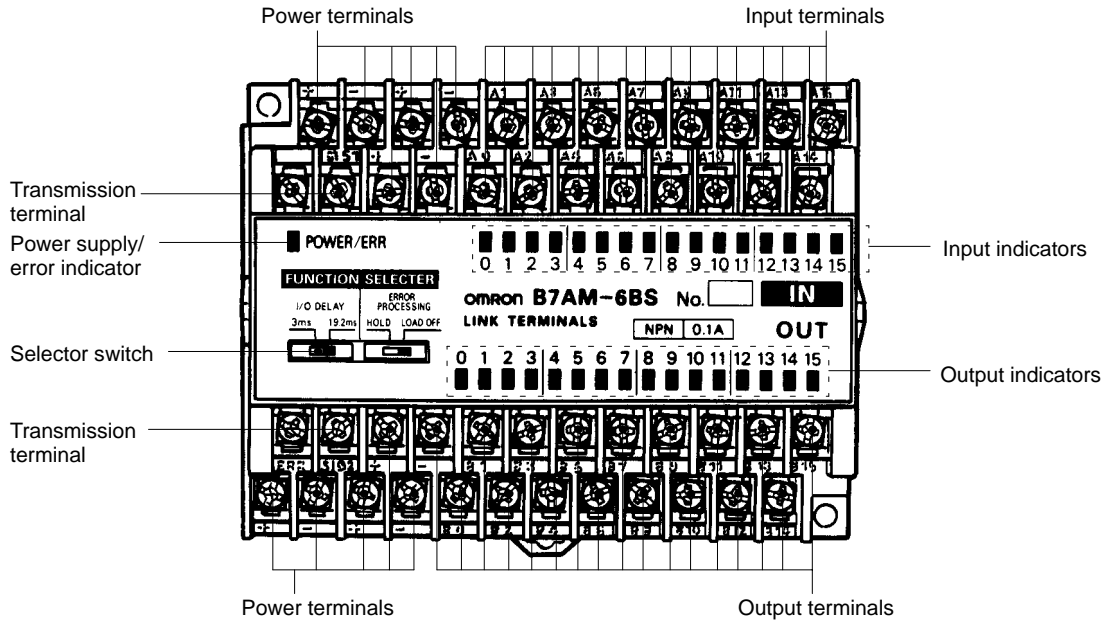

Indicator Operation

Indicator	Function
POWER/ERR	G Lit when power is supplied and the Terminal is operating without error.
	R Lit during transmission errors (SIG2).
	N Not lit when power is not supplied.
I/O	O Lit when the input signals are ON.
	N Not lit when the signals are OFF.

Note: G: Green indicator lit; R: Red indicator lit; O: Orange indicator lit; N: Not lit

Recommended Solderless Terminals

Wire	JIS specifications
0.75 mm ² (AWG#18)	RAV 1.25 to 3.5 (vinyl-insulated round wire) or RAP 1.25 to 3.5 (nylon-insulated round wire)
1.25 mm ² (AWG#16)	

Settings of Selector Switch

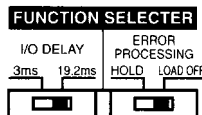

I/O delay selector switch		Error processing selector switch	
3 ms	19.2 ms	HOLD	LOAD OFF
High speed: (typical 3 ms)	Normal speed: (typical 19.2 ms)	When an error occurs, the output holds the state that existed right before the error occurred.	When an error occurs, the output shuts off everything.

Note: Default settings are 19.2 ms and LOAD OFF.

Operation

■ Power Supply

The six positive and six negative terminals on the terminal block are internally connected. Use positive and negative terminals for the power supply terminals and another negative terminal for the negative signal line. Connect the SIG1 terminals to SIG2 terminals for the signal lines.

I/O Delay: Normal Speed

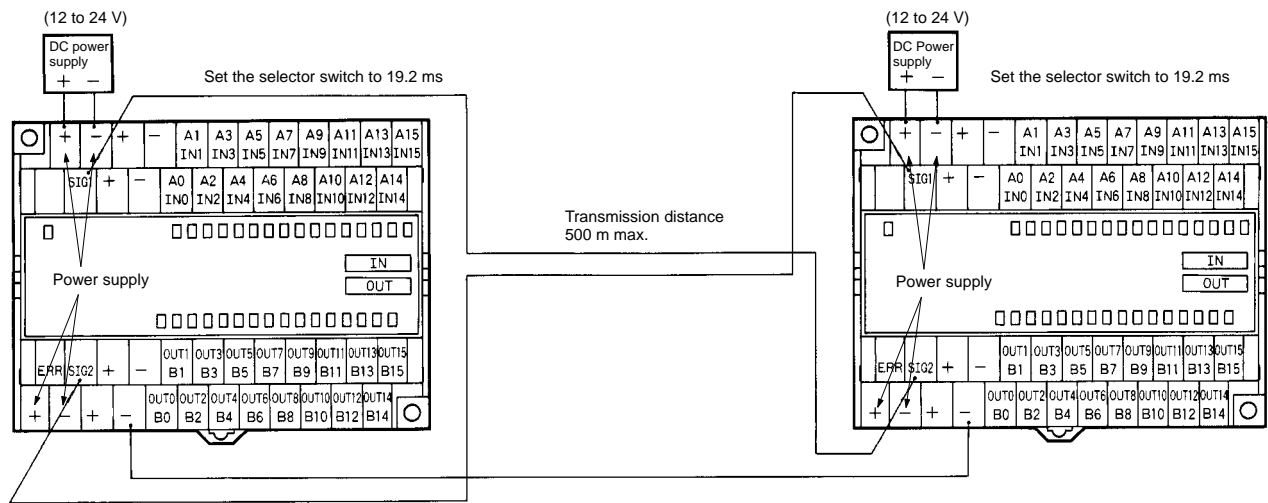

Note: A VCTF cable with a thickness of 0.75 mm² min. must be used for signal transmission.

I/O Delay: High Speed

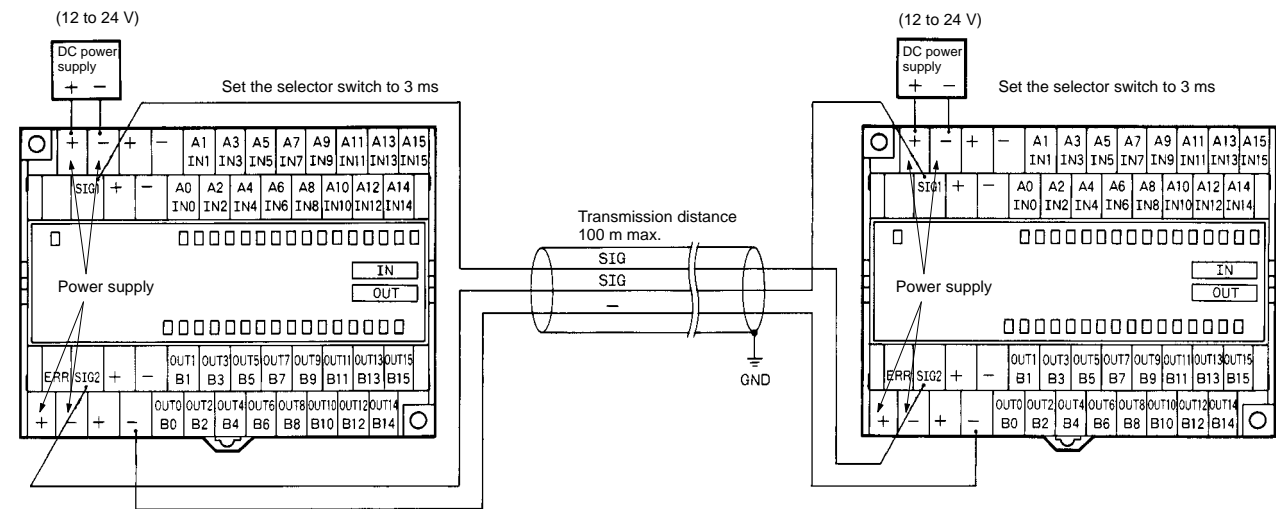

Note: A shielded cable with a thickness of 0.75 mm² min. must be used for signal transmission. It is recommended that the shield be grounded.
The maximum transmission distance is 10 m if a VCTF wire with a thickness of 0.75 mm² is used instead of a shielded cable for the transmission path.

■ Operation

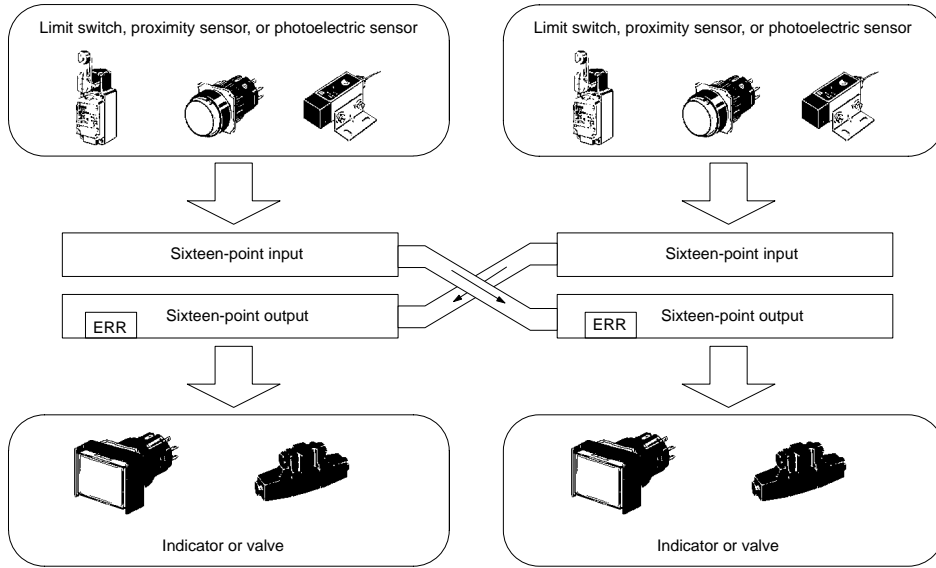

Note: The B7AM transmits input signals from SIG1 (input terminal) to SIG2 (output terminal). If an error results while the B7AM is transmitting input signals, an error signal is output from the output side only.

Dimensions

Note: All units are in millimeters unless otherwise indicated.

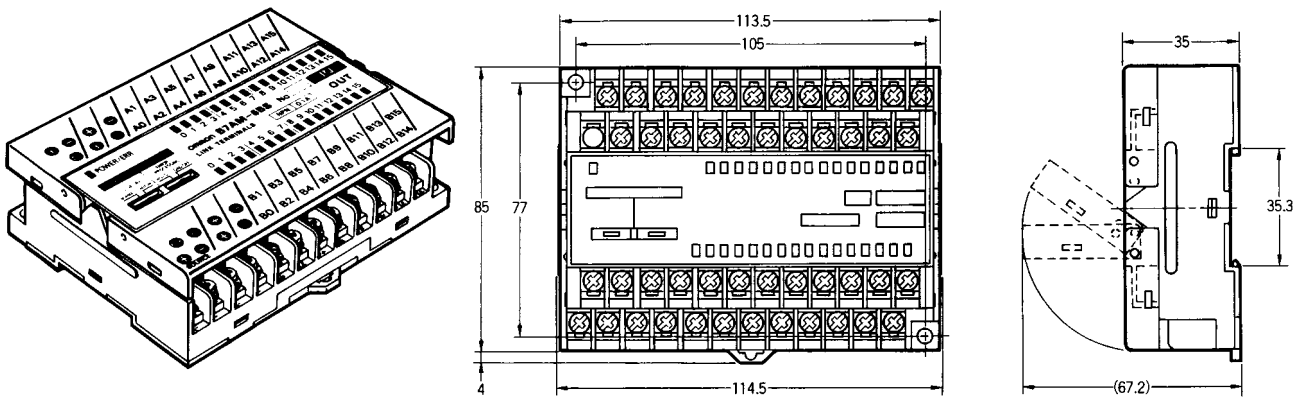

Installation

Internal Circuits and Terminal Arrangement

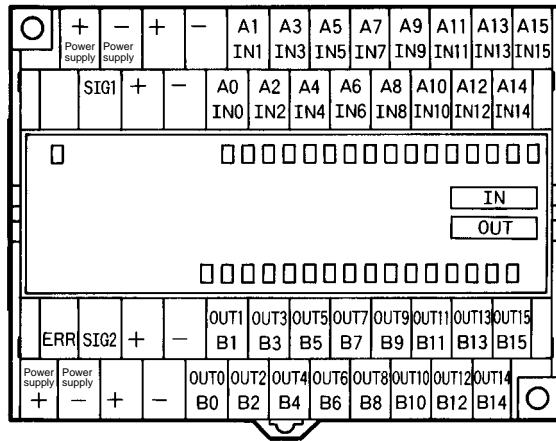
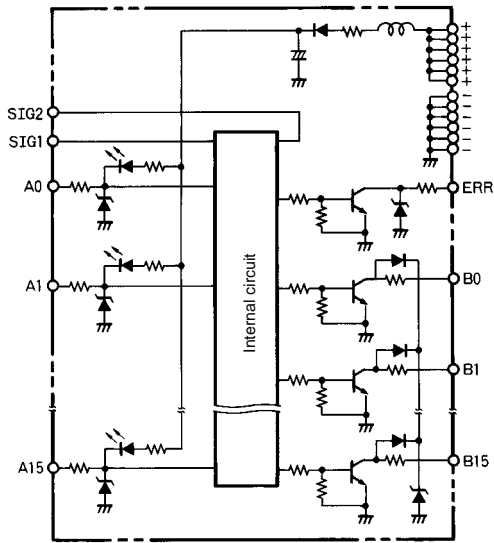

Transmission Units Transmitting Input and Output Signals

- Transmit eight input signals and eight output signals over three wires (or four wires if only one terminal has power supply).
- Transistor and relay inputs can be connected to the input terminals.
- Compact and space-saving.



Ordering Information

■ Model Number Legend

B7AM - 8 □ □ □
1 2 3 4 5

1. Classification

M: I/O combination model

2. Number of I/O

8: Eight input points and eight output points

3. Input/Output Configuration

B: NPN input and 100-mA NPN open collector output per point

F: PNP input and 100-mA PNP open collector output per point

4. Error Processing

1: HOLD

3: LOAD OFF

5. I/O Delay Time (Typical)

1: 19.2 ms (Screw terminals)

6: 3 ms (Screw terminals)

■ Product List

Refer to page 114 for details.

■ I/O Combinations

Refer to pages 1 to 5 for details.

Specifications

■ Characteristics

General

	Normal speed	High speed
Communications method	Unidirectional, time-division multiplex	
Transmission distance (see note 1)	500 m max.	100 m max. (see note 2)
I/O delay time	Typical: 19.2 ms; 31 ms max.	Typical: 3 ms; 5 ms max.
Minimum input time (see note 3)	16 ms	2.4 ms
Operating voltage range	12 to 24 VDC (10.8 to 26.4 VDC) (see note 1)	
Insulation resistance	100 M Ω min. (500 V) between each terminal and external parts	
Dielectric strength	1,000 VAC, 50/60 Hz for 1 min between each terminal and external parts	
Noise immunity (see note 4)	Noise level: 1.5 kV; pulse width: 100 ns to 1 μ s (on transmission line due to coupling)	
Vibration resistance	10 to 55 Hz, 1.5-mm double amplitude	
Shock resistance	300 m/s ²	
Ambient temperature	Operating: -10 to 55°C (with no icing) Storage: -25 to 65°C (with no icing)	
Ambient humidity	Operating: 35% to 85% (with no condensation)	

- Note:**
1. The transmission distance values stated in this table are possible if the Input or Output Link Terminal is connected to an independent power supply. If a single power supply is connected to the Input or Output Link Terminal, the supply voltage must be 24 VDC \pm 10%, in which case the transmission distance of a normal-speed model is 100 m maximum and that of a high-speed model is 50 m maximum.
 2. A shielded transmission cable or a VCTF cable with a thickness of 0.75 mm² minimum must be used for signal transmission. If the VCTF cable is used, however, the transmission distance will be 10 m maximum regardless of whether or not independent power supplies for the Input and the Output Link Terminals are used.
 3. The minimum input time is required for the B7AM to read an input signal.
 4. As for the high-speed model, these values are possible without grounding the shielded line.

Screw Terminal Models

Item	B7AM-8B11/-8B31/-8B16/-8B36	B7AM-8F31
Compatible inputs (see note 1)	Switches, two-wire sensors with DC output, three-wire NPN sensors	Switches, two-wire sensors with DC output, three-wire PNP sensors
I/O delay time	B7AM-8B□1: normal speed (typical 19.2 ms); B7AM-8B□6: high speed (typical 3 ms)	Normal speed (typical 19.2 ms)
Input logic	Active low	Active high
Current consumption (see note 2)	120 mA max. with all input/output terminals ON	
Operating voltage range	12 to 24 VDC	
Input voltage range	0 VDC to supply voltage	
Input current range	-6 to -3 mA/point (current flowing from input terminals)	3 to 6 mA/point (current flowing from input terminals)
Minimum input time	B7AM-8B□1: 16 ms; B7AM-8B□6: 2.4 ms	
ON/OFF threshold	No-contact input: ON voltage: 4 V max. OFF voltage: 6 V min. Contact input: ON discrimination resistance: 660 Ω max. OFF discrimination resistance: 2 kΩ min.	
Output configuration	NPN open collector	PNP open collector
Rated load voltage	5 to 24 VDC	
Output residual voltage	0.8 V max.	
Output current	Sync. current, 100 mA max./ point	
Error processing	B7AM-8B1□: HOLD; B7AM-8B3□: LOAD OFF	LOAD OFF
Mounting strength	No damage when 49-N pull is applied for 1 min each in all directions	
Terminal strength	No damage when 49-N pull is applied for 1 min each in all directions	
Tightening torque	0.78 to 1.18 N • m	
Weight	Approx. 140 g	

- Note:**
- Power must be supplied to the three-wire sensor via the positive power supply terminal or from an independent power supply. Two-wire sensors must satisfy the following requirements:
Residual voltage: 4 V max.
Current leakage: 1.5 mA max.
The lower limit of control output: 3 mA (Use a bleeder resistor to eliminate this restriction.)
 - Consumption when all 8 input/output points are ON. Excludes external sensor current for Input Terminals and external load current and error load current for Output Terminals.

Nomenclature

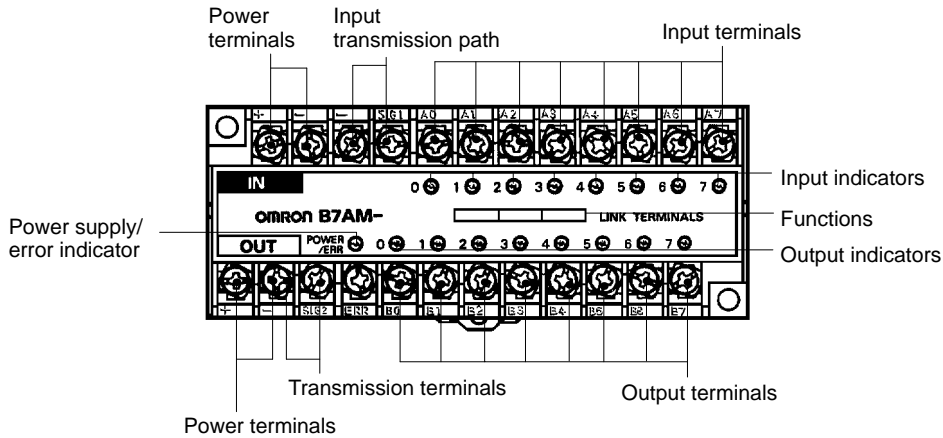

Indicator Operation

Indicator	Function
POWER/ERR	G Lit when power is supplied and the Terminal is operating without error.
	R Lit during transmission errors (SIG2).
	N Not lit when power is not supplied.
I/O	O Lit when the input signals are ON.
	N Not lit when the signals are OFF.

Note: G: Green indicator lit; R: Red indicator lit; O: Orange indicator lit; N: Not lit

Recommended Solderless Terminals

Wire	JIS specifications
0.75 mm ² (AWG#18)	RAV 1.25 to 3.5 (vinyl-insulated round wire) or RAP 1.25 to 3.5
1.25 mm ² (AWG#16)	(nylon-insulated round wire)

Functions

Display	Description
	I/O configuration Indicates the compatible transistor type.
	Output current Indicates the rated output current value of the B7A per point.
	I/O delay time Indicates the typical I/O delay time of the B7A. Use a combination of an Input and Output Link Terminal with the same I/O delay time.

Operation

■ Power Supply

The two positive and three negative terminals on the terminal block are internally connected on the terminal block. Use a positive terminal and negative terminal for the power supply terminals and another negative terminal for the negative signal line. Connect the SIG1 terminals to SIG2 terminals for the signal lines.

I/O Delay: Normal Speed

Connection of Independent Power Supplies

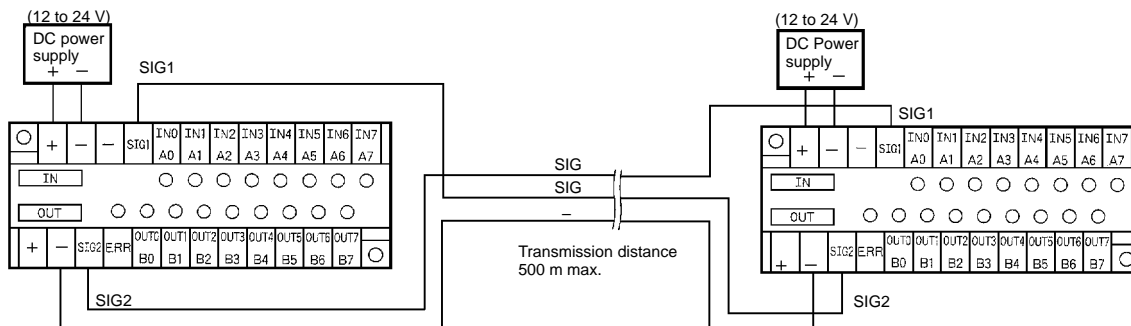

Note: A VCTF cable with a thickness of 0.75 mm² min. must be used for signal transmission.

Connection of Single Power Supply to Input or Output Terminal

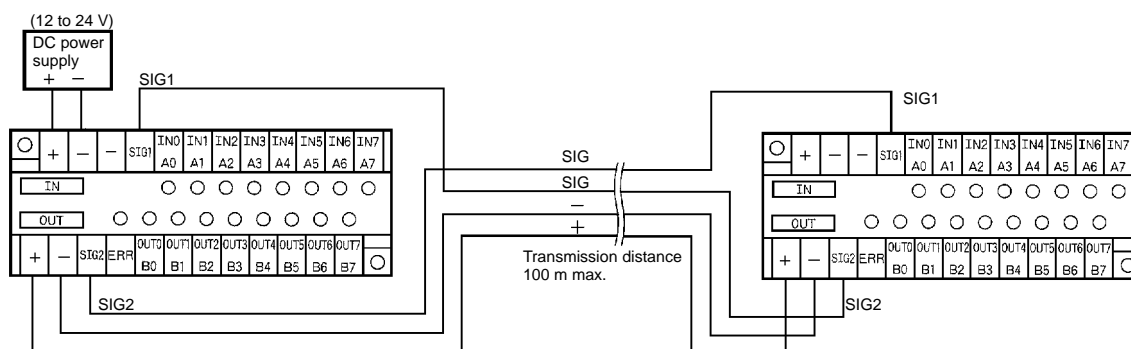

Note: In this example, a VCTF transmission cable with a thickness of 0.75 mm² min. is used, through which a current of 1.8 A max. can be transmitted.

I/O Delay: High Speed

Connection of Independent Power Supplies

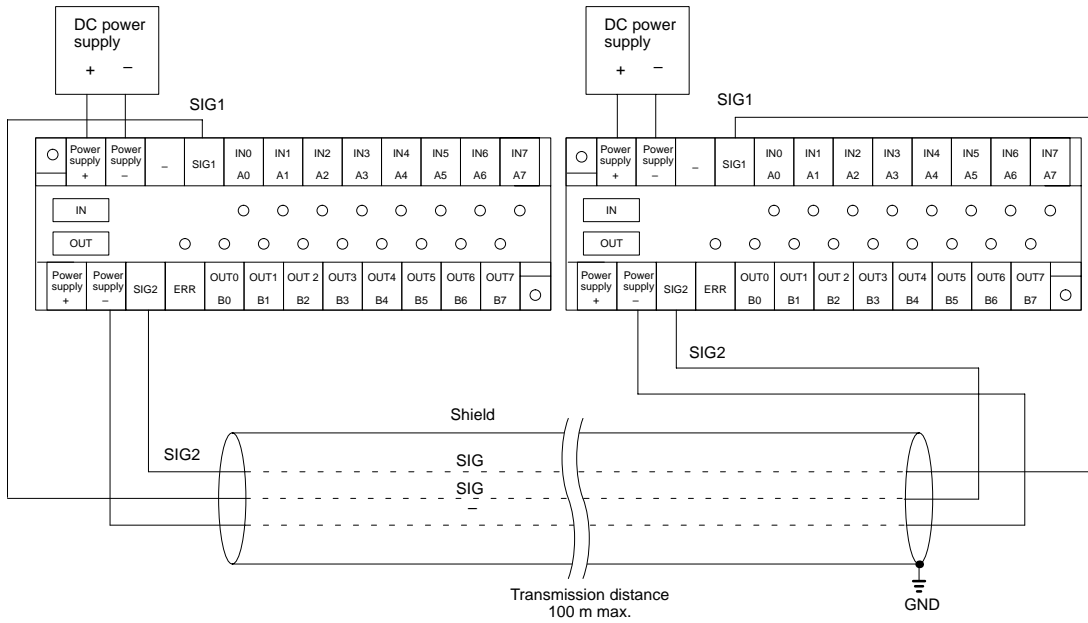

Note: A shielded cable with a thickness of 0.75 mm² min. must be used for signal transmission. It is recommended that the shield be grounded.
 The maximum transmission distance is 10 m if a VCTF wire with a thickness of 0.75 mm² is used instead of a shielded cable for the transmission path.

Connection of Single Power Supply to Input or Output Terminal

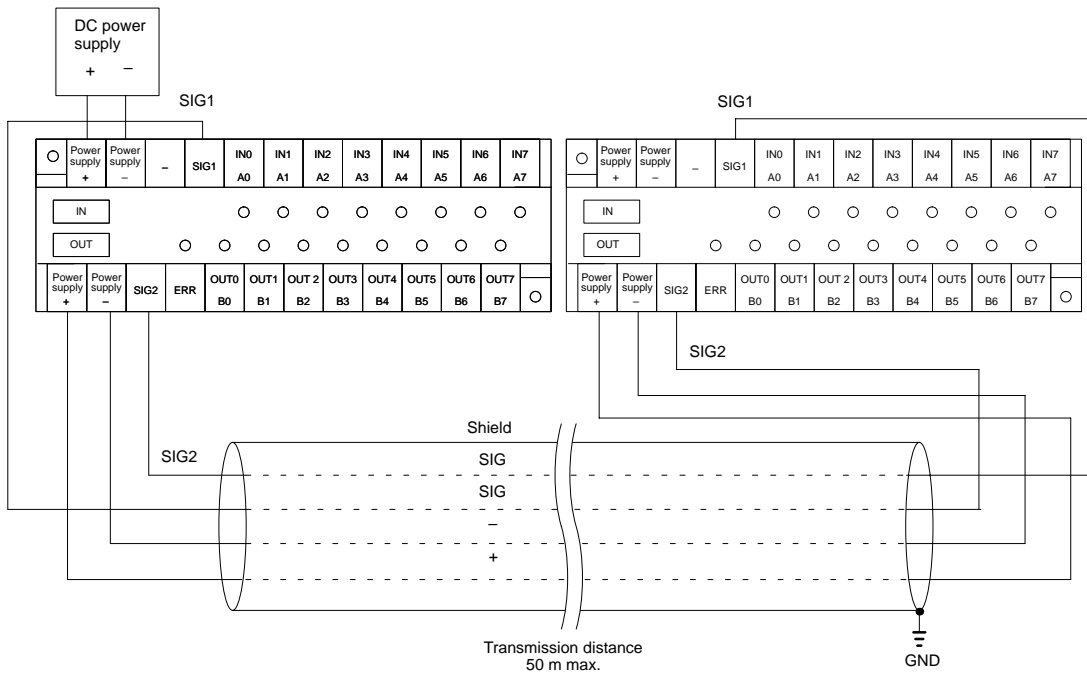

Note: In this example, a shielded transmission cable with a thickness of 0.75 mm² min. is used, through which a current of 1.8 A max. can be transmitted. It is recommended that the shield be grounded.
 The maximum transmission distance is 10 m if a VCTF wire with a thickness of 0.75 mm² is used instead of a shielded cable for the transmission path.

■ Operation

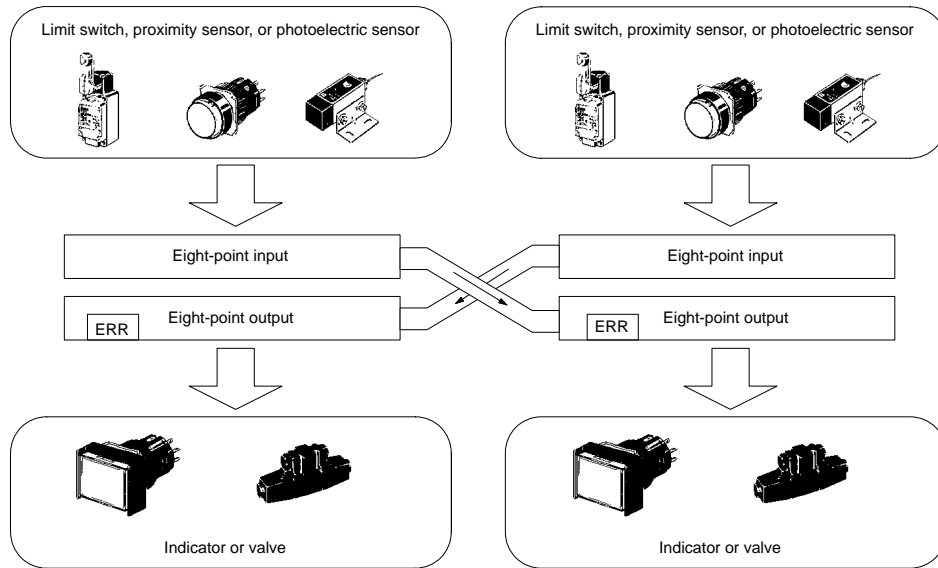

Note: The B7AM transmits input signals from SIG1 (input terminal) to SIG2 (output terminal). If an error results while the B7AM is transmitting input signals, an error signal is output from the output side only.

Dimensions

Note: All units are in millimeters unless otherwise indicated.

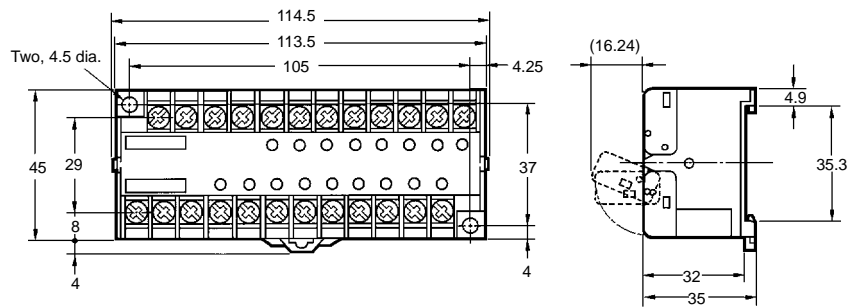
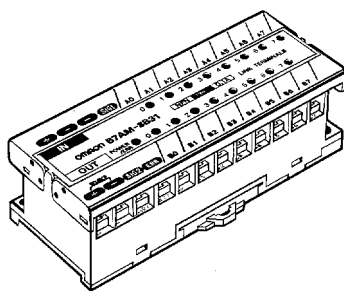

Installation

Internal Circuits and Terminal Arrangement

B7AM-8B11/-8B16/-8B31/-8B36
 (Input, Active Low/Output, NPN Open Collector)

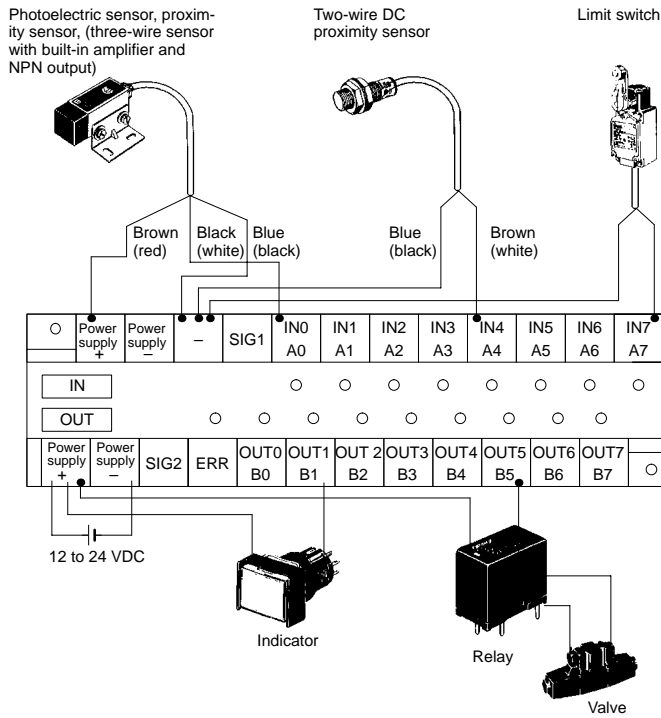
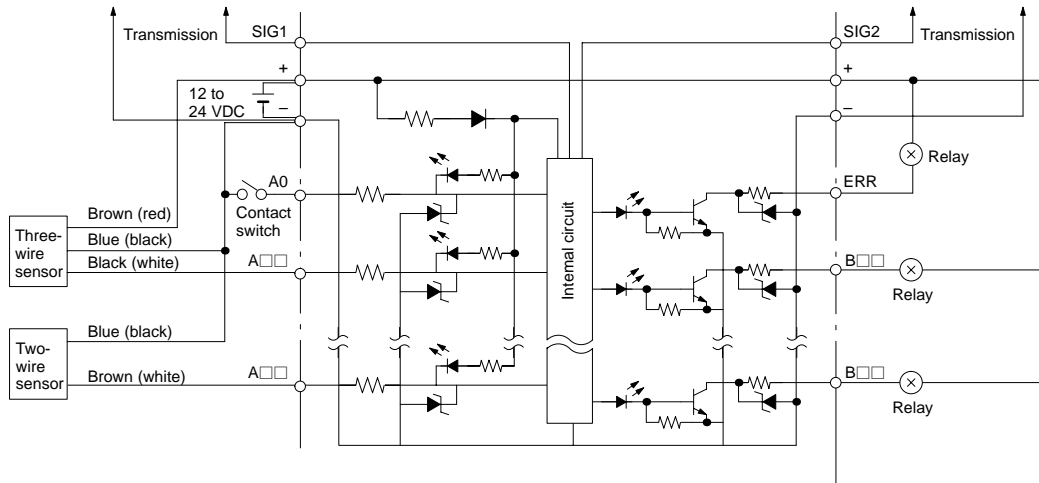

Note: The wire colors have been changed in accordance with the revision of the Japanese Industrial Standards for photoelectric sensors and proximity sensors. The colors in parentheses refer to the old colors.

B7AM-8F31
 (Input, Active High/Output, PNP Open Collector)

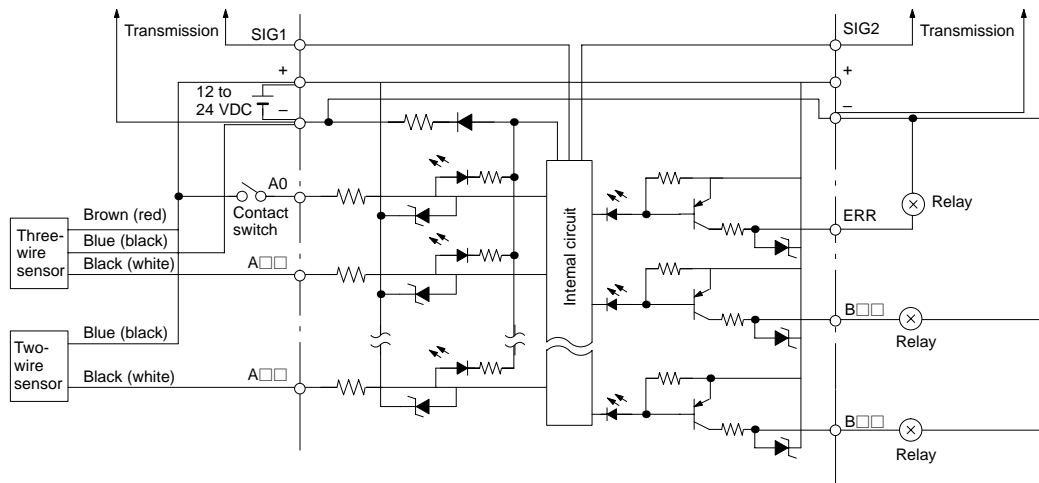

Photoelectric sensor, proximity sensor, (three-wire sensor with built-in amplifier and NPN output)

Two-wire DC proximity sensor

Limit switch

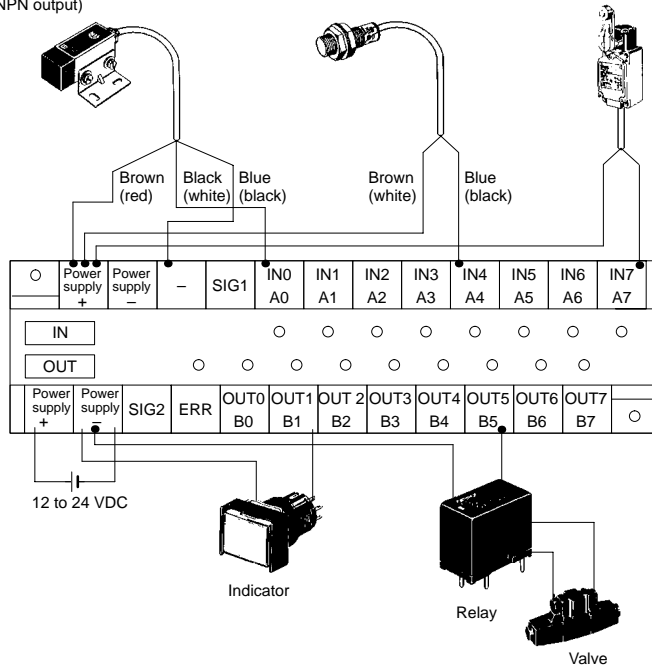

Slim 16-point Hybrid IC Link Terminals that Mount to PCBs

- Dimensions of input model: 46 × 9 × 20 mm (W × D × H)
Dimensions of output model: 51 × 9 × 20 mm (W × D × H)
- Normal-speed models (typical I/O delay time: 19.2 ms) and high-speed models (typical I/O delay time: 3 ms) available.

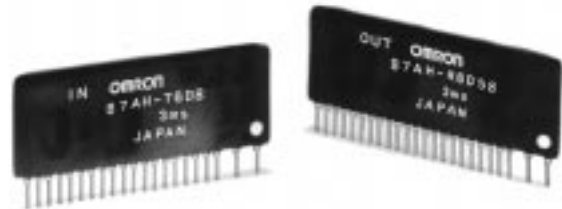

Ordering Information

■ Product List Input Models

I/O classification	Wiring	Appearance	I/O delay time	Input configuration	Model
Input (transmission)	Hybrid IC		Normal speed (typical: 19.2 ms)	CMOS input	B7AH-T6D3
			High speed (typical: 3 ms)		B7AH-T6D8

Output Models

I/O classification	Wiring	Appearance	I/O delay time	Output configuration	Error processing	Model
Output (reception)	Hybrid IC		Normal speed (typical: 19.2 ms)	CMOS output 2 mA/point	HOLD LOAD OFF (Selectable)	B7AH-R6D53
			High speed (typical: 3 ms)			B7AH-R6D58

Specifications

■ Characteristics

General

	Normal speed	High speed
Communications method	Unidirectional, time-division multiplex	
Transmission distance (See note 1.)	500 m max.	100 m max. (See note 2.)
I/O delay time	Typical: 19.2 ms; 31 ms max.	Typical: 3 ms; 5 ms max.
Minimum input time (See note 3.)	16 ms	2.4 ms
Operating voltage range	Transmission circuit (+V, -V): 12 to 24 VDC (10.8 to 26.4 VDC) (See note 1.) Logic circuit (VDD, VSS): 5 VDC \pm 10% (4.5 to 5.5 VDC)	
Insulation resistance	20 M Ω min. (250 V) between each pin and external parts	
Dielectric strength	250 VAC, 50/60 Hz, 1 min between each pin and external parts	
Noise immunity (See note 4.)	Noise level: 1.5 kV; pulse width: 100 ns to 1 μ s (on transmission line due to coupling)	
Vibration resistance	10 to 55 Hz, 1.5-mm double amplitude	
Shock resistance	300 m/s ²	
Ambient temperature	Operating: -10 to 55°C (with no icing or condensation) Storage: -25 to 65°C (with no icing or condensation)	
Ambient humidity	Operating: 35% to 85%	

- Note:**
1. The transmission distance values stated in this table are possible if the Input or Output Link Terminal is connected to an independent power supply. If a single power supply is connected to the Input or Output Link Terminal, the supply voltage must be 24 VDC \pm 10%, in which case the transmission distance of a normal-speed model is 100 m maximum and that of a high-speed model is 50 m maximum. Refer to *Power Supply* on page 68 for details.
 2. A shielded transmission cable or a VCTF cable with a thickness of 0.75 mm² minimum must be used for signal transmission. If the VCTF cable is used, however, the transmission distance will be 10 m maximum regardless of whether or not independent power supplies for the Input and the Output Link Terminals are used.
 3. The minimum input time is required for the B7AH to read an input signal.
 4. This is the value for the inductive noise on the transmission line measured using a noise tester. For high-speed models, it is the value without the shield line connected to ground.

■ I/O Specifications

Input

Item	B7AH-T6D3, B7AH-T6D8	
Input configuration	CMOS input	
Input logic	Active high	
I/O delay time	B7AH-T6D3: Normal speed (typical: 19.2 ms); B7AH-T6D8: High speed (typical: 3 ms)	
Current consumption (see note)	Logic circuit: 20 mA max.; Transmission circuit: 30 mA max.	
Input	Input voltage	0 to VDD (V)
	Input current	0.04 to 0.06 mA/point
Minimum input time	B7AH-T6D3: 16 ms B7AH-T6D8: 2.4 ms	
ON/OFF threshold	ON voltage	VDD(V) \times 0.7 min. (3.15 V min. for VDD = 4.5 V; 3.5 V min. for VDD = 5 V; 3.85 V min. for VDD = 5.5 V)
	OFF voltage	VDD (V) \times 0.3 min. (1.35 V min. for VDD = 4.5 V; 1.5 V min. for VDD = 5 V; 1.65 V min. for VDD = 5.5 V)
Weight	Approx. 10 g	

Output

Item		B7AH-R6D53, B7AH-R6D58	
Output configuration		CMOS output	
I/O delay time		B7AH-R6D53: Normal speed (typical: 19.2 ms); B7AH-R6D58: High speed (typical: 3 ms)	
Current consumption (see note)		Logic circuit: 20 mA max.; Transmission circuit: 30 mA max.	
Output	Output voltage	H level	VDD (V) – 0.4 V min. (4.1 V min. for VDD = 4.5 V; 4.6 V min. for VDD = 5 V; 5.1 V min. for VDD = 5.5 V)
		L level	0.4 V max.
	Output current	H level	Sourcing current, 2 mA/point
		L level	Sinking current, 2 mA/point
Output logic		Active high (positive logic): N/P pins open Operation: Input ON → Output ON Input OFF → Output OFF Active low (negative logic): N/P pins connected to VDD (5 V) Operation: Input ON → Output OFF Input OFF → Output ON	
Error processing		LOAD OFF (output interrupted): H/L pins open HOLD (output held): H/L pins connected to VDD (5 V)	
Weight		Approx. 10 g	

Note: Consumption when all 16 points are ON. Excludes output current.

Operation

■ Noise and Miswiring Protection Circuits

Power supply noise protection circuit	SIG pin miswiring protection circuit	Input and output pin protection circuits
<p>Include the power supply noise protection circuit shown below if there is a possibility of noise interference between +V and –V (12 to 24-V power supply pins).</p>	<p>Include the circuit shown below if there is a possibility of miswiring between the SIG pin and the +V pin or VDD pin. (Connect to the SIG pin of B7AH input models.)</p>	<p>Include the circuit shown below if there is a possibility of noise or static electricity affecting input pins.</p>
<p>Include the power supply noise protection circuit shown below if there is a possibility of noise interference between VDD and VSS (5-V power supply pins).</p>		<p>Include the circuit shown below if there is a possibility of noise or static electricity affecting output pins.</p>

■ Power Supply

The B7AH is available in both normal-speed models and high-speed models. The recommended cable lengths and transmission distances are different for the 2 types. If a single power supply is connected to the Input or Output Link Terminal, (i.e., on the input side or output side), there are restrictions on the current that can flow along the power line.

I/O Delay: Normal Speed

Connection of Independent Power Supplies

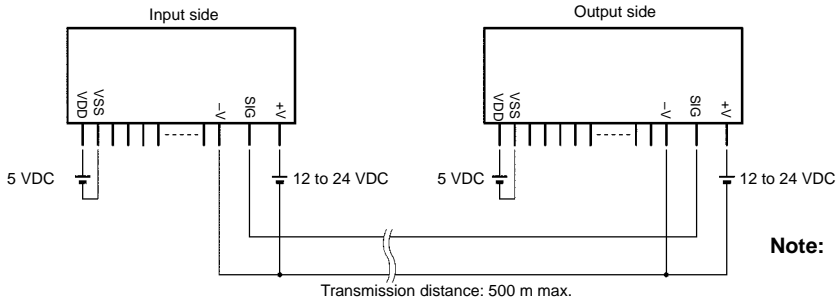

Note: A VCTF cable with a thickness of 0.75 mm² min. must be used for signal transmission.

Connection of Single Power Supply to Input or Output Terminal

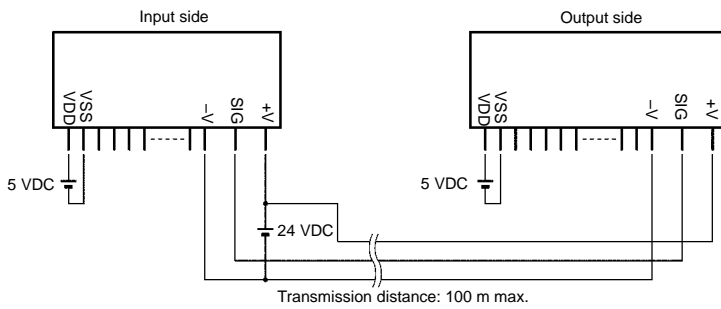

Note: A VCTF cable with a thickness of 0.75 mm² min. must be used for signal transmission. A current of 1.8 A max. can be transmitted along the power line (+, -).

I/O Delay: High Speed

Connection of Independent Power Supplies

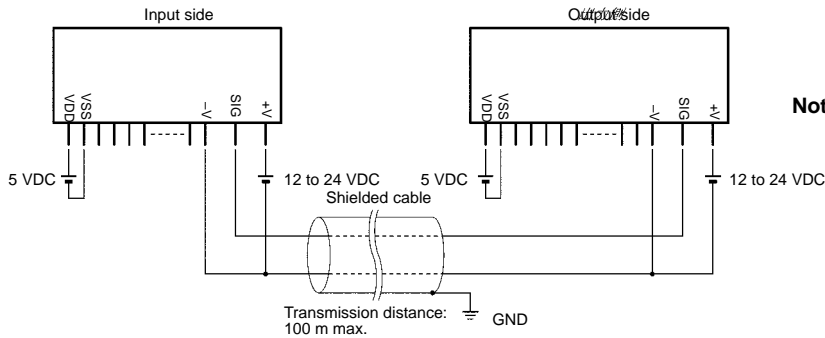

Note: In this example, a shielded cable with a thickness of 0.75 mm² min. is used for signal transmission. It is recommended that the shield be grounded. The maximum transmission distance is 10 m if a VCTF wire with a thickness of 0.75 mm² is used instead of a shielded cable for the transmission path.

Connection of Single Power Supply to Input or Output Terminal

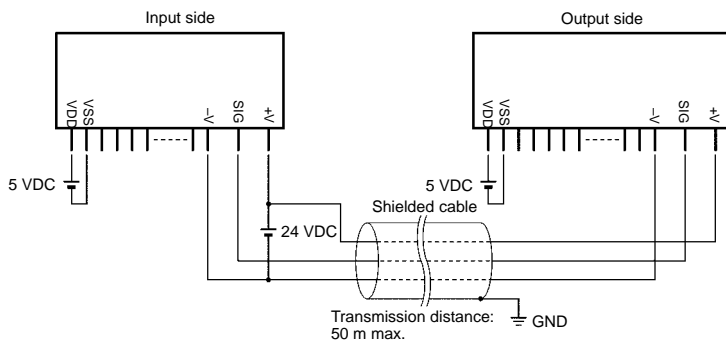

Note: In this example, a shielded cable with a thickness of 0.75 mm² min. is used for signal transmission. A current of 1.8 A max. can be transmitted through the power line (+, -). It is recommended that the shield be grounded. (Do not connect to a negative pin.) The maximum transmission distance is 10 m if a VCTF wire with a thickness of 0.75 mm² is used instead of a shielded cable for the transmission path.

Dimensions

Note: All units are in millimeters unless otherwise indicated.

Input Models B7AH-T6D3 B7AH-T6D8

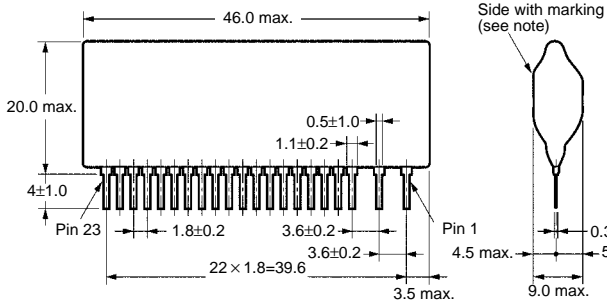

Note: The side with marking is at the front.

Output Models B7AH-R6D53 B7AH-R6D58

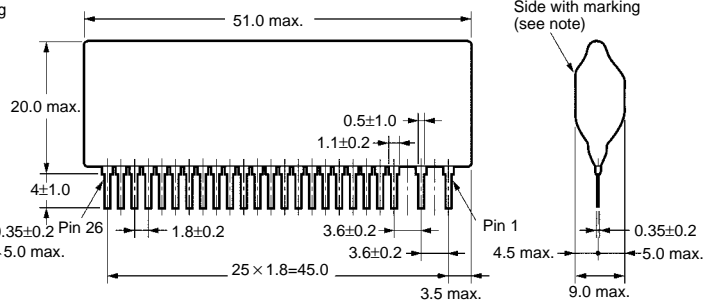

Note: The side with marking is at the front.

Installation

Pin Arrangement

Input Models

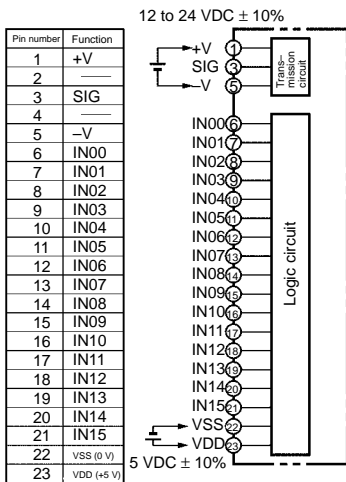
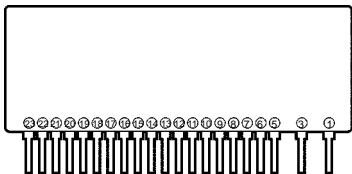

- Note:**
1. The circled numbers in the block diagram above are the pin numbers.
 2. There are no pin numbers 2 and 4.
 3. Pins 5 and 22 are connected internally.

Output Models

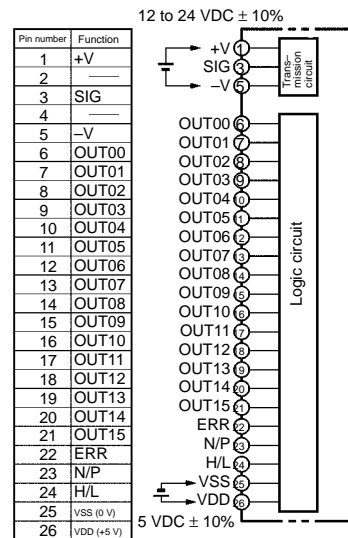
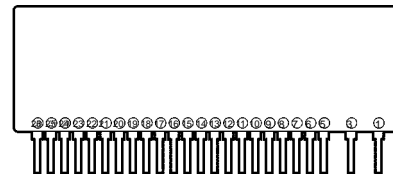

- Note:**
1. The circled numbers in the block diagram above are the pin numbers.
 2. There are no pin numbers 2 and 4.
 3. Pins 5 and 22 are connected internally.

Precautions

General

Common Precautions

The B7AH performs 1-to-1 communications and does not require a communications master. It cannot be connected to CompoBus/S transmission paths from OMRON remote masters.

Do not use the B7AH in locations subject to corrosive gases.

When using the B7AH in locations where a large amount of static electricity is generated (e.g., molding materials, powder, or fluid materials conveyed along pipelines), install the B7AH at least 1 m away from the source of the static electricity.

Line Resistance in the Transmission Path

If power and signals are transmitted together along 3-core cable, ensure that the line resistance in the transmission path between Link Terminals is less than 2.5 Ω. (The same value applies even if terminal blocks, connectors, or slip rings are used at points on the line.) If the line resistance rises to a value greater than this, the current flowing to 0 V and the line resistance will cause a large voltage drop, preventing normal transmission and generating an error. As a rough guide, the line resistance with a VCTF cable of thickness 0.75 mm² will be 2.5 Ω per 100 m.

Connection to 10-point B7A Terminals is not possible because transmission signals are not compatible.

If there is a possibility of shocks or vibration, prevent the pins being damaged by securing the Link Terminal to the PCB using an (e.g., epoxy-based) adhesive.

Do not touch the pins. Doing so may cause deformation. In addition, touching the pins in an ungrounded state may result in damage to internal elements due to static discharge. Use an anti-static mat during work to ensure that the body is in a grounded state.

Soldering

When soldering using a soldering iron or a soldering bath, solder in less than 5 s at a temperature not exceeding 260°C. Do not use reflow soldering.

■ Recommended Cables

Normal-speed Models

Cable Cables

With a single power supply connected to Input or Output Link Terminal:

0.75-mm² VCTF cable × 3

With independent power supplies connected:

0.75-mm² VCTF cable × 2

The following cables can also be used:

Twisted-pair Cables

(If only a single power supply is used, a conductor of thickness 0.75-mm² min. is required.)

Transmission distance: 100 m max.

High-speed Models

Shielded Cables

Use cables for which the cross-sectional area of the conductor is at least 0.75 mm².

Cleaning

Do not use highly acidic or highly alkaline solvents to clean the PCB.

Power Supply

Be sure to use the specified power supply voltage. Do not use a power supply that has a large ripple or intermittently generates abnormal voltages.

Noise and Miswiring Protection Circuits

If there is a possibility of noise interference between the power supply pins (+V and -V or VDD and VSS) or at input or output pins (IN00 to IN15 or OUT00 to OUT15), or if there is a possibility of miswiring the signal pin (SIG) and the positive power supply pin (+V or VDD), include the protection circuits described on page 68.

Wiring

Do not wire transmission lines parallel to, and less than 10 cm away from, lines carrying high voltages or currents. If transmission lines are installed less than 10 cm away from potential sources of noise, confirm that correct operation is possible before using the Link Terminal in actual operation.

Do not perform wiring with the power supply turned ON. Doing so may cause pins to be accidentally short-circuited, resulting in damage to internal elements and communications failure.

If the SIG pin and the positive power supply pin or the VDD (+5 V) pin are shorted during communications, the Link Terminal will malfunction and normal communications will not be possible. Confirm that power lines are not shorted before turning ON the power.

Be sure to apply the specified power supply to the power supply pins (positive, negative, VDD, and VSS). Applying excessive voltages (e.g., 100 VAC) will cause the Link Terminal to malfunction and normal communications will not be possible.

Shorting (no-load state) the OUT pins of Output Link Terminals during communications will cause the Link Terminal to malfunction. Be sure to connect a load within the specified load current range. When measuring the current with a tester, measure with the load supplied.

Water-resistive Transmission Unit

- Compact and satisfies the requirements of IP67.
- Incorporating an FA connector for limit switches, proximity sensors, and photoelectric sensors.
- Transmits 10 input signals.
- Incorporating easy-to-see indicators for I/O signal monitoring.



Ordering Information

■ Model Number Legend

B7AC - T 10 A 1 - A
 1 2 3 4 5 6

1. Classification

C: FA connector model

2. Input/Output Classification

T: Input

3. Number of I/O

10: 10 points

4. FA Connector/Contact Arrangement

A: M12/type A (Refer to page 79 for details.)

5. I/O Delay Time (Typical)

1: 19.2 ms

6. I/O Delay Selection (19.2 ms/3 ms)/Input Configuration

None: Without selection function/NPN

A: With selection function/NPN

B: With selection function/PNP

■ Product List

Refer to page 114 for details.

■ I/O Combinations

Refer to pages 1 to 5 for details.

■ Accessories (Attachment)

Name	Model	Material	Suitable connector	
			Model	Mounting part
Waterproof Cover	XS2Z-11	Aluminum/white	XS2G/XS2H/XS2M/XS2R	M12 male screw
	XS2Z-12		XS2C/XS2R/XS2F/XS2P	M12 female screw (with mounting bracket)
Dust Cover	XS2Z-13	Polyvinyl chloride/transparent	XS2G/XS2H/XS2M/XS2R	M12 male screw
	XS2Z-14	Polyvinyl chloride/red	XS2C/XS2R/XS2F/XS2P	M12 female screw (with mounting bracket)
	XS2Z-15			Contact block (female contact)

■ Suitable Connectors

Be sure to put the XS2Z-12 Waterproof Cover or XS2Z-15 Dust Cover on any unused connector.

For Input (Connector No. 0 to 9)

XS2G-D4□□	Assembling connector (crimp-style/solder-type/screw-type) plug
XS2H-D421-□□□	Cable with a connector (plug) at one end
XS2W-D42□-□□□	Cable with connectors at both ends (socket and plug)

For Transmission Path and Power Supply Line (Connector No. P)

XS2C-D4□□	Assembling connector (crimp-style/solder-type/screw-type) socket
XS2F-D42□-□80	Cable with a connector at one end (socket)

Specifications

■ Characteristics

General

Communications method	Unidirectional, time-division multiplex
Transmission distance	100 m max.
I/O delay time	Typical: 19.2 ms; 31 ms max.
Minimum input time (see note)	16 ms
Operating voltage range	24 VDC (21.6 to 26.4 VDC)
Insulation resistance	100 M Ω min. (500 V) between each terminal and external parts
Dielectric strength	1,000 VAC, 50/60 Hz for 1 min between each terminal and external parts
Noise immunity	Noise level: 1.5 kV; pulse width: 100 ns to 1 μ s (on transmission line due to coupling)
Vibration resistance	10 to 55 Hz, 1.5-mm double amplitude
Shock resistance	300 m/s ²
Ambient temperature	Operating: -10 to 55°C (with no icing) Storage: -25 to 65°C (with no icing)
Ambient humidity	Operating: 35% to 85% (with no condensation)
Enclosure rating	IEC IP67
Weight	Approx. 420 g

Note: The minimum input time is required for the B7AC to read an input signal.

Enclosure Rating

- Do not continuously impose external force on the joint of the contact block and cover, otherwise IP67 may not be maintained.
- IP67 does not ensure that the B7AC is perfectly watertight. Do not use the B7AC underwater.
- The case of the B7AC is made of plastic resin. Do not put heavy objects on it.

B7AC-T10A1/B7AC-T10A1-A Input

Compatible inputs	Switches, two-wire sensors, three-wire NPN sensors
Input logic	Active low
Current consumption (see note)	120 mA max. with all input terminals ON
Input voltage range	0 VDC to supply voltage
Input current range	-5.3 to -3.6 mA/point
ON/OFF threshold	No-contact input: ON voltage: 5.5 V max. OFF voltage: 7.5 V min. Contact input: ON discrimination resistance: 1 k Ω max. OFF discrimination resistance: 2.1 k Ω min.

Note: Consumption when all 10 points are ON. Excludes external sensor current for Input Terminals.

B7AC-T10A1-B Input

Compatible inputs	Switches, two-wire sensors, three-wire PNP sensors
Input logic	Active high
Current consumption (see note)	120 mA max. with all input terminals ON
Input voltage range	0 VDC to supply voltage
Input current range	3.6 to 5.3 mA/point
ON/OFF threshold	No-contact input: ON voltage: Power supply voltage –5.5 V min. OFF voltage: Power supply voltage –7.5 V max. Contact input: ON discrimination resistance: 1 kΩ max. OFF discrimination resistance: 2.1 kΩ min.

Note: Consumption when all 10 points are ON. Excludes external sensor current for Input Terminals.

Nomenclature

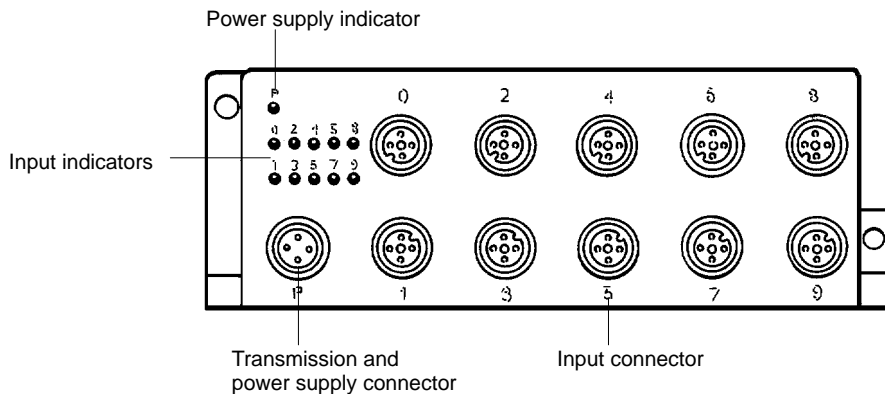

Indicator Operation

Indicator	Function
POWER	G Lit when power is supplied and the Terminal is operating.
	N Not lit when power is not supplied.
Input	O Lit when the input signals are ON.
	N Not lit when the signals are OFF.

Note: G: Green indicator lit; O: Orange indicator lit; N: Not lit

Operation

■ System Configuration

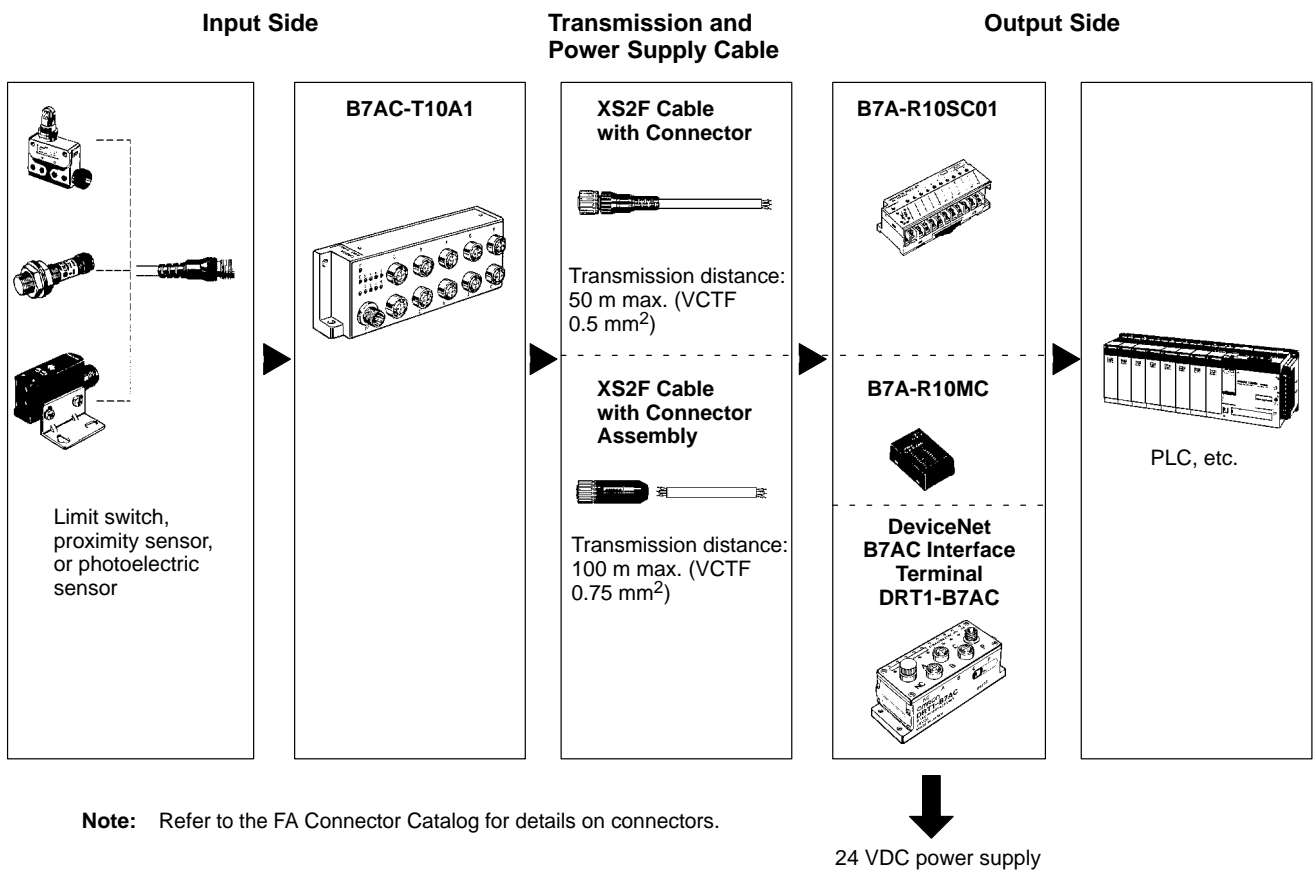

■ Connecting Input Devices

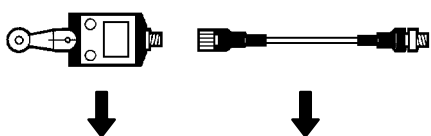
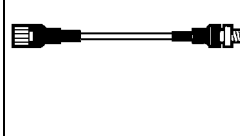
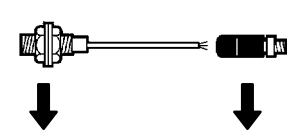
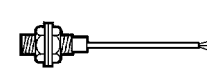
Input Devices		Direct connection		Joint connection	Pre-wired	Pre-wired
						
B7AC-T10A1, B7AC-T10A1-A	Limit switch	WL□-□K13 D4E-□□10N (see note)	XS2W-D42□-□81-A	WL□-□DK1EJ□ D4C-□0□□DK1EJ□ (see note)	Refer to the following conditions required for connectable input devices.	XS2G
	Proximity sensor	E2E-X2E1-P1 E2E-X5ME1-P1 E2E-X5E1-P1 E2E-X10ME1-P1 E2E-X10E1-P1 E2E-X18ME1-P1		E2E-X3D1-M1J-T E2E-X7D1-M1J-T E2E-X10D1-M1J-T		
	Photoelectric sensor	E3S-AT16 E3S-AT66 E3S-AD16 E3S-AD17 E3S-AD66 E3S-AD67 E3S-AR16 E3S-AR66		E3S-AT11-M1J E3S-AT61-M1J		
B7AC-T10A1-B	Limit switch	D4CC		WL□-□M1GJ D4C-□0□□M1GJ		
	Proximity sensor	E2E-X2E1-M1 E2E-X5ME1-M1 E2E-X5E1-M1 E2E-X10ME1-M1 E2E-X10E1-M1 E2E-X18ME1-M1		E2E-X3D1-M1GJ-T E2E-X7D1-M1GJ-T E2E-X10D1-M1GJ-T		
	Photoelectric sensor	E3S-AT36 E3S-AT86 E3S-AD36 E3S-AD37 E3S-AD86 E3S-AD87 E3S-AR36 E3S-AR86		E3S-AT31-M1GJ E3S-AT81-M1GJ		

Note: Normally open connection is possible with the limit switches listed in the above table.

Input Device Connection Conditions

Two-wire DC Sensor

Residual voltage: 5 V max.
Leakage current: 1.5 mA max.
Lower limit of control output: 3 mA max.

Three-wire NPN Sensor

Residual voltage: 5 V max.

Contact Switch

Leakage current: 1.5 mA max.

■ Power Supply

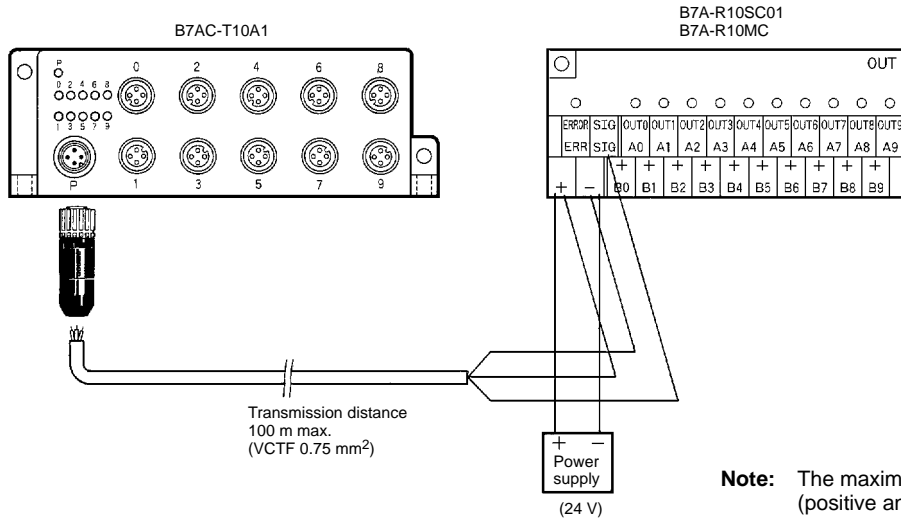

Dimensions

Note: All units are in millimeters unless otherwise indicated.

B7AC-T10A1

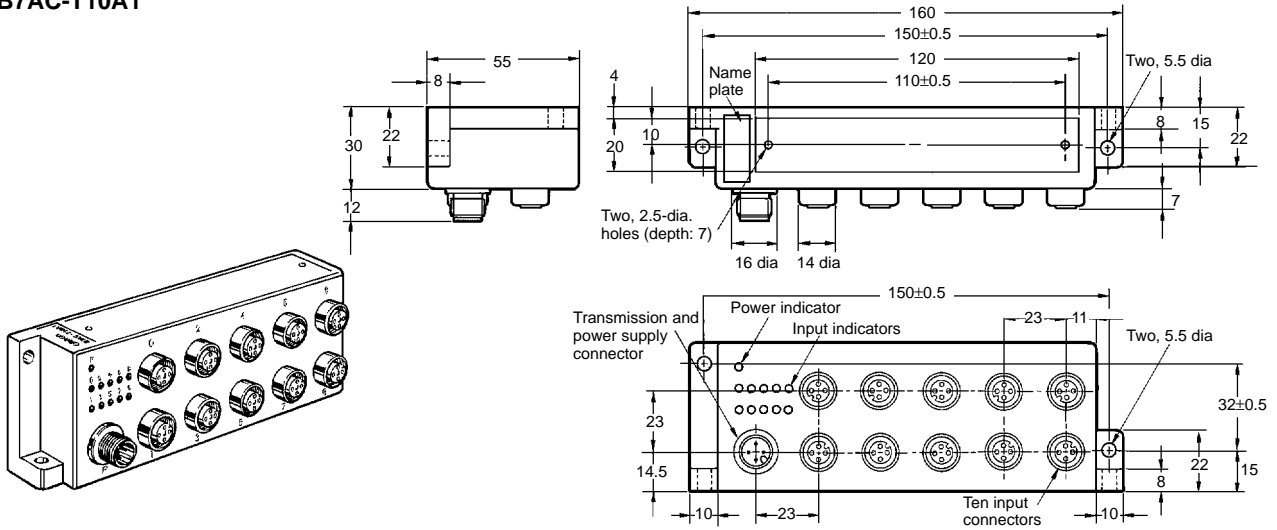

Waterproof Cover

XS2Z-11

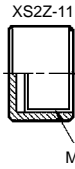
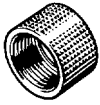

⇒ Transmission and power supply connector

XS2Z-12

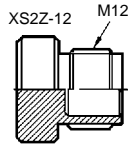

⇒ Input connector

Note: The B7AC maintains IP67 with the XS2Z-11 and XS2Z-12 Waterproof Covers. Be sure to connect the XS2Z-11 and XS2Z-12 Waterproof Covers to the connectors by hand and tighten the Waterproof Covers securely with a force of 4 to 5 kgf • cm (0.39 to 0.49 N • m).

Dust Cover

XS2Z-13

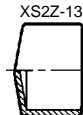

⇒ Transmission and power supply connector

XS2Z-14/XS2Z-15

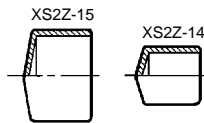

⇒ Input connector

Note: The XS2Z-13, XS2Z-14, and XS2Z-15 Dust Covers are used for dust prevention. The B7AC cannot maintain IP67 with them. Press them securely to the connector joints.

Installation

Internal Circuit

B7AC-T10A1/B7AC-T10A1-A

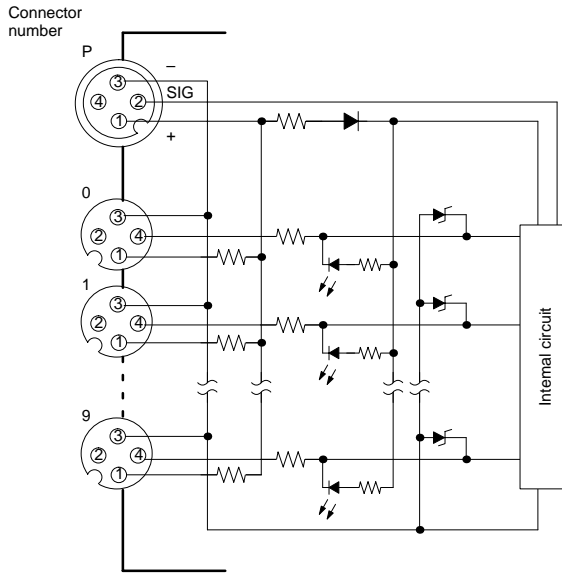

Connector No. 0 to 9 (Input)

With Contact Switch

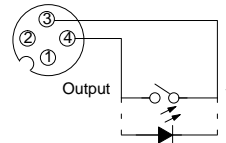

Note: The permissible current leakage is 1.5 mA max.

With Two-wire DC Sensor

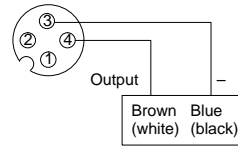

Note: The contact arrangement of the two-wire DC sensor does not conform to NECA 4202.

With Three-wire NPN Sensor

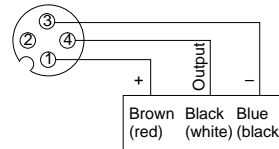

Note: The contact arrangement of the three-wire NPN sensor corresponds to the normally open output contact of the three-wire DC sensor of NECA 4202.

Connector No. P (Transmission)

Connection to B7A Output Unit

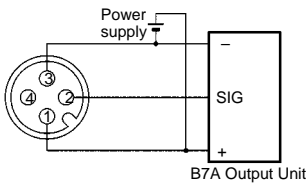

Note: No connection is required to the I/O delay selection terminal (terminal 4).

Connection to DRT1-B7AC

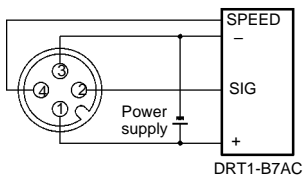

Note: The I/O delay time can be selected by connecting to the I/O delay selection terminal (terminal 4). Selection is made using the DRT1-B7AC's selection switch.

B7AC-T10A1-B

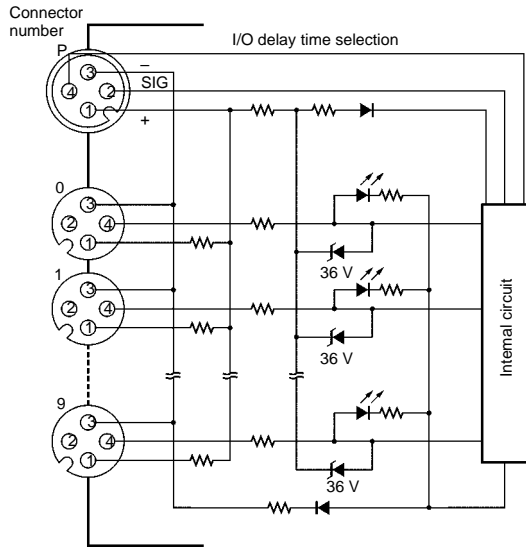

Note: Terminal 2 of connector numbers 0 to 9 is not used.

Connector No. 0 to 9 (Input)

With Contact Switch

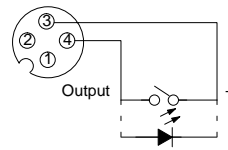

With Two-wire DC Sensor

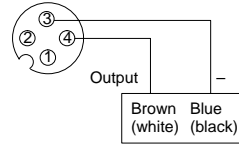

With Three-wire PNP Sensor

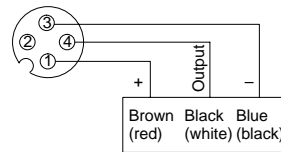

Connector No. P (Transmission)

Connection to B7A Output Unit

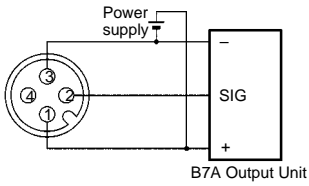

Note: No connection is required to the I/O delay selection terminal (terminal 4).

Connection to DRT1-B7AC

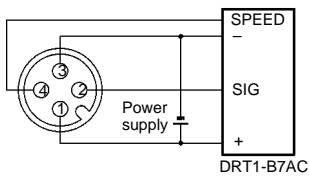

Note: The I/O delay time can be selected by connecting to the I/O delay selection terminal (terminal 4). Selection is made using the DRT1-B7AC's selection switch.

An Interface Terminal that Groups Link Terminals with Sensor I/O Connectors (10 Input Points × 3) and Enables Connection to DeviceNet

- Branching to 3 B7AC Link Terminals possible with just a single Unit.
- Connectors eliminate the need for mounting accessories.
- High environment resistance achieved with dust-tight, drip-proof structure (IP66).
- Compact dimensions: 135 × 51 × 56 mm (W × D × H).



Ordering Information

■ Product List

Name	Number of ports	I/O connection configuration	Number of I/O points	Model
B7AC Interface Terminal	3	FA connector	3 sets of 10	DRT1-B7AC

■ Applicable Connectors

For Transmission Path (Connector No. P)

XS2G-D4□□	Assembling connector (crimp-style/solder-type/screw-type) plug
XS2H-D421-□□□	Cable with a connector (plug) at one end
XS2W-D42□-□□□	Cable with connectors at both ends (socket and plug)

For Power Supply Line (Connector No. P)

XS2C-D4□□	Assembling connector (crimp-style/solder-type/screw-type) socket
XS2F-D42□-□80	Cable with a connector at one end (socket)

■ DeviceNet Connecting Cables

DCA1-5CN□□W1	Cable with connectors at both ends
DCA1-5CN□□F1	Cable with a connector (socket) at one end
DCA1-5CN□□H1	Cable with a connector (plug) at one end

■ DeviceNet T-branch Connectors

DCN2-1	Shielded T-branch connector
--------	-----------------------------

■ Terminating Resistors

DRS2-1	Plug-type terminating resistor
DRS2-2	Socket-type terminating resistor

Application Examples

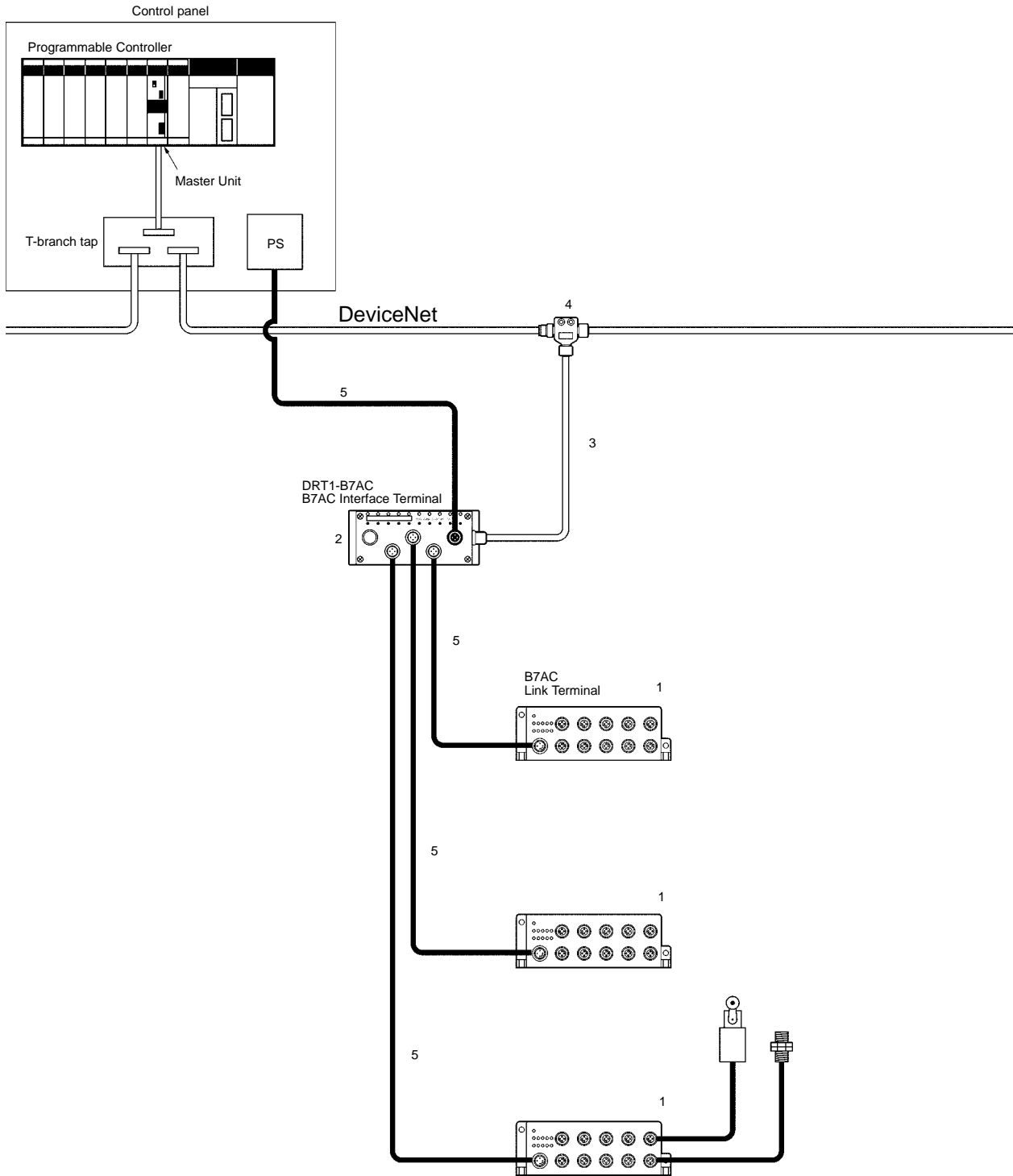

No.	Classification
1	B7AC Link Terminal
2	B7AC DeviceNet Interface Terminal
3	DeviceNet Connecting Cable (DCA1)
4	DeviceNet T-branch Connector (DCN2-1)
5	Connecting Cable (X2SW)

Specifications

■ Characteristics

General

Communications power supply voltage	11.0 to 25.0 VDC (supplied from the communications connector)
External power supply voltage	24 VDC $+10\%/_{-15\%}$
Current consumption	Interface Terminal power supply: 500 mA max. (with B7AC input OFF)
Dielectric strength	500 VAC for 1 minute (between isolated circuits; detection current: 1 mA)
Noise immunity	Power supply normal for internal circuits: ± 600 V for 10 minutes; pulse width: 100 ns to 1 μ s Power supply common for internal circuits: ± 1.5 kV for 10 minutes; pulse width: 100 ns to 1 μ s
Vibration resistance	Malfunction: 0.5-mm single amplitude, 10 to 150 kHz, 70 m/s ² Destruction: 0.75-mm single amplitude, 10 to 150 kHz, 100 m/s ²
Shock resistance	Malfunction: 200 m/s ² Destruction: 300 m/s ²
Ambient temperature	Operating: -10 to 55°C Storage: -25 to 65°C
Ambient humidity	Operating: 25% to 85% (with no condensation)
Ambient atmosphere	No corrosive gases present
Enclosure rating	IEC IP66
Mounting method	M5-screw mounting
Mounting strength	100 N, 10 s
Connector strength	Pulling force: 100 N, 10 s
Weight	500 g max.
Dimensions	135 × 51 × 56 (W × D × H)

■ Communications Specifications

Conformance with DeviceNet

Communications method	CSMA/NBA			
Maximum number of connecting nodes	64 max. (including the master) The maximum number of slaves that can be connected to the network is 63.			
Connection format	Multi-drop, T-branching (main lines/branch lines), and branching (branch lines)			
Baud rate	125 Kbps/250 Kbps/500 Kbps (switchable)			
Communications distance	Baud rate	Max. network length	Branch line length	Total branch line length
	500 Kbps	100 m max.	6 m max.	39 m max.
	250 Kbps	250 m max.	6 m max.	78 m max.
	125 Kbps	500 m max.	6 m max.	156 m max.
Length of data packets	0 to 8 bytes			
Cables	Cables conforming to DeviceNet standards (2 signal lines; 2 power supply lines; 2; 1 shield line)			

B7A

Communications method	Unidirectional, time-division multiplex
Transmission distance	50 m max. (normal speed); 30 m max. (high speed)
I/O delay time (see note)	High speed: 3 ms, 5 ms max. (typical) Normal speed: 19.2 ms, 31 ms max. (typical)
Number of ports	3 ports
I/O connection format	FA connector
Number of I/O points	30 points (10 × 3 ports)

Note: The I/O delay time is selected with a DIP switch.

Nomenclature

DRT1-B7AC

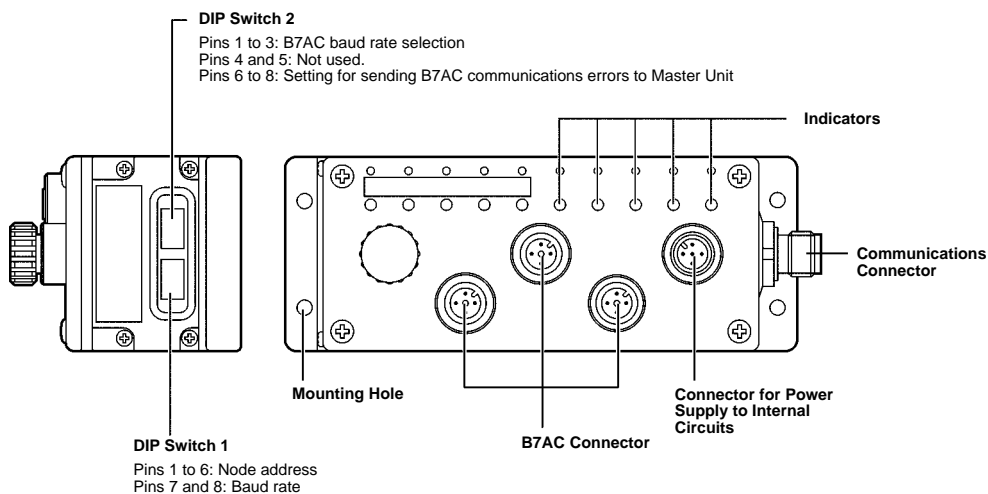

Dimensions

Note: All units are in millimeters unless otherwise indicated.

DRT1-B7AC

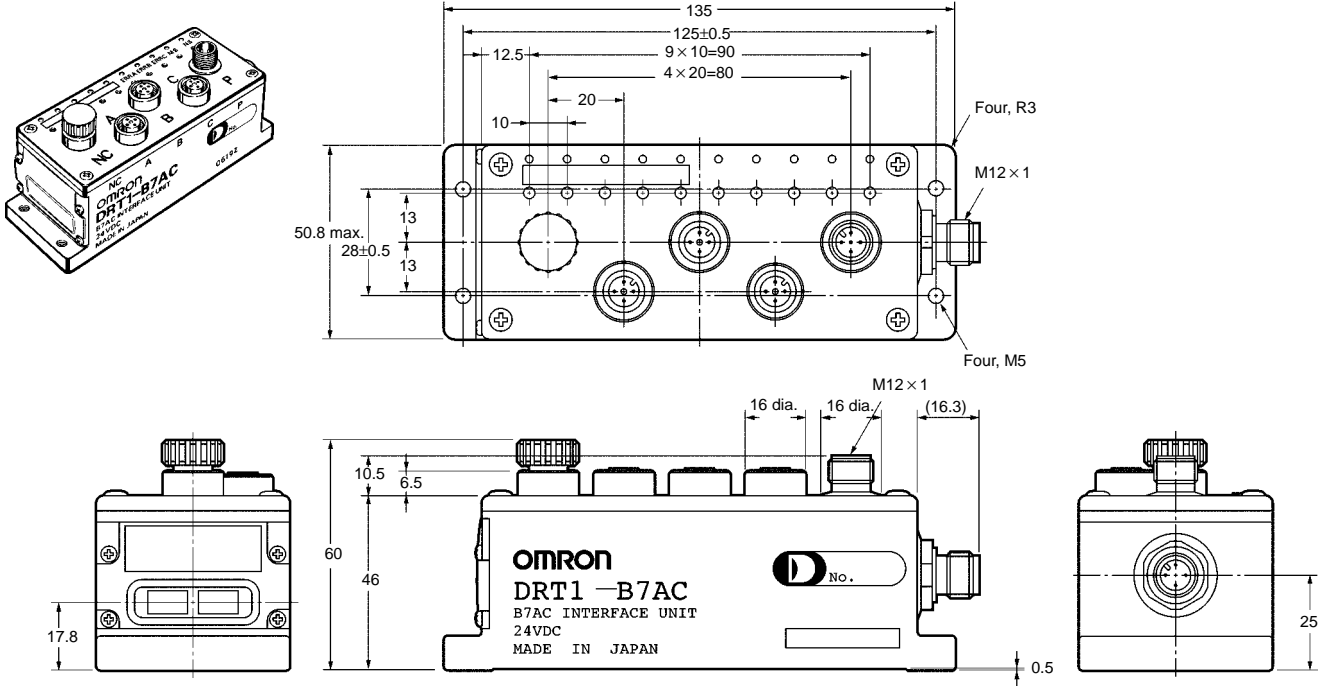

Transmit Signals while Saving Space and Wiring Effort

- More economical than previous multipoint transmission terminals.
- Transmit 10 input signals over just 2 wires (or over 3 wires if one terminal has power supply).
- Models available with either screw terminals or modular terminals.
- Indicators provided on models with screw terminals for easy visual confirmation of I/O signal status.
- Three-wire NPN output sensor can be connected to the B7A with screw terminals (two-wire proximity sensors cannot be connected).



Ordering Information

■ Model Number Legend

Input Models

B7A - T 10 □ □
 1 2 3 4

1. Input/Output Classification

T: Input

2. Number of I/O

10: 10

3. Appearance

S: Screw terminals

M: Module

4. Input Logic

4	Input logic	Internal I/O common	Remarks
1	NPN compatible	- common	Screw terminals only
2	TTL	---	Module only
3	NPN compatible	+/- common	Screw terminals only

Output Models

B7A - R 10 □ C □
 1 2 3 4 5

1. Input/Output Classification

R: Output

2. Number of I/O

10: 10

3. Appearance

S: Screw terminals

M: Module

4. Output Logic

4	Output logic	Internal I/O common	Remarks
C	NPN open collector	+ common	Screw terminals only
		---	Module only

5. Output Capacity

5	Output capacity	Remarks
None	0.05 A	Module only
01	0.1 A	Screw terminals only

■ Product List

Refer to page 114 for details.

■ I/O Combinations

Refer to pages 1 to 5 for details.

Specifications

■ Characteristics

General

Item	Normal speed
Communications method	Unidirectional, time-division multiplex
Transmission distance (see note 1)	500 m max.
I/O delay time	Typical: 19.2 ms; 31 ms max.
Minimum input time (see note 2)	16 ms
Operating voltage range	12 to 24 VDC (10.8 to 26.4 VDC) (see note 1)
Insulation resistance	100 MΩ min. (500 V) between each terminal and external parts
Dielectric strength	1,000 VAC, 50/60 Hz for 1 min between each terminal and external parts
Noise immunity	Noise level: 1.5 kV; pulse width: 100 ns to 1 μs (on transmission line due to coupling)
Vibration resistance	10 to 55 Hz, 1.5-mm double amplitude
Shock resistance	300 m/s ²
Ambient temperature	Operating: -10 to 55°C (with no icing) Storage: -25 to 65°C (with no icing)
Ambient humidity	Operating: 35% to 85% (with no condensation)

Note: 1. The transmission distance values stated in this table are possible if the Input or Output Link Terminal is connected to an independent power supply. If a single power supply is connected to the Input or Output Link Terminal, the supply voltage must be 24 VDC ±10%, in which case the transmission distance is 100 m maximum. Refer to *Power Supply* on page 89 for details.

2. The minimum input time is required for the B7A to read an input signal.

Input Models

Item	Screw terminal models		Modular models
	B7A-T10S1	B7A-T10S3	B7A-T10M2
Compatible inputs	Switches, three-wire NPN sensors (see note 1)		TTLs, switches
Input logic	Active low		Active high
Current consumption (see note 2)	80 mA max. with all input terminals ON		40 mA max. with all input terminals ON
Input voltage range	0 VDC to supply voltage		0 to 5 VDC ±10%
Operating voltage range	12 to 24 VDC		
Input current range	-4.4 to -1.1 mA/point (current flowing from input terminals)		1.7 to 2.2 mA/point
Minimum input time (see note 3)	16 ms		
ON/OFF threshold	No-contact input: ON voltage: 1.6 V max. OFF voltage: 5.5 V min. Contact input: ON discrimination resistance: 140 Ω max. OFF discrimination resistance: 5 kΩ min.		ON voltage: 2.2 V min. OFF voltage: 0.8 V max.
Mounting strength	No damage when 49-N pull is applied for 1 min each in all directions (except direction of DIN track)		---
Terminal strength	No damage when 49-N pull is applied for 1 min each in all directions		---
Tightening torque	0.78 to 1.18 N • m		---
Weight	Approx. 100 g		Approx. 12 g

Note: 1. The polarity of the B7A-TS10S1's B□ terminal is negative. Therefore, supply power to the three-wire sensor from the positive power supply terminal or a power supply.

2. Consumption when all 10 points are ON. Excludes external sensor current for Input Terminals.

3. The minimum input time is required for the B7A to read an input signal.

Output Models

Item	Screw terminal models	Modular models
	B7A-R10SC01	B7A-R10MC
Output configuration	NPN open collector	
Current consumption (see note 1)	80 mA max. with all output terminals ON	40 mA max. with all output terminals ON
Operating voltage range	12 to 24 VDC	
Rated load voltage	5 to 24 VDC	
Output residual voltage	0.8 V max.	
Output current	Sync. current, 100 mA max./point	Sync. current, 50 mA max./point
Error processing	HOLD	
Mounting strength	No damage when 49-N pull is applied for 1 min each in all directions (except in direction of DIN track)	---
Terminal strength	No damage when 49-N pull is applied for 1 min each in all directions	---
Tightening torque	0.78 to 1.18 N • m	
Output logic (see note 2)	---	Active high (N/P terminals open) Active low (N/P terminals connected to 0 V)
Weight	Approx. 110 g	Approx. 21 g

Note: 1. Consumption when all 10 points are ON. Excludes external load current and error load current for Output Terminals.
 2. Refer to *I/O Status* on page 102 for the relationship between the output logic and output ON/OFF status of the B7A.

Nomenclature

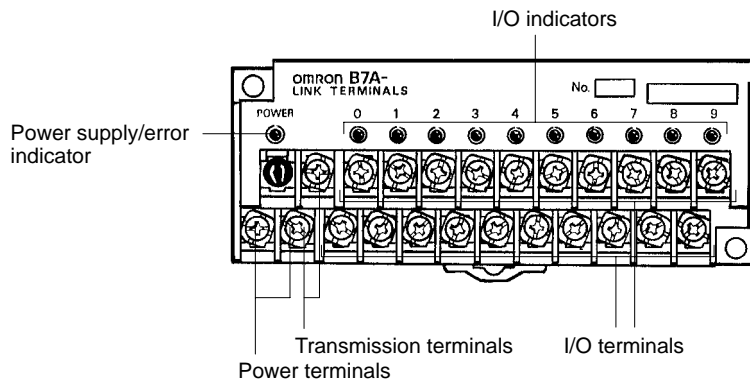

Indicator Operation

Indicator		Function
POWER (Input Terminal)	G	Lit when power is supplied and the Terminal is operating.
	N	Not lit when power is not supplied.
POWER/ERR (Output Terminal)	G	Lit when power is supplied and the Terminal is operating without error.
	R	Lit during transmission errors.
	N	Not lit when power is not supplied.
I/O	O	Lit when the input signals are ON.
	N	Not lit when the signals are OFF.

Note: G: Green indicator lit; R: Red indicator lit; O: Orange indicator lit; N: Not lit

Recommended Solderless Terminals

Wire	JIS specifications
0.75 mm ² (AWG#18)	RAV 1.25 to 3.5 (vinyl-insulated round wire) or RAP 1.25 to 3.5
1.25 mm ² (AWG#16)	(nylon-insulated round wire)

Operation

Power Supply Screw Terminal Models

Connection of Independent Power Supplies

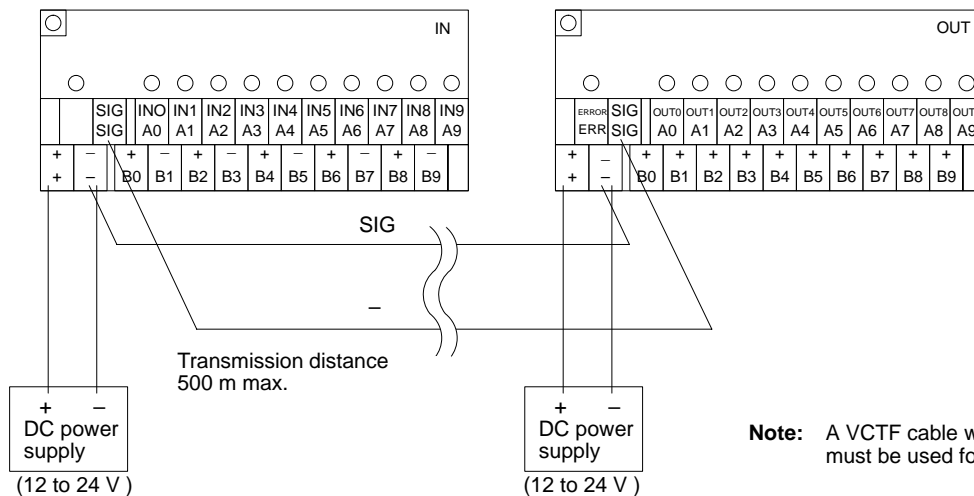

Connection of Single Power Supply to Input or Output Terminal

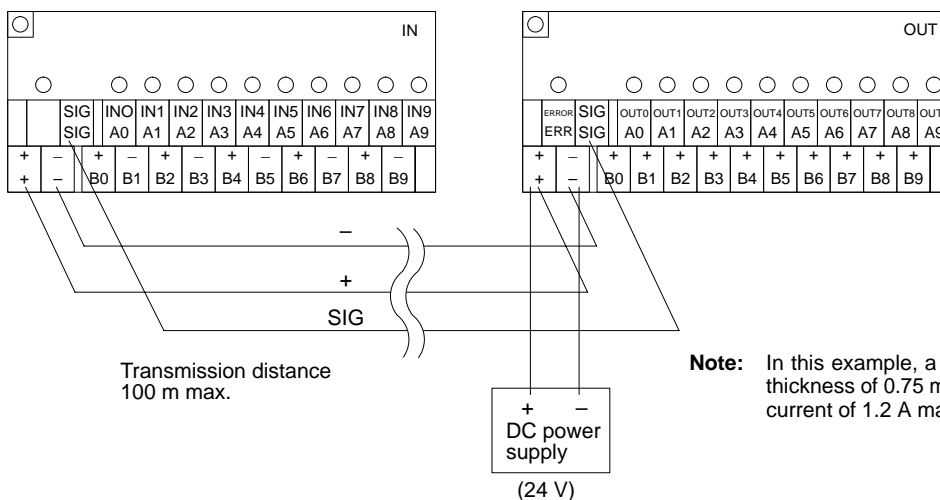

Modular Models

Connection of Independent Power Supplies

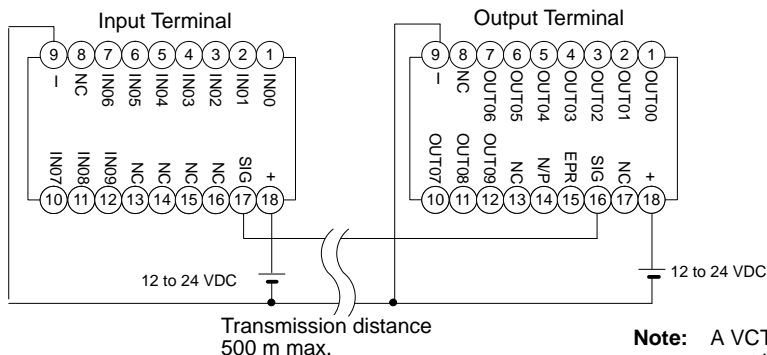

Connection of Single Power Supply to Input or Output Terminal

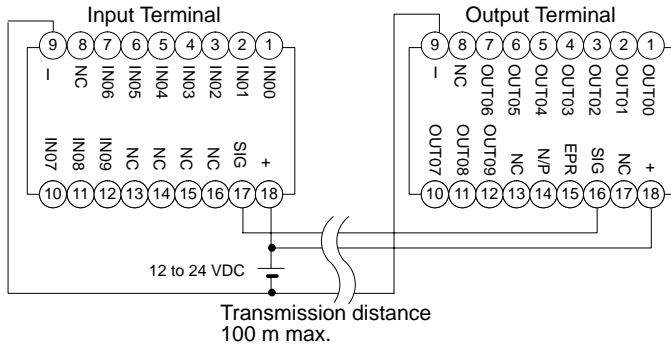

Note: In this example, a VCTF transmission cable with a thickness of 0.75 mm² min. is used, through which a current of 1.2 A max. can be transmitted.

Dimensions

Note: All units are in millimeters unless otherwise indicated.

Screw Terminal Models

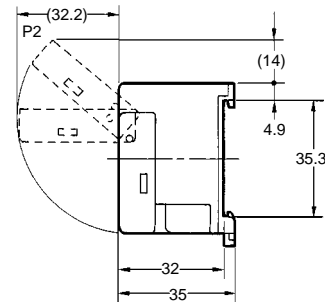
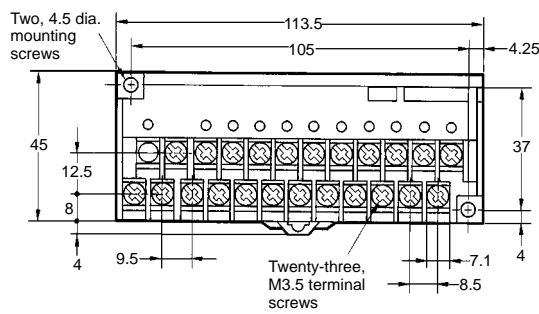
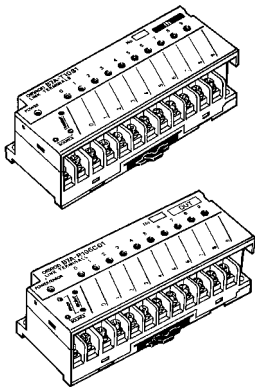

Modular Models

B7A-T10M2 (Input)

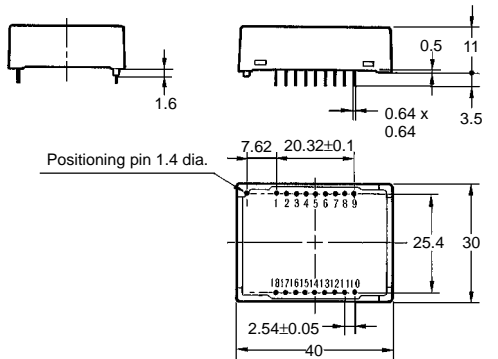

B7A-R10MC (Output)

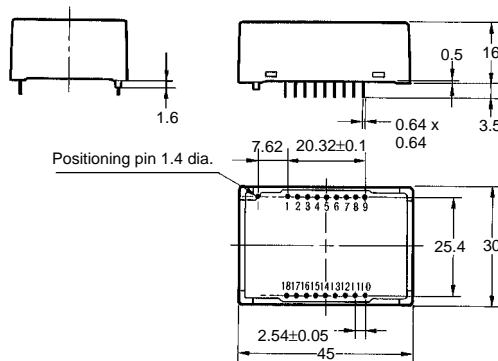

Mounting Holes (Top View)

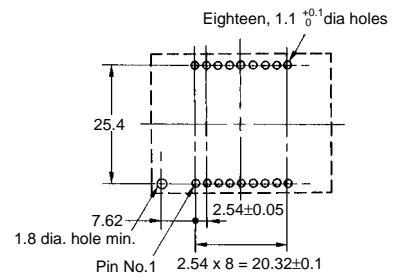

Installation

Internal Circuits and Terminal Arrangement

Screw Terminal Models

B7A-T10S1
(Input, Active Low)

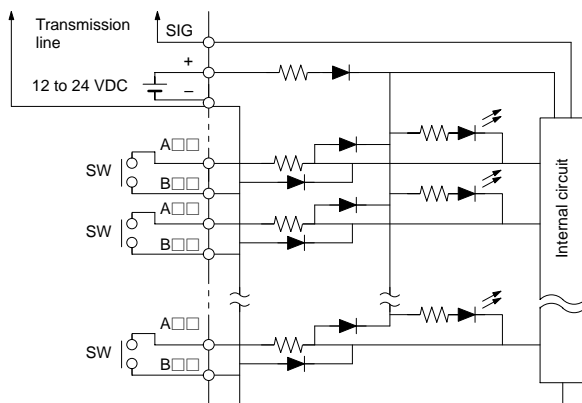

Note: A sensor with two-wire output cannot be connected.

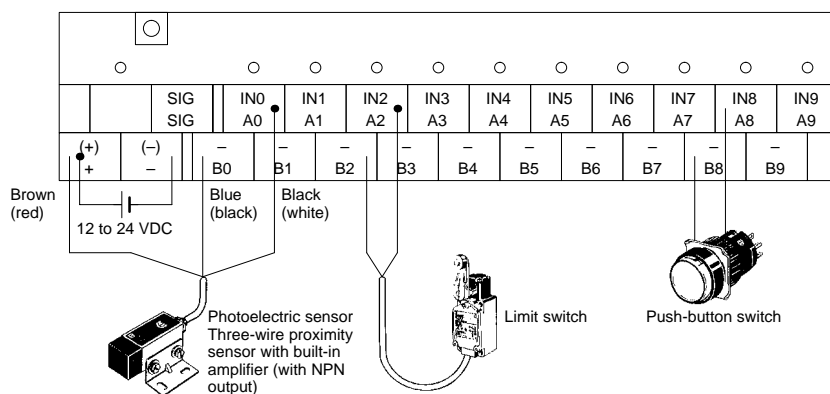

B7A-T10S3
(Input, Active Low for NPN 3-wire Sensor)

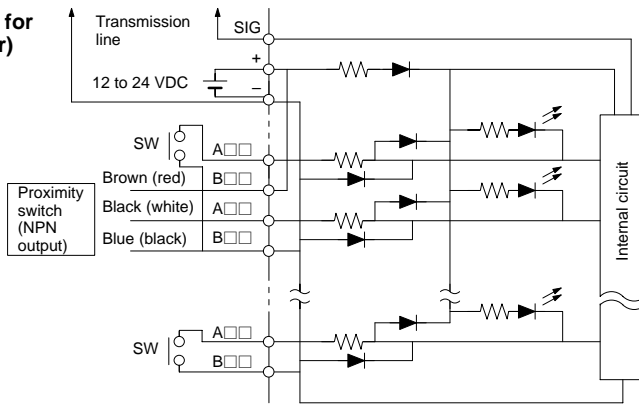

- Note:**
1. A sensor with two-wire output cannot be connected.
 2. The wire colors have been changed in accordance with the revision of the Japanese Industrial Standards for photoelectric sensors and proximity sensors. The colors in parentheses refer to the old colors.
 3. Do not short-circuit the SIG terminal with the positive power supply terminal, negative power supply terminal, or a B□□ terminal, otherwise the internal elements of the B7A will be damaged and no transmission will be possible.

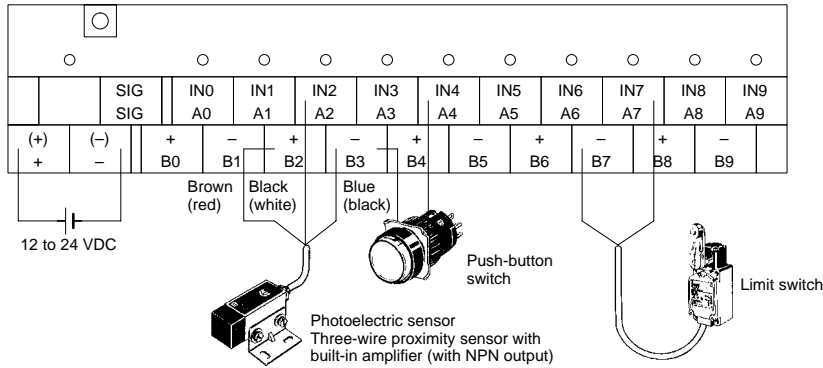

B7A-R10SC01
(Output, NPN Open Collector)

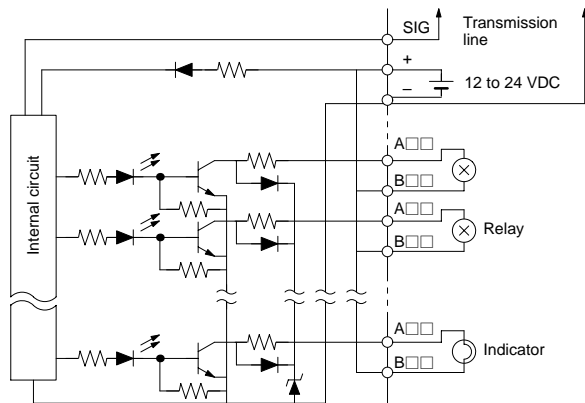

- Note:** Do not short-circuit any output A terminal with the corresponding B terminal, otherwise the internal elements of the B7A will be damaged.

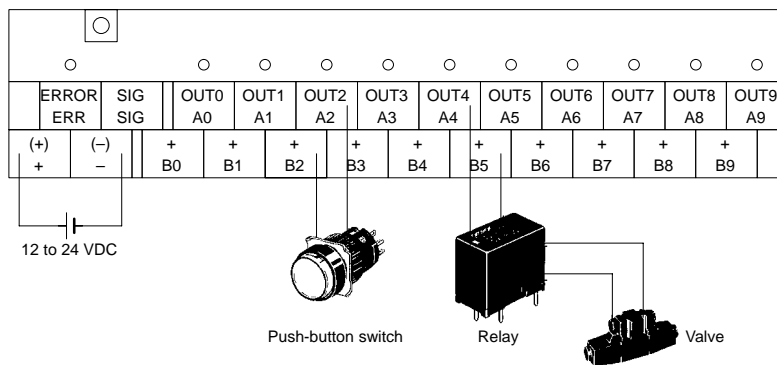

Modular Models

B7A-T10M2 (Input, Active High for TTL)

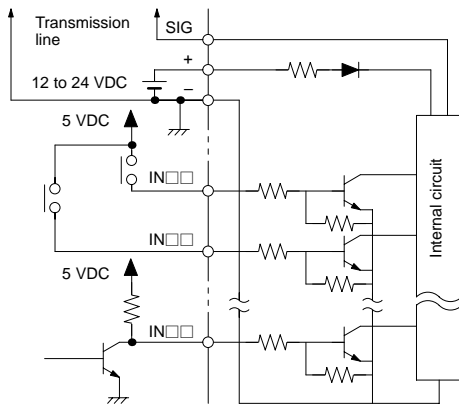

Top View

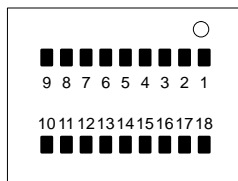

Note: Do not short-circuit the SIG terminal with the positive power supply terminal, negative power supply terminal, otherwise the internal elements of the B7A will be damaged and no transmission will be possible.

No.	Terminal
1	IN00
2	IN01
3	IN02
4	IN03
5	IN04
6	IN05
7	IN06
8	NC
9	-
10	IN07
11	IN08
12	IN09
13	NC
14	NC
15	NC
16	NC
17	SIG
18	+

B7A-R10MC (Output, NPN Open Collector)

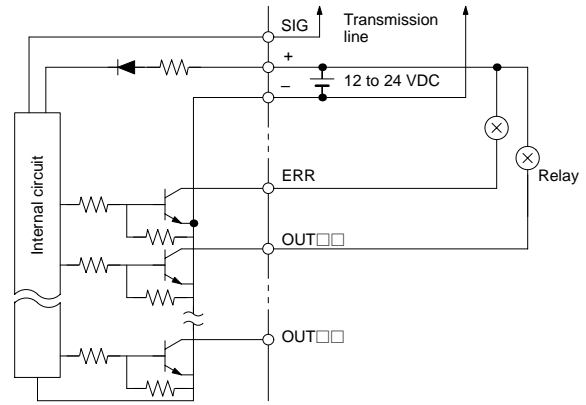

Top View

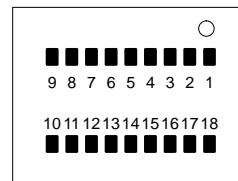

Note: Do not short-circuit any output A terminal with the corresponding B terminal, otherwise the internal elements of the B7A will be damaged.

No.	Terminal
1	OUT00
2	OUT01
3	OUT02
4	OUT03
5	OUT04
6	OUT05
7	OUT06
8	NC
9	-
10	OUT07
11	OUT08
12	OUT09
13	NC
14	N/P
15	ERR
16	SIG
17	NC
18	+

Ideal for reducing wiring between compact CQM1/CQM1H PLCs and I/O devices installed up to 500 m away

- Mount like any other PLC Unit to reduce wiring and save space.
- Select from the following 5 types according to the number of I/O points required: models with 16 inputs, 16 outputs, 32 inputs, 32 outputs, or 16 inputs and 16 outputs.
- Use like an I/O Unit to connect the CPU Unit to I/O devices such as switches and lamps in remote locations. No special consideration of communications is required.
- Both normal I/O delay and short I/O delay available with each model.

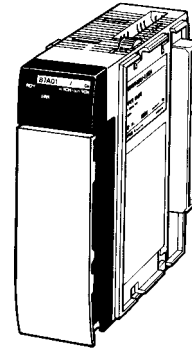

Ordering Information

■ Connectable B7A Link Terminals

Input Models

Type	Model	I/O delay time
Screw terminal models	B7A-T6□1	Normal speed: 19.2 ms
	B7AS-T6□1	
	B7A-T6□6	High speed: 3 ms
	B7AS-T6□6	
	B7AS-T3BS	Switchable
	B7AM-6BS	
Modular models	B7A-T6D2	Normal speed: 19.2 ms
	B7A-T6D7	High speed: 3 ms
Hybrid IC models	B7AH-T6D3	Normal speed: 19.2 ms
	B7AH-T6D8	High speed: 3 ms
PLC connector models	B7A-T6E3	Normal speed: 19.2 ms
	B7A-T6E8	High speed: 3 ms
	B7A-T3E3	Normal speed: 19.2 ms
	B7A-T3E8	High speed: 3 ms

Output Models

Type	Model	I/O delay time
Screw terminal models	B7A-R6□□1	Normal speed: 19.2 ms
	B7AS-R6□□1	
	B7A-R6□□6	High speed: 3 ms
	B7AS-R6□□6	
	B7AM-6BS	Switchable
	G70D-R6R□1-B7A	Normal speed: 19.2 ms
G70D-R6M□1-B7A		
Modular models	B7A-R6A52	Normal speed: 19.2 ms
	B7A-R6A57	High speed: 3 ms
Hybrid IC models	B7AH-R6D53	Normal speed: 19.2 ms
	B7AH-R6D58	High speed: 3 ms
PLC connector models	B7A-R6A□3	Normal speed: 19.2 ms
	B7A-R6A□8	High speed: 3 ms
	B7A-R3A□3	Normal speed: 19.2 ms
	B7A-R3A□8	High speed: 3 ms

Note: Use combinations of B7A Interface Units and B7A Link Terminals that have the same I/O delay time. Connection is not possible for 10-point B7A Link Terminals.

Specifications

■ Characteristics

General

Item	CQM1-B7A12	CQM1-B7A13	CQM1-B7A02	CQM1-B7A03	CQM1-B7A21
Number of I/O points	16 inputs Input (reception): 16 points or 15 points and 1 error input	32 inputs Input (reception): 16 points or 15 points and 1 error input × 2 ports	16 outputs Output (transmission): 16 points	32 outputs Output (transmission): 16 points or 15 points and 1 error input × 2 ports	16 inputs and 16 outputs Input (transmission): 16 points or 15 points and 1 error input Output (reception): 16 points
Number of I/O Unit words allocated	1 input word	2 input words	1 output word	2 output words	1 input word and 1 output word (total: 2 words)
Communications method	Unidirectional, time-division multiplex				
I/O delay time	Normal speed (typical: 19.2 ms) or high speed (typical: 3 ms) (switchable)				
Transmission distance (see note 1)	Normal speed: 500 m max. High speed: 100 m max.				
Error processing	HOLD/LOAD OFF (switchable)	---			HOLD/LOAD OFF (input only) (switchable)
Internal current consumption	5 VDC, 100 mA max.				
External power supply (see note 2)	12 to 24 VDC ±10%, 0.11 A min.				

- Note:**
1. The maximum transmission distance varies depending on the wiring method.
 2. The value for the external power supply does not include the power required by the B7A Link Terminals.

Installation

■ Example of Connection to a B7A Link Terminal (CQM1-B7A21)

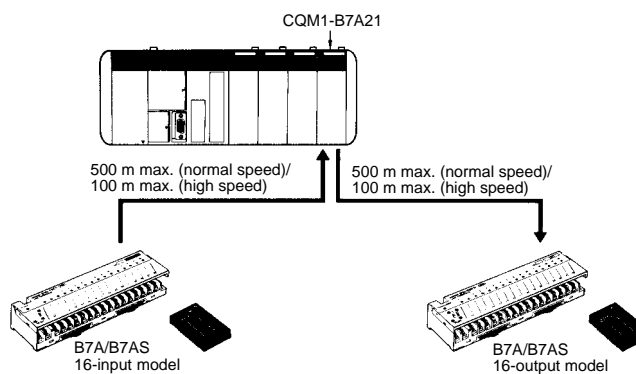

Ideal for reducing wiring between CS1-series and C200HS/HX/HG/HE PLCs and I/O devices installed up to 500 m away

- Mount like any other PLC Unit to reduce wiring and save space.
- Select from the following 6 types according to the number of I/O points required: models with 16 inputs, 16 outputs, 32 inputs, 32 outputs, 16 inputs and 16 outputs, or 32 inputs and 32 outputs.
- I/O data exchange with B7A Link Terminals enables connection to I/O devices such as switches and lamps in remote locations without special consideration of communications.
- Use like a basic I/O Unit or Group-2 Unit. Special I/O Unit mounting restrictions do not apply.
- Both normal I/O delay and short I/O delay available with each model (except 16-input and 16-output models).

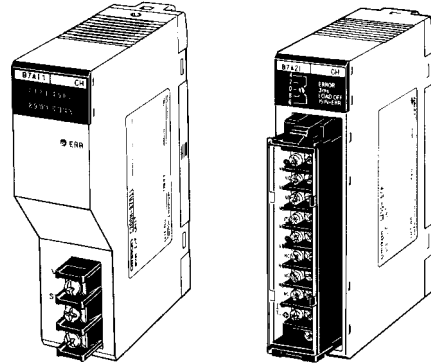

Ordering Information

■ Connectable B7A Link Terminals

Input Models

Type	Model	I/O delay time
Screw terminal models	B7A-T6□1	Normal speed: 19.2 ms
	B7AS-T6□1	
	B7A-T6□6	High speed: 3 ms
	B7AS-T6□6	
	B7AS-T3BS	Switchable
	B7AM-6BS	
Modular models	B7A-T6D2	Normal speed: 19.2 ms
	B7A-T6D7	High speed: 3 ms
Hybrid IC models	B7AH-T6D3	Normal speed: 19.2 ms
	B7AH-T6D8	High speed: 3 ms
PLC connector models	B7A-T6E3	Normal speed: 19.2 ms
	B7A-T6E8	High speed: 3 ms
	B7A-T3E3	Normal speed: 19.2 ms
	B7A-T3E8	High speed: 3 ms

Output Models

Type	Model	I/O delay time
Screw terminal models	B7A-R6□□1	Normal speed: 19.2 ms
	B7AS-R6□□1	
	B7A-R6□□6	High speed: 3 ms
	B7AS-R6□□6	
	B7AM-6BS	Switchable
	G70D-R6R□1-B7A	Normal speed: 19.2 ms
G70D-R6M□1-B7A		
Modular models	B7A-R6A52	Normal speed: 19.2 ms
	B7A-R6A57	High speed: 3 ms
Hybrid IC models	B7AH-R6D53	Normal speed: 19.2 ms
	B7AH-R6D58	High speed: 3 ms
PLC connector models	B7A-R6A□3	Normal speed: 19.2 ms
	B7A-R6A□8	High speed: 3 ms
	B7A-R3A□3	Normal speed: 19.2 ms
	B7A-R3A□8	High speed: 3 ms

Note: Use combinations of B7A Interface Units and B7A Link Terminals that have the same I/O delay time. Connection is not possible for 10-point B7A Link Terminals.

Specifications

■ Characteristics

General

Item	C200H-B7A12	C200H-B7A02	C200H-B7A21	C200H-B7A22	C200H-B7A11	C200H-B7A01
Number of I/O points	32 inputs Input (reception): 16 points or 15 points and 1 error input × 2 ports	32 outputs Output (transmission): 16 points × 2 ports	16 inputs and 16 outputs Input (reception): 16 points or 15 points and 1 error input Output (transmission): 16 points	32 inputs and 32 outputs Input (reception): 16 points or 15 points and 1 error input × 2 ports Output (transmission): 16 points × 2 ports	16 inputs Input (reception): 16 points or 15 points and 1 error input	16 outputs Output (transmission): 16 points
Number of I/O Unit words allocated	2 input words (Group-2)	2 output words (Group-2)	1 input word and 1 output word (total: 2 words; Group-2)	2 input words and 2 output words (total: 4 words; Group-2)	1 input word (basic I/O Unit)	1 output word (basic I/O Unit)
Communications method	Unidirectional, time-division multiplex					
I/O delay time	Normal speed (typical: 19.2 ms) or high speed (typical: 3 ms) (switchable)				Normal speed (typical: 19.2 ms)	
Transmission distance (see note 2)	Normal speed: 500 m max. High speed: 100 m max.				500 m max.	
Error processing	HOLD/LOAD OFF (switchable)	---	HOLD/LOAD OFF (input only) (switchable)		HOLD	---
Internal current consumption	5 VDC, 100 mA max.					
External power supply (see note 3)	12 to 24 VDC ±10%, 50 mA min.	12 to 24 VDC ±10%, 60 mA min.	12 to 24 VDC ±10%, 50 mA min.	12 to 24 VDC ±10%, 80 mA min.	12 to 24 VDC ±10%, 10 mA min.	12 to 24 VDC ±10%, 30 mA min.

- Note:**
1. When using the C200H-B7A01 with a C200HS/C200H PLC, use a Backplane with “-V□” at the end of the model number. Normal operation will not be possible if any other type of Backplane is used.
The C200H-B7A01/12/21/22 cannot be used with a C200H-CPU01/02/03.
 2. The maximum transmission distance varies depending on the wiring method.
 3. The value for the external power supply does not include the power required by the B7A Link Terminals.

Installation

■ Example of Connection to a B7A Link Terminal (C200H-B7A21)

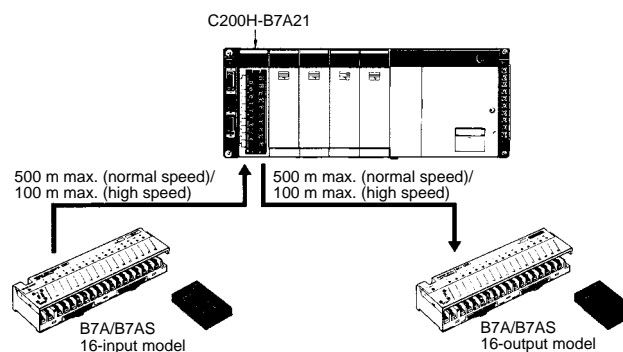

Operation

Note: The undermentioned is common for all B7A-series Link Terminals.

■ Connection of B7A and Programmable Controller

Each terminal of the B7A should be used for only single signal transmission without a transmission host. Therefore the B7A cannot be connected to OMRON's SYSMAC BUS Remote I/O System. To transmit signals from the B7A to a PLC, connect the B7A's terminals to an I/O Unit mounted on the PLC.

Refer to *B7A-series Models with PLC Connectors and Connecting PLCs* on page 39 for details.

Recommended Combinations of I/O Unit and B7A

Output

Model	Conditions of PLC	C500 I/O Unit			C200H I/O Unit				
		ID213	ID218	ID219	ID212	ID215	ID501	ID216	ID217
		12 to 24 VDC	12 to 24 VDC	24 VDC	24 VDC	24 VDC	5 VDC	24 VDC	24 VDC
		+ common	+/- common	+ common	+/- common	+/- common	+/- common	+/- common	+/- common
		16 points	32 points	64 points	16 points	32 points	32 points	32 points	64 points
B7A-R6B11 B7A-R6B31 B7A-R6B16 B7A-R6B36 B7A-R6A52 B7A-R6A57 B7AS-R6B11 B7AS-R6B31 B7AS-R6B16 B7AS-R6B36 B7AM-6BS B7AM-8B11 B7AM-8B31 B7AM-8B16 B7AM-8B36 B7A-R10SC01 B7A-R10MC	DC or AC/DC input and + common or +/- common (- common if the PLC with non-voltage input is used.)	Yes	Yes	Yes	Yes	Yes	Yes (see note 1)	Yes	Yes
B7A-R6F11 B7A-R6F31 B7A-R6F16 B7A-R6F36	DC or AC/DC input and - common or +/- common (+ common if the PLC with non-voltage input is used.)	No	Yes	No	Yes	Yes	No	Yes	Yes

Input

Model	Conditions of PLC	C500 I/O Unit			C200H I/O Unit				
		OC221	OD212	OD412	OC225	OD215	OD212	OD218	OD219
		Relay output	PNP output	NPN output	Relay	NPN output	NPN output	NPN output	NPN output
		24 VDC	12 to 24 VDC	12 to 48 VDC	24 VDC	5 to 24 VDC	24 VDC	5 to 24 VDC	24 VDC
		16 points	32 points	32 points	16 points	32 points	16 points	32 points	64 points
B7A-T6A1 B7A-T6A6 B7A-T6B1 B7A-T6B6 B7AS-T6B1 B7AS-T6B6 B7AM-6BS B7AM-8B11 B7AM-8B31 B7AM-8B16 B7AM-8B36 B7A-T10S1 B7A-T10S3	NPN transistor output (residual voltage must be 1.6 V max. if the B7A has 10 output points.) Relay output	Yes	No	Yes	Yes	Yes	Yes	Yes	Yes
B7A-T6C1 B7A-T6C6	PNP transistor output, relay output	Yes	Yes	No	Yes	No	No	No	No
B7A-T6D2 B7A-T6D7	TTL output (see note 1), PNP transistor output	See note 2	Yes	See note 2	See note 2	See note 2	See note 2	See note 2	See note 2
B7A-T10M2	TTL output (see note 1)	See note 2	See note 2	See note 2	See note 2	See note 2	See note 2	See note 2	See note 2

- Note:**
1. An independent power supply for the PLC is required due to the difference in operating voltage between the PLC and B7A.
 2. An external interface unit is required.

Examples of Connections with PLC I/O Units

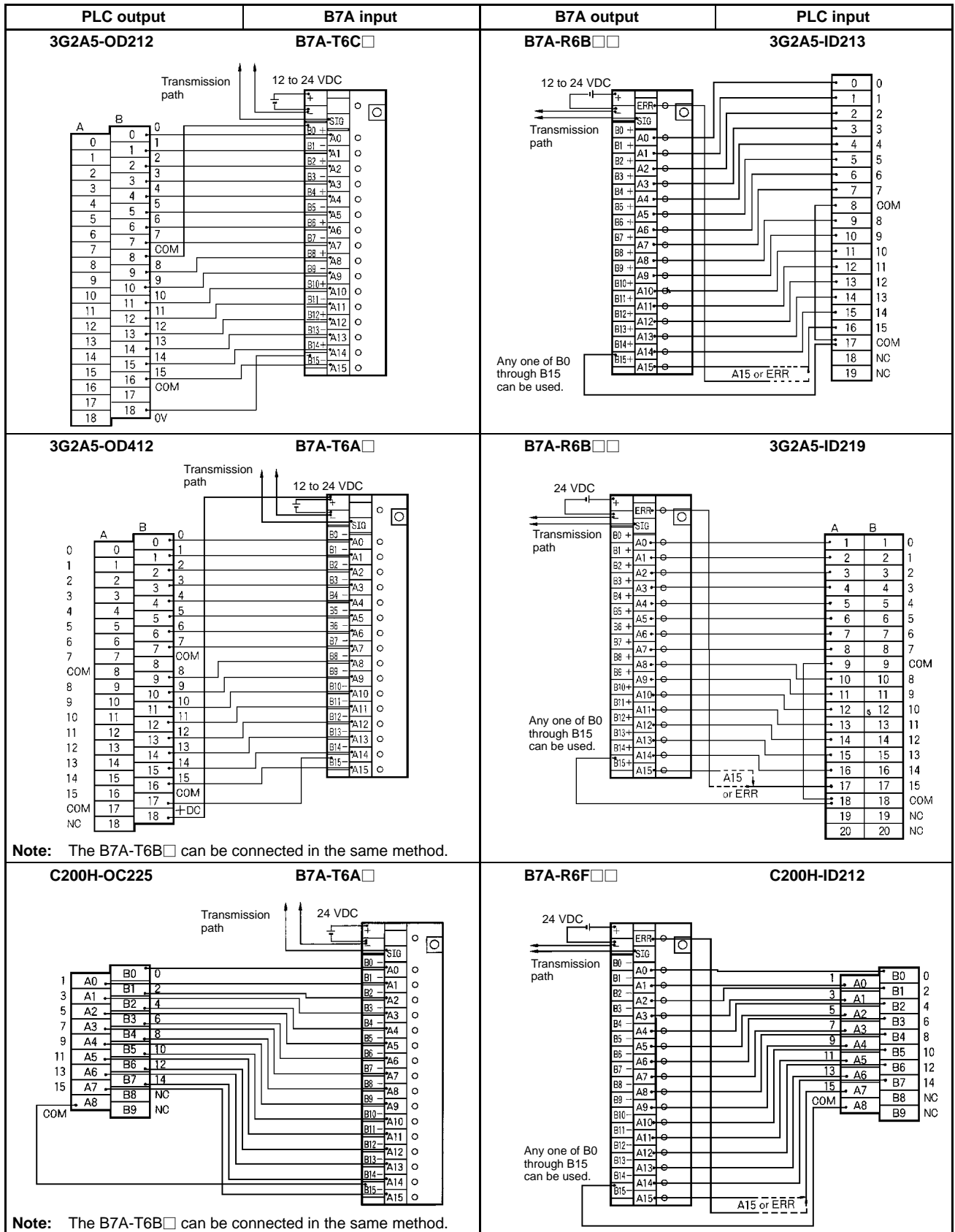

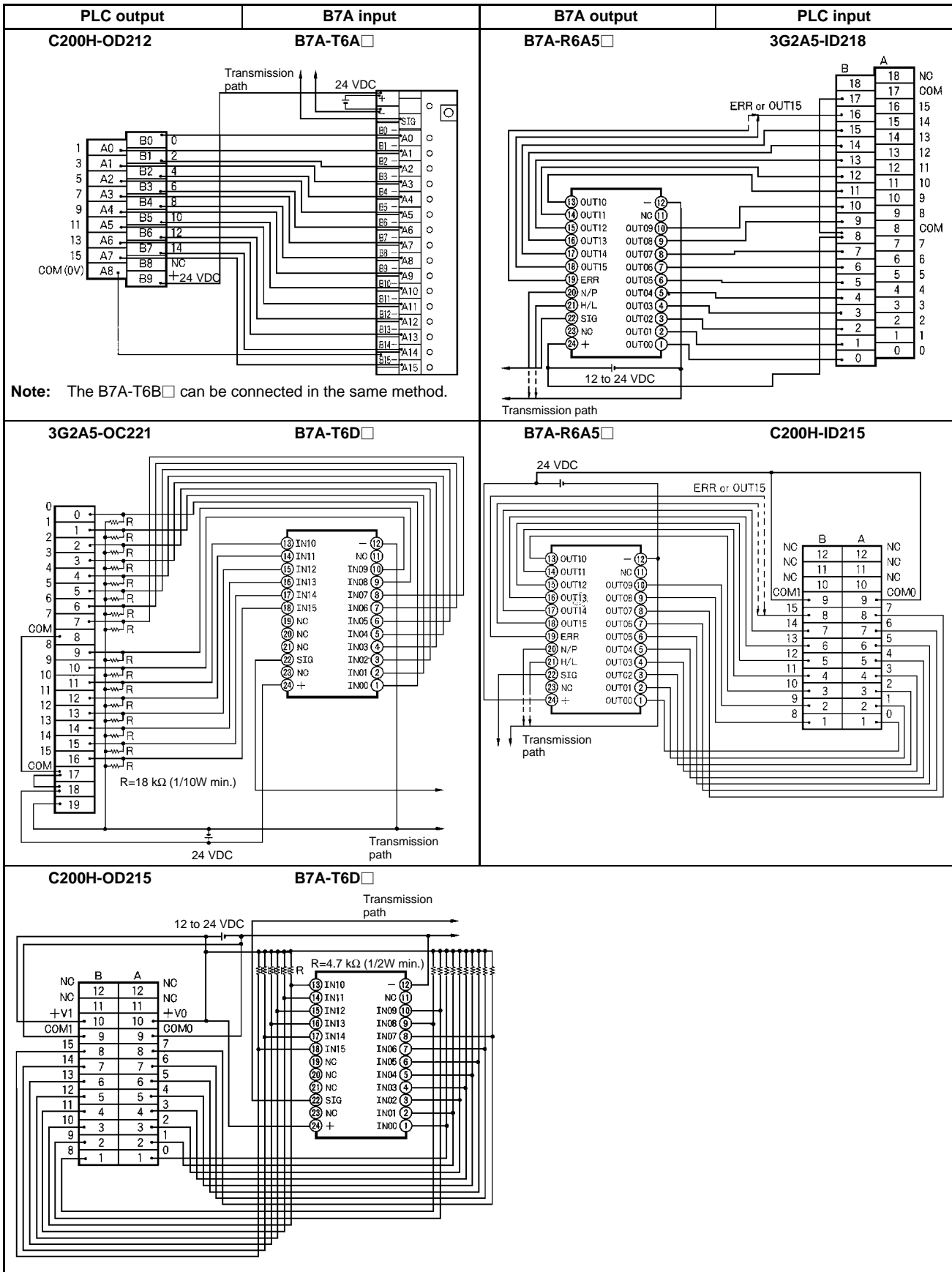

■ Peripheral Circuits of Modular Model

Input Interface Circuit

The modular model has a minimum ON discrimination voltage of 2.2 V and a maximum OFF discrimination voltage of 0.8 V, which are suitable for TTL circuits. If sensors are used for input, the following input circuits are required.

Two-wire DC Sensor Input

If a two-wire DC sensor is used for input, current limit resistor R_1 and leakage current diverter R_2 are required as shown in the diagram below. The following table lists R_1 and R_2 values for the E2E-XD-N Two-wire DC Proximity Sensor (with a current leakage of 0.8 mA maximum, a residual voltage of 3 V maximum, and a minimum control output current of 3 mA).

Input Interface (E2E-XD-N)

Supply voltage	12 V	24 V
R_1	1,800 Ω	5,600 Ω
R_2	820 Ω	820 Ω

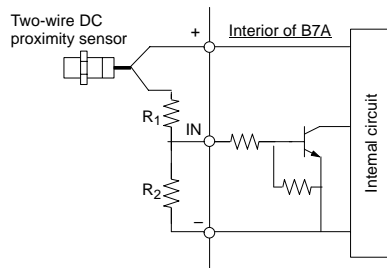

Input with B7A and Common Power Supply (12 to 24 VDC) (10-point Modular Model only)

The 10-point modular model has an input voltage range of 0 to 5 VDC. If a common power supply is connected, current limit resistor R_3 is required as shown in the diagram below. Use the following formula to calculate the value of R_3 .

$$R_3 = \frac{\text{Supply voltage } V_S \text{ (V)} - 1.4 \text{ (V)}}{\text{Input current } (2 \times 10^{-3} \text{ (A)})} - 2,200 \text{ } (\Omega)$$

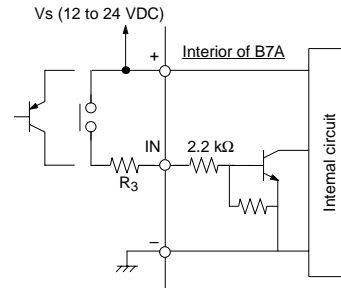

Note: The 16-point module's input voltage range is 0 V to the power supply voltage. Therefore no current limit resistor is required.

Noise Protection Circuits

If there is a possibility of noise interference from the power supply, input, and/or output lines, add the following noise protection circuits.

Power supply noise protection circuit	Input noise protection circuit	Output noise protection circuit
<p>12 to 24 VDC</p> <p>R: 10 to 20 Ω (1/8 W min.)</p> <p>C: 33 μF min. with a dielectric strength of 50 V min.</p>	<p>Input device</p> <p>V_{1N}</p> <p>C: 0.1 μF min.</p> <p>R: Photocoupler input current limit resistor</p>	<p>Photocoupler</p> <p>R: Photocoupler input current limit resistor</p> <p>ZD: $V_{ZD} = 36$ V (with a power consumption of 1 W min.)</p>
	<p>Input device</p> <p>ZD: $V_{ZD} = 36$ V (with a power consumption of 1 W min.)</p>	<p>ZD: $V_{ZD} = 36$ V (with a power consumption of 1 W min.)</p>

■ Transmission Errors and Output Signals

Transmission errors occur in the following cases:

- When the signal or 0-V wire is disconnected.
- When the signal is influenced by high-level external noise or the signal is excessively deformed because the length of the transmission path is more than the permissible distance.
- When the supply voltage to the Link Terminals are not within the operating voltage range (12 to 24 V \pm 10%).
- Immediately after the Link Terminals are turned on.
(An error is reset within 300 ms after the power is turned on.)

Output Signals

HOLD: When an error occurs, the output signals just before the occurrence of the error will be maintained.

LOAD OFF: When an error occurs, all output signals will be turned OFF.

Automatic Reset

When the error is corrected, the Link Terminals will automatically reset themselves.

■ I/O Status Signal Configuration

Input Models

Type	Applicable model	ON/OFF	Circuit	Suitable input example
Screw terminals	B7A-T6A1 B7A-T6A6 B7AM-6BS B7AM-8B11 B7AM-8B31 B7AM-8B16 B7AM-8B36 B7A-T10S1	For switches ON: Switch is closed. OFF: Switch is open.		A3G Pushbutton Switch (microload) WL01□ Limit Switch
	B7A-T10S3	For photoelectric sensors and proximity sensors (NPN) ON: Sensor signal is ON (residual voltage is 1.6 V max.). OFF: Sensor signal is OFF.		E2E-X□E Proximity Sensor E3S Photoelectric sensor
	B7A-T6B1 B7AS-T6B1 B7A-T6B6 B7AS-T6B6 B7AM-6BS B7AM-8B11 B7AM-8B31 B7AM-8B16 B7AM-8B36	For photoelectric sensors and proximity sensors (NPN) ON: Sensor signal is ON (residual voltage is 4 V max.). OFF: Sensor signal is OFF.		E2E-X□E Proximity Sensor E3S Photoelectric sensor
	B7A-T6A1 B7A-T6A6 B7A/S-T6B1 B7A/S-T6B6 B7AM-6BS B7AM-8B11 B7AM-8B31 B7AM-8B16 B7AM-8B36	For proximity sensors (two-wire sensor with DC output) ON: Sensor signal is ON (residual voltage is 4 V max.). OFF: Sensor signal is OFF (leakage current is 1.5 mA max.).		E2E-XD-N 2-wire DC Inductive Proximity Sensor
	B7A-T6C1 B7A-T6C6 B7AM-8F31	For switches ON: Switch is closed. OFF: Switch is open.		A3G Pushbutton Switch (microload) WL01□ Limit Switch
		For proximity sensors (two-wire sensor with DC output) ON: Sensor signal is ON (residual voltage is 4 V max.). OFF: Sensor signal is OFF (leakage current is 1.5 mA max.).		E2E-XD-N 2-wire DC Inductive Proximity Sensor
		For photoelectric sensors and proximity sensors (PNP) ON: Sensor signal is ON (residual voltage is 4 V max.). OFF: Sensor signal is OFF.		E2E-X□F Proximity Sensor E3S Photoelectric sensor (B-type)

Type	Applicable model	ON/OFF	Circuit	Suitable input example
Module (see note)	B7A-T6D2 B7A-T6D7 B7A-T10M2	For switches ON: Switch is closed. OFF: Switch is open.		A3G Pushbutton Switch (microload) WL01□ Limit Switch
		For NPN open-collector inputs ON: Transistor is OFF. OFF: Transistor is ON. (residual voltage is 0.8 V max.)		3G2A5-OD213 C200H-OD215 PLC Transistor Output Unit
		For PNP open-collector inputs ON: Transistor is ON. OFF: Transistor is OFF.		C200H-OD216 C200H-OD217 PLC PNP Output Unit
		For IC (TTL, CMOS) inputs ON: Output is 2.2 V min. OFF: Output is 0.8 V max.		3G2A5-OD501CN C200H-OD501 PLC TTL Output Unit
PLC connector	B7A-T6E3 B7A-T6E8 B7A-T3E3 B7A-T3E8	For PLC output unit, NPN open collector ON: Transistor ON OFF: Transistor OFF		---

Note: The positive input voltage range of the B7A-T6D□ modular model is 0 to 24 VDC and the positive input voltage of the B7A-T10M2 modular model is 5 VDC.

Output Models

Type	Output configuration	Applicable model	ON/OFF	Circuit
Screw terminals	NPN open collector	B7A/S-R6B11 B7A/S-R6B31 B7A/S-R6B16 B7A/S-R6B36 B7AM-6BS B7AM-8B11 B7AM-8B31 B7AM-8B16 B7AM-8B36 B7A-R10SC01	For PLC input ON: PLC is ON. OFF: PLC is OFF.	
			For relays and solenoids ON: Operates. OFF: Reset.	
	PNP open collector	B7A-R6F11 B7A-R6F31 B7A-R6F16 B7A-R6F36 B7AM-8F31	For PLC input ON: PLC is ON. OFF: PLC is OFF.	
			For relays and solenoids ON: Operates. OFF: Reset.	
Module	NPN open collector	B7A-R6A52 B7A-R6A57 B7A-R10MC	For PLC input ON: PLC is ON. OFF: PLC is OFF.	
			For relays and display terminal ON: Operates. OFF: Reset.	
			For IC (TTL, CMOS) ON: Input is Low. OFF: Input is High.	
PLC connector	NPN open collector	B7A-R6A13 B7A-R6A18 B7A-R6A33 B7A-R6A38 B7A-R3A13 B7A-R3A18 B7A-R3A33 B7A-R3A38	For PLC input unit + common photocoupler input ON: PLC is ON. OFF: PLC is OFF.	

I/O ON/OFF Conditions

Input		Output			
		Screw terminal	Module		PLC connector
			Active high (N/P open)	Active low (N/P 0 V)	
Screw terminal	ON	ON	OFF	ON	ON
	OFF	OFF	ON	OFF	OFF
Module	ON	ON	OFF	ON	ON
	OFF	OFF	ON	OFF	OFF
PLC connector	ON	ON	OFF	ON	ON
	OFF	OFF	ON	OFF	OFF

Precautions

Note: The undermentioned is common for all B7A-series Link Terminals.

General

Each terminal of the B7A-series should be used for only single signal transmission without a transmission host. The B7A-series cannot be connected to OMRON's SYSMAC BUS Remote I/O System.

Avoid places subject to corrosive gasses or continual shock and/or vibration.

If high-level electrostatic discharge is generated at the installation site (e.g., for transfer of a molding material, powder, or liquid through a pipe), separate the Link Terminals as far as possible from the source of the electrostatic discharge.

If the Input and Output Terminals are connected via a three-conductor cable to transmit signals with a single power supply (i.e., the power supply is connected directly to one of the Link Terminals and indirectly to the other), the transmission distance greatly varies with the diameter of the cable. This is due to the potential difference between the current on the 0-V transmission wire and on the 0-V I/O transmission line caused by the resistance of the cable. By increasing the diameter of the cable (decreasing its resistance), the transmission distance can be increased. By reducing the resistance of the transmission path to 2.5Ω or less for example (i.e., increasing the thickness of the wire to 1.25 mm^2 or more), a transmission distance of 160 m will be achieved.

It is recommended that a switch for minute loads be connected to the 16-point screw terminal model because there is a contact input current of only 3 to 6 mA to the model from the connected switch or relay.

The Output Terminal has an error of 300 ms maximum after the Output Terminal is turned on. The user should be well aware of this before using error outputs.

Note: The 10-point and 16-point models cannot be connected to each other because their transmission signal data formats are not compatible.

Screw Terminal Models

Apply a torque of 0.78 to 1.18 N · m to tighten wiring terminals.

Hold both edges of the terminal cover to open it.

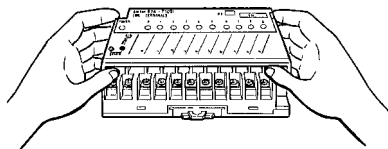

If the Input or Output Terminal is mounted to a panel with screws, apply a torque of 0.59 to 0.98 N · m to tighten the screws.

Modular Models

Soldering (with an soldering iron or in a soldering tab) must be completed within 5 s at a temperature of 260°C or less.

The supply voltage must be within the operating voltage range. Do not use a power supply which generates irregular voltages or large ripples.

Do not apply a strong acidic or alkaline solvent to the printed circuit board for removal of the flux. The module of the B7A 10-point model is not of closed-mold construction. The solvent must not remain on the bottom of the module after the module is cleaned. The module of the B7A 16-point model is of closed-mold construction.

The input and output circuits are not insulated. If Link Terminals are influenced by external noise, use photocouplers to insulate the I/O circuits.

Terminals with PLC Connector Models

Apply a torque of 0.78 to 1.18 N · m to tighten wiring terminals.

Be sure to disconnect the connector unit from the PLC's I/O connector unit when wiring the screw terminals in order not to impose excessive force on the PLC's I/O connector unit.

Use the B7A in combination with a PLC correctly, otherwise the B7A may be damaged. The following are correct combinations.

B7A Input Unit and PLC Output Unit
B7A Output Unit and PLC Input Unit

Wiring

Separate the transmission lines from high voltage or power lines as far away as possible and do not wire the transmission lines in parallel with high voltage or power lines. If Link Terminals are used near a device that generates noise, make sure that the Link Terminals do not malfunction due to the noise generated from the device.

Make sure to turn off the Link Terminals while wiring in order to avoid a short-circuiting accident that may damage the internal element(s) of the Link Terminals.

Link Terminals will malfunction if the SIG terminal is short-circuited with one of the power terminals or B□□ terminal. Before turning the power on, make sure that the SIG terminal is not short-circuited with these terminals.

Before checking the insulation resistance of the transmission path, disconnect the wires from the Link Terminals.

If the OUT terminal and positive power terminal of the Output Link Terminal is short-circuited during signal transmission, the Link Terminal will malfunction. Apply an appropriate load between these terminals.

When measuring the current, use a multimeter without disconnecting the load.

Recommended Cables

**For B7A with Normal I/O Delay
Cable Cable**

When a single power supply is connected to either the Input Terminal or Output Terminal:

- VCTF 0.75 x 4 C (B7AM)
- VCTF 0.75 x 3 C (B7A/S/C)

When independent power supplies are connected to both Link Terminals:

- VCTF 0.75 x 3 C (B7AM)
- VCTF 0.75 x 2 C (B7A/S)

The following cable can also be used.

Twisted Pair Wire

When a single power supply is connected to either the Input Terminal or Output Terminal, the thickness of the wire must be 0.75 mm² or greater.

Transmission distance: 100 m max.

**For B7A with Short I/O Delay
Shielded Wire**

Use a shielded wire with a thickness of 0.75 mm² min.

Color

Screw Terminal Models

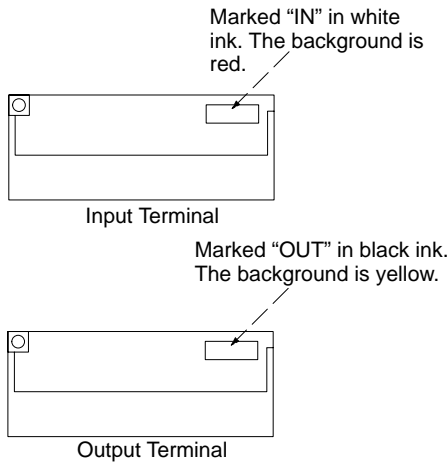

Insert a flat-blade screwdriver to part (C) to dismount the Input or Output Terminal from a DIN track.

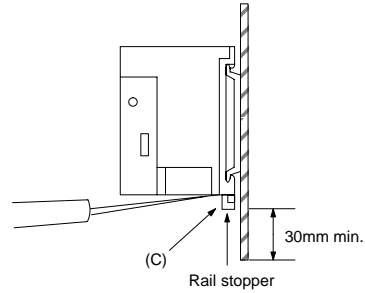

Mounting

To mount the Input or Output Terminal to a DIN track, hook the upper part (part (A) in the illustration) of the Input or Output Terminal on the DIN track first. Then press the Input or Output Terminal in the (B) direction.

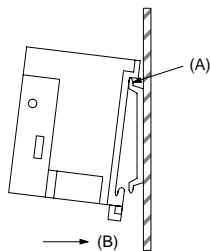

When mounting more than two Input or Output Terminals side by side, leave a space of 3 mm minimum between each Terminal.

It is recommended that PFP-S Spacers be used to secure a space of 3 mm between each Input or Output Terminal.

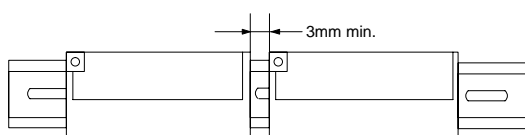



Allows Wireless Transmission of ON/OFF Signals from Input Devices and Power to Input Devices

- Makes use of electromagnetic coupling to transmit input signals to the B7A Output Unit and transmit power to the B7A Input Unit without wiring.
- Supplies power to the B7A Input Unit, which means it does not require an independent power supply, and receives input signals from rotating and moving devices.
- Wireless signal and power transmission through a nonmetal object (such as plastic or glass) is possible.

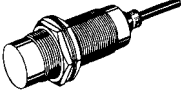
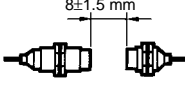

Ordering Information

Model	Classification	Appearance	Transmission distance (couplers)	I/O delay time
B7AP-S1 (see note)	Stationary Unit	M30 		Typical: 19.2 ms 31 ms max.
B7AP-M1	Moving Unit	M30 		

Note: The B7AP-S1 Power Coupler has a gauge that is used to adjust the transmission distance between the B7AP-S1 and B7AP-M1 Power Couplers.

■ B7A Models

Model	Applicable B7A Link Terminal	Max. I/O points (see note 1)	Applicable input device (see note 3)
B7AP-S1	B7A-R6B31	(See note 2)	---
	B7A-R6C31		
	B7A-R6F31		
	B7A-R6G31		
	B7A-R6A52		
	B7A-R6A33		
	B7A-R3A33		
	B7A-R3A33-M		
	B7AS-R6B31		
	B7AM-6BS		
	G70D-R6□□1-B7A		
	B7AH-R6D53		
B7AP-M1	B7A-T6□1	10 (16)	Two-wire sensor, contact
	B7A-T6D2	10 (16)	Contact
	B7A-T6E3	10 (16)	
	B7A-T3E3	10 (16)	
	B7A-T3E3-M	10 (16)	
	B7AS-T6B1	10 (16)	Two-wire sensor, contact
	B7AM-6BS	10 (16)	For CMOS input
	B7AH-T6D3	16	

- Note:**
1. The maximum I/O points refers the maximum I/O points handled simultaneously by the B7A Input and Output Units. Figures in parentheses indicate the maximum I/O points handled simultaneously by the B7A Input and Output Units each connected with an independent power supply. Refer to *Power Supplies* on page 110.
 2. The maximum I/O points are the same as the maximum input points of the B7A Input Unit connected to the B7AP-M1.
 3. PLCs and three-wire sensors can be connected only if the B7A Input and Output Units are each connected with an independent power supply. Refer to *Power Supplies* on page 110.

Specifications

■ Communications Specifications

Communications method	Unidirectional, time-division multiplex
Transmission distance (couplers)	8±1.5 mm
Transmission distance (B7A)	100 m max. (see note 1)
I/O delay time	Typical: 19.2 ms; 31 ms max.
Minimum coupler interfacing time	0.3 s (see note 2)
Minimum distance between Power Couplers mounted in parallel	60 mm

- Note:**
1. The value is for the case where a power supply is provided only for the B7AP-S1.
 2. Minimum coupler interfacing time is the minimum time required for signal and power transmission between the B7AP-S1 and B7AP-M1 Power Couplers.

■ Characteristics

Item	B7AP-S1	B7AP-M1
Power supply voltage	24 VDC ±10%	---
Current consumption	300 mA	---
Insulation resistance	100 MΩ min. (at 500 VDC) between each lead wire and external parts	
Dielectric strength	1,000 VAC, 50/60 Hz for 1 min between each lead wire and external parts	
Noise immunity	Noise level: 1.5 kV; pulse width: 100 ns to 1 μs (on transmission line due to coupling)	
Vibration resistance	10 to 55 Hz, 1.5-mm double amplitude	
Shock resistance	500 m/s ²	
Ambient temperature	Operating: -10 to 55°C (with no icing or condensation) Storage: -25 to 65°C (with no icing or condensation)	
Ambient humidity	Operating: 35% to 95% (with no condensation)	
Cable pulling strength	49 N	
Nut tightening strength	39 N • m	
Enclosure rating	IEC IP67	
Maximum cable length	2 m	
Weight	Approx. 300 g	Approx. 230 g
EMC	Radiated Emissions: EN55022 class A Radiated Immunity: prEN50082-2 Electrostatic Discharge: prEN50082-2 Burst Transients: prEN50082-2	
Approved standards	UL508 Conforms to EN50081-2, EN50082-2	

■ Moving Unit Specifications

Output voltage	12 VDC ±10%
Output current	38 mA

- Note:** Use the Moving Unit so that the total current consumption of all input devices is 38 mA max. if power is supplied to the input devices through the Moving Unit.

Engineering Data

Transmission Range (Reference)

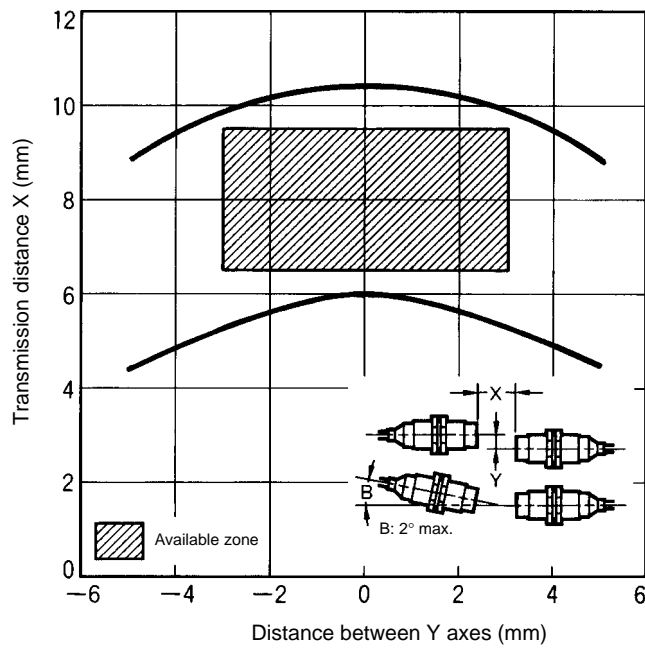

Operation

■ Power Supplies

Signal and Power Transmission (with Power Supplied to B7AP-S1)

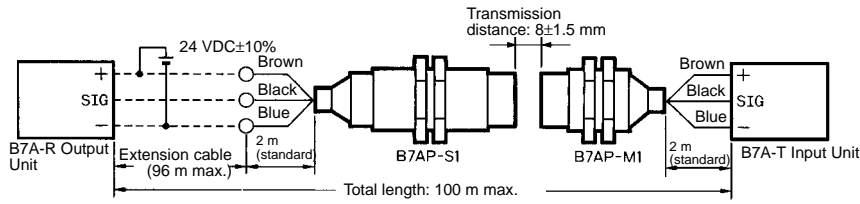

- Note:**
1. The thickness of the extension cable for the B7AP-S1 Power Coupler must be 0.75 mm² min.
 2. No extension cable can be connected to the B7AP-M1 Power Coupler. Use the original 2-m cable connected to the B7AP-M1 Power Coupler.
 3. Refer to *page 21, B7A Models* for the maximum input points of the B7A Input Unit.
 4. No PLC or three-wire sensor can be connected to the B7A Input Unit.

Signal Transmission Only (with Power Supplied to B7AP-S1 and B7AP-M1)

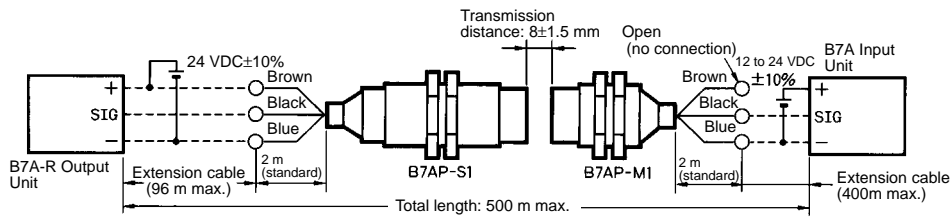

- Note:**
1. The thickness of the extension cable for the B7AP-S1 or B7AP-M1 Power Coupler must be 0.75 mm² min.
 2. For transmitting signals only, the brown lead wire of the B7AP-M1 Power Coupler must not be used. Insulate the brown lead wire with insulation tape so that the brown wire will not come in contact with any lead wire.
 3. The maximum input points of the B7A Input Unit are available.
 4. PLCs and three-wire sensors can be connected to the B7A Input Unit.

■ Indicators

Indicators		Function
Power indicator (B7AP-S1)	Lit	Lit when power is supplied to the Power Coupler.
	Not lit	Not lit when power is not supplied to the Power Coupler.
Operation indicator (B7AP-M1)	Lit	Lit when the B7AP-M1 and B7AP-S1 Power Couplers are properly set for wireless signal or power transmission at a transmission distance of 8 ± 1.5 mm.
	Not lit	Not lit when the B7AP-M1 and B7AP-S1 Power Couplers are not properly set for wireless signal or power transmission, or the B7AP-M1 Power Coupler has excessive loads.

B7AP-S1

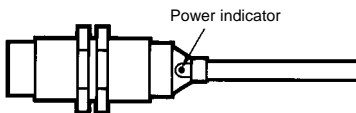

B7AP-M1

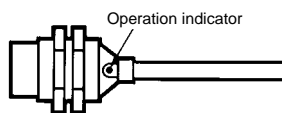

Dimensions

Note: All units are in millimeters unless otherwise indicated.

B7AP-S1

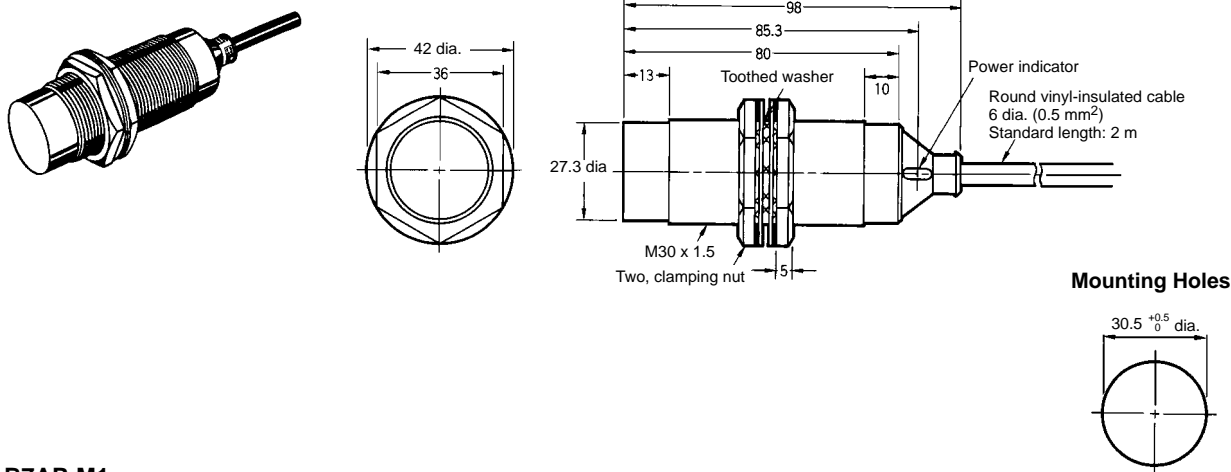

B7AP-M1

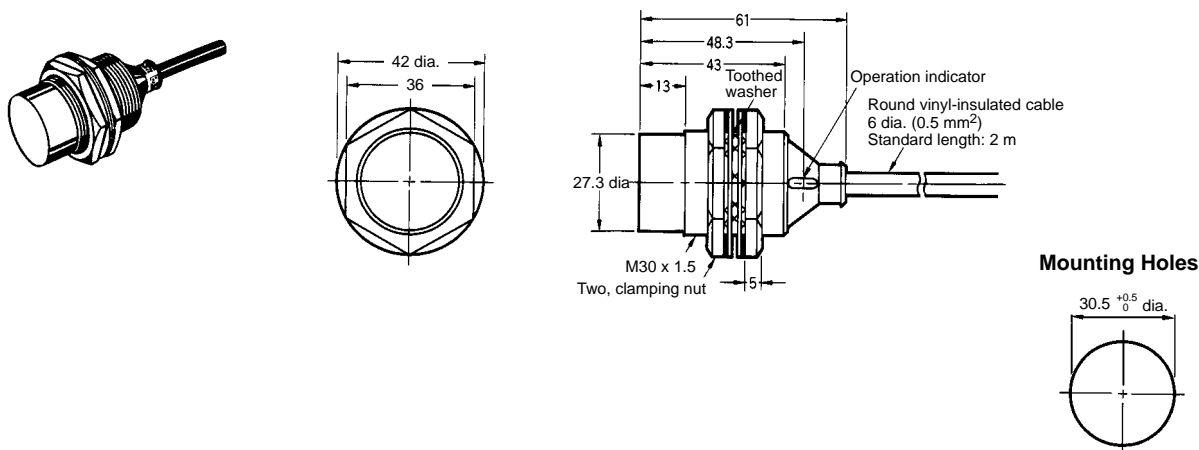

Installation

■ Connection

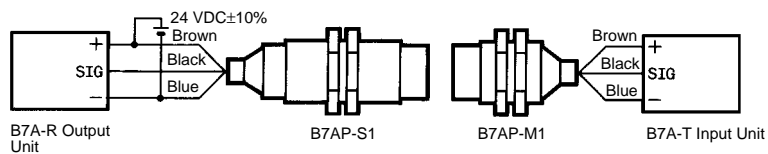

Precautions

General Precautions

Be careful when touching the B7AP-S1 Power Coupler during operation because the surface temperature of the B7AP-S1 Power Coupler will rise approximately 20°C after the B7AP-S1 Power Coupler starts power transmission. The surface temperature varies with the load of the sensing device connected to the B7AP-M1 Power Coupler and the transmission distance.

Correct Use

Handling

Use the B7AP-S1 and B7AP-M1 Power Couplers with the available B7A Link Terminals. Refer to *page 21, B7A Models*.

The M7E-12□□ Display Unit, M7E-20□□ Display Unit, and B7A Link Terminals with an I/O delay time of 3 ms cannot be used with the B7AP-S1 or B7AP-M1 Power Coupler.

Use the LOAD-OFF model for the B7A Output Unit to be connected to the B7AP-S1. When using a model that allows selection of error processing, set to the LOAD-OFF mode. This turns OFF signals right before an occurrence of a transmission error and prevents unexpected signal transmission when the transmission error is cleared.

Separate the Power Couplers 8±1.5 mm min. away from each other. The distance between the Power Couplers on standby must be 30 mm or more.

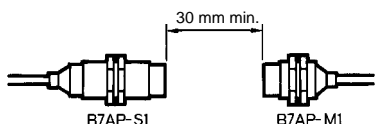

Do not supply power to the B7AP-S1 or B7AP-M1 Power Coupler while connecting the Power Couplers to the B7A Link Terminals. Connect the Power Couplers to the B7A Link Terminals correctly, otherwise the internal circuits of the Power Couplers may be damaged.

The SIG terminal must not contact with the power supply terminals, otherwise the internal elements may be damaged and normal transmission may not be possible.

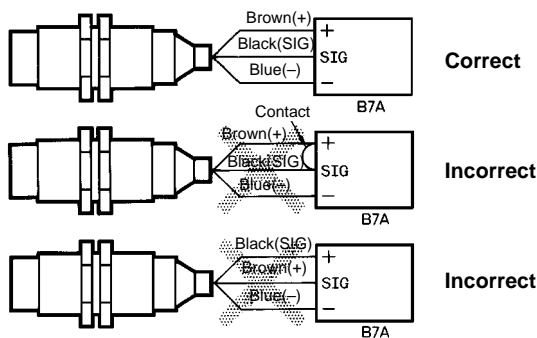

Wire the cables of the B7AP-S1 and B7AP-M1 Power Couplers through independent metal conduits to prevent the Power Couplers from being influenced by noise if there are power or high-tension lines nearby. Test the Power Couplers and make sure that the Power Couplers operate normally before they are put in actual operation.

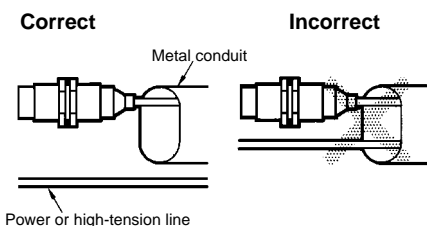

Do not subject the head of the B7AP-S1 or B7AP-M1 Power Coupler to excessive shock with hard objects.

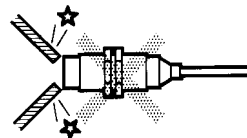

Do not use the B7AP-S1 or B7AP-M1 Power Coupler outdoors unless it is properly protected.

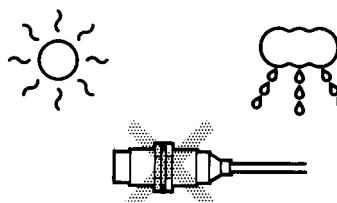

The B7AP-S1 and B7AP-M1 Power Couplers are products meeting the requirements of IP67. The B7AP-S1 or B7AP-M1 Power Coupler cannot be, however, used in water or oil.

Keep the heads of the B7AP-S1 and B7AP-M1 Power Couplers free from dust, otherwise improper signal or power transmission may result between the Power Couplers.

Mounting

Use nuts and serrated toothed washers and tighten the nuts to mount the B7AP-S1 and B7AP-M1 Power Couplers. The tightening torque applied to each of the nuts must be 39 N • m maximum. The mounting position will change and improper signal or power transmission may result between the Power Couplers if the nuts are not tightened properly.

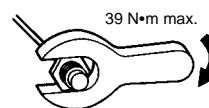

Transmission Distance for Stable Signal and Power Transmission

The B7AP-S1 Power Coupler has a gauge that is used to adjust the transmission distance between the B7AP-S1 and B7AP-M1 Power Couplers. Use the gauge to adjust the transmission distance to 8 mm, make sure that the green operation indicator of the B7AP-M1 Power Coupler is lit, and the B7A Output Unit has no error output before operating the Power Couplers.

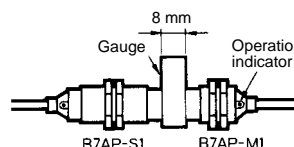

Monitoring Transmission Status

Judge from the power supply/error indicator and error output of the B7A Output Unit whether the B7AP-S1 and B7AP-M1 Power Couplers are facing each other properly.

The error output of the B7A Output Unit will be ON when the B7AP-S1 and B7AP-M1 Power Couplers are not facing each other properly.

Minimum Distance between Power Couplers Mounted in Parallel

When mounting the B7AP-S1 and B7AP-M1 Power Couplers in parallel, refer to the following table. Keep at least the specified minimum distance between adjacent Power Couplers for proper heat radiation by considering the temperature rise (approximately 20°C) of the B7AP-S1 Power Couplers in operation.

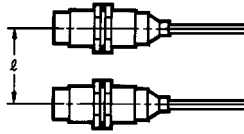

Item	B7AP-S1	B7AP-M1
ℓ	60 mm	60 mm

Effects of Surrounding Metal

The B7AP Power Coupler may malfunction when affected by surrounding metal. When mounting the B7AP within a metal panel, ensure that the clearances given in the following table are maintained. Be sure to check in advance that the B7AP operates properly.

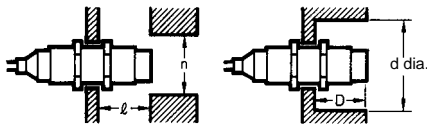

Item	B7AP-S1	B7AP-M1
ℓ	20 mm	20 mm
d	60 mm dia.	60 mm dia.
D	20 mm	20 mm
n	60 mm	60 mm

Maintenance

Regularly check the following for the stable operation of the B7AP-S1 and B7AP-M1 Power Couplers.

- The mounting positions and the tightening of the mounting nuts.
- The tightening, contacts, and breaking of the lead wires.
- Dust accumulation on the heads.
- The ambient operating temperature and other operating conditions.
- The transmission distance.

■ Product List

32-point Terminals

Screw Terminal Models

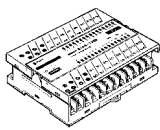
Appearance	Model	I/O classification	I/O configuration	I/O delay time (typical)	Internal I/O common	Error processing (see note 1)	Approved standards
	B7AS-T3BS	Input	NPN compatible	Normal speed 19.2 ms High speed 3 ms (switch selectable)	+/- common	---	U, CU, CE

16-point Terminals



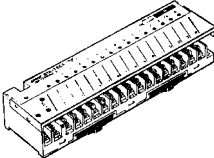
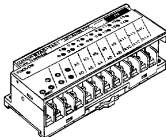

Screw Terminal Models

Appearance	Model	I/O classification	I/O configuration	I/O delay time (typical)	Internal I/O common	Error processing (see note 1)	Approved standards
	B7A-T6A1 (see note 2)	Input	NPN compatible	Normal speed 19.2 ms High speed 3 ms	- common	---	U, C, CE
	B7A-T6B1 (see note 2)				+/- common	---	
	B7A-T6C1		PNP compatible		+/- common	---	
	B7A-T6A6 (see note 2)		NPN compatible		- common	---	
	B7A-T6B6 (see note 2)				+/- common	---	
	B7A-T6C6		PNP compatible		+/- common	---	
	B7A-R6B11	Output	NPN open collector 100 mA/point	Normal speed 19.2 ms High speed 3 ms	+ common	HOLD	U, C, CE
	B7A-R6B31					LOAD OFF	
	B7A-R6C11		NPN open collector 500 mA/point (see note 3)		HOLD	CE	
	B7A-R6C31				LOAD OFF		
	B7A-R6F11		PNP open collector 100 mA/point		- common	HOLD	U, C, CE
	B7A-R6F31					LOAD OFF	
	B7A-R6G11		PNP open collector 500 mA/point (see note 4)		HOLD	CE	
	B7A-R6G31				LOAD OFF		
	B7A-R6B16		NPN open collector 100 mA/point		+ common	HOLD	U, C, CE
	B7A-R6B36					LOAD OFF	
	B7A-R6C16				NPN open collector 500 mA/point (see note 3)	HOLD	CE
	B7A-R6C36					LOAD OFF	
B7A-R6F16	PNP open collector 100 mA/point	- common		HOLD	U, C, CE		
B7A-R6F36				LOAD OFF			
B7A-R6G16	PNP open collector 500 mA/point (see note 4)	HOLD	CE				
B7A-R6G36		LOAD OFF					
	B7AS-T6B1	Input	NPN compatible	Normal speed 19.2 ms	+/- common	---	U, CU, CE
	B7AS-T6B6			High speed 3 ms		---	
	B7AS-R6B11	Output	NPN open collector 100 mA/point	Normal speed 19.2 ms High speed 3 ms		HOLD	U, CU, CE
	B7AS-R6B31					LOAD OFF	
	B7AS-R6B16					HOLD	
	B7AS-R6B36					LOAD OFF	

Note: 1. HOLD: The previous output condition will be on hold when an error results.
LOAD OFF: All outputs will be OFF when an error results.

2. The 16-point B7A-T6A□ and 16-point B7A-T6B□ are different from each other in terminal configuration. Refer to page 25 for details.
3. N-channel MOS-FET open drain output
4. P-channel MOS-FET open drain output

Modular Models

Appearance	Model	I/O classification	I/O configuration	I/O delay time (typical)	Error processing (see note)	Approved standards
	B7A-T6D2	Input	TTL input	Normal speed 19.2 ms	---	---
	B7A-T6D7			High speed 3 ms	---	
	B7A-R6A52	Output	NPN open collector 50 mA/point	Normal speed 19.2 ms	HOLD/LOAD OFF selected by wiring	
	B7A-R6A57			High speed 3 ms		
	B7A-T6D7-D	Input	NPN input	High speed 3 ms	---	---
	B7AH-T6D3	Input	CMOS input	Normal speed 19.2 ms	---	---
	B7AH-T6D8	Input		High speed 3 ms	---	
	B7A-R6A57-D	Output	NPN open collector 50 mA/point	High speed 3 ms	HOLD/LOAD OFF selected by wiring	---
	B7AH-R6D53	Output	CMOS output 2 mA/point	Normal speed 19.2 ms	HOLD/LOAD OFF selected by wiring	---
	B7AH-R6D58	Output		High speed 3 ms		

Note: HOLD: The previous output condition will be on hold when an error results.
LOAD OFF: All outputs will be OFF when an error results.

Terminals with PLC Connector

16-point Terminal Models

Appearance	Model	I/O classification	I/O configuration	I/O delay time (typical)	Error processing	Approved standards
	B7A-T6E3	Input	NPN compatible	Normal speed 19.2 ms	---	U, C, CE
	B7A-T6E8			High speed 3 ms		
	B7A-R6A13	Output	NPN open collector 50 mA/point	Normal speed 19.2 ms	HOLD	
	B7A-R6A33			LOAD OFF		
	B7A-R6A18			High speed 3 ms	HOLD	
	B7A-R6A38			LOAD OFF		

32-point Terminal Models

Appearance	Model	I/O classification	I/O configuration	I/O delay time (typical)	Error processing	Approved standards
	B7A-T3E3	Input	NPN compatible	Normal speed 19.2 ms	---	U, C, CE
	B7A-T3E8			High speed 3 ms		
	B7A-R3A13	Output	NPN open collector 50 mA/point	Normal speed 19.2 ms	HOLD	
	B7A-R3A33			LOAD OFF		
	B7A-R3A18			High speed 3 ms	HOLD	
	B7A-R3A38			LOAD OFF		

Terminals with 16 Relay Outputs

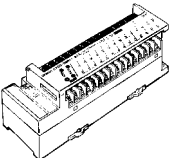
Appearance	Model	I/O classification	Relay configuration	I/O delay time (typical)	Error processing (see note)	Approved standards
	G70D-R6R11-B7A	Output	Relay output	Normal speed 19.2 ms	HOLD	---
	G70D-R6R31-B7A				LOAD OFF	
	G70D-R6M11-B7A	Power MOS FET relay output	HOLD			
	G70D-R6M31-B7A		LOAD OFF			

I/O Combination Models

Screw Terminal Model (with 16 Input and 16 Output Points)

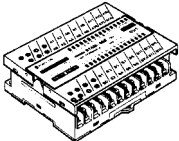
Appearance	Model	I/O configuration	I/O delay time (typical)	Error processing	Approved standards
	B7AM-6BS	NPN compatible/ NPN open collector 100 mA/point	Normal speed 19.2 ms High speed 3 ms (switch selectable)	HOLD/ LOAD OFF (switch setting)	---

Screw Terminal Models (with 8 Input and 8 Output Points)

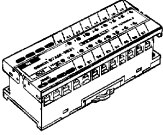
Appearance	Model	I/O configuration	I/O delay time (typical)	Error processing	Approved standards
	B7AM-8B11	NPN compatible/ NPN open collector 100 mA/point	Normal speed 19.2 ms	HOLD	---
	B7AM-8B31			LOAD OFF	
	B7AM-8B16	PNP compatible/ PNP open collector 100 mA/point	High speed 3 ms	HOLD	
	B7AM-8B36			LOAD OFF	
	B7AM-8F31	Normal speed 19.2 ms	LOAD OFF		

Terminals with FA Connector (M12)

10-point Terminal Models

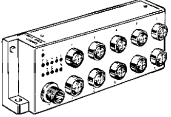
Appearance	Model	I/O configuration	I/O delay time (typical)	Contact arrangement	Approved standards
	B7AC-T10A1	NPN compatible	19.2 ms	Type A	U, CU, CE
	B7AC-T10A1-A		19.2 ms/3 ms (switchable)		---
	B7AC-T10A1-B	PNP compatible	19.2 ms/3 ms (switchable)		

10-point Terminals

Screw Terminal Models

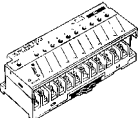
Appearance	Model	I/O classification	I/O configuration	Internal I/O common	Error processing (see note 1)	Approved standards
	B7A-T10S1 (see note 2)	Input	NPN compatible (No two-wire sensor can be connected.)	- common	---	U, C, CE
	B7A-T10S3 (see note 2)			+/- common	---	
	B7A-R10SC01	Output	NPN open collector 100 mA/point	+ common	HOLD	

Note: 1. HOLD: The previous output condition will be on hold when an error results.



2. The 10-point B7A-T10S1 and 10-point B7A-T10S3 are different from each other in terminal configuration. Refer to page 91 for details.

Modular Models

Appearance	Model	I/O classification	I/O configuration	Error processing (see note 1)	Approved standards
	B7A-T10M2	Input	TTL input	---	---
	B7A-R10MC	Output	NPN open collector 50 mA/point	HOLD	

Note: HOLD: The previous output condition will be on hold when an error results.

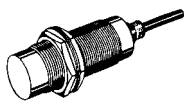
Power Couplers

Appearance	Model	Classification	I/O delay time (typical)	Communications method	Transmission distance	Approved standards
	B71AP-S1 (see note)	Stationary Unit	Normal speed 19.2 ms	Unidirectional, time-division multiplex	8±1.5 mm (couplers)	U, CU
	B7AP-M1	Moving Unit				

Note: The B7AP-S1 Power Coupler has a gauge that is used to adjust the transmission distance between the B7AP-S1 and B7AP-M1 Power Couplers.

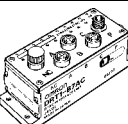

DeviceNet B7AC Interface Terminal (10 Input Points × 3)

Appearance	Model	I/O connection configuration	I/O delay time (typical)	Number of ports	Number of I/O points	Approved standards
	DRT1-B7AC	FA connector	Normal speed 19.2 ms High speed 3 ms	3	30 points (10 points × 3 ports)	U, CU, CE

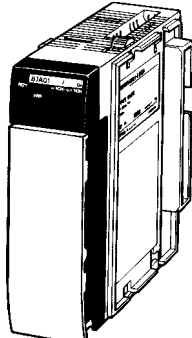
B7A Interface Units for CQM1/CQM1H PLCs

Appearance	Model	I/O classification	Number of I/O points	I/O delay time (typical)	Error processing	Number of I/O Unit words allocated	Approved standards
	CQM1-B7A21	Input and output	Input: 16 points Output: 16 points	Normal speed 19.2 ms High speed 3 ms (See note 1.)	HOLD/LOAD OFF (input only) (See note 2.)	Input: 1 word Output: 1 word (total: 2 words)	---
	CQM1-B7A13	Input	32 points (16 points × 2 ports)				
	CQM1-B7A12		16 points		---	Input: 1 word	U, C
	CQM1-B7A03	Output	32 points (16 points × 2 ports)				
	CQM1-B7A02		16 points		Output: 1 word		

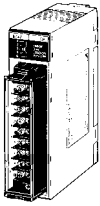
B7A Interface Units for CS1□/C200HS/HX/HG/HE PLCs

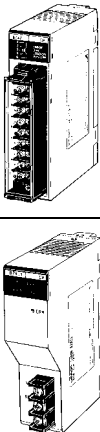
Appearance	Model	I/O classification	Number of I/O points	I/O delay time (typical)	Error processing	Number of I/O Unit words allocated	Approved standards
	C200H-B7A22	Input and output	Input: 32 points (16 points × 2 ports) Output: 32 points (16 points × 2 ports)	Normal speed 19.2 ms High speed 3 ms (See note 1.)	HOLD/LOAD OFF (input only) (See note 2.)	Input: 2 words Output: 2 words (total: 4 words) (Group-2)	U, C
	C200H-B7A21		Input: 16 points Output: 16 points			Input: 1 word Output: 1 word (total: 2 words) (Group-2)	
	C200H-B7A12	Input	32 points (16 points × 2 ports)		HOLD/LOAD OFF (See note 2.)	Input: 2 words (Group-2)	
	C200H-B7A11	Input	16 points	Normal speed 19.2 ms	HOLD	Input: 1 word (basic I/O Unit)	U, C, CE
	C200H-B7A02	Output	32 points (16 points × 2 ports)	Normal speed 19.2 ms High speed 3 ms (See note 1.)	---	Output: 2 words (Group-2)	U, C
	C200H-B7A01		16 points				

- Note:**
1. The I/O delay time can be switched between normal speed and high speed.
 2. The error processing method can be switched between HOLD and LOAD OFF.
 3. C200H-CPU01/02/03/11 cannot be used.

Approved Standards

The "approved standards" column in the above table indicates approval for (UL, CSA, cULus, cUL, NK, or Lloyds) or compliance with (EC Directives) the relevant standard or directive as of the end of April, 2001. Enquire separately for details on the conditions required to meet these standards and directives.

EMC Directive

OMRON devices that comply with EC Directives also conform to the related EMC standards so that they can be more easily built into other devices or the overall machine. The actual products have been checked for conformity to EMC standards (see the following note). Whether the products conform to the standards in the system used by the customer, however, must be confirmed by the customer.

EMC-related performance of the OMRON devices that comply with EC Directives will vary depending on the configuration wiring, and other conditions of the equipment or control panel on which the OMRON devices are installed. The customer must, therefore, per-

form the final check to confirm that devices and the overall machine conform to EMC standards.

Applicable EMC Standards

EMS (Electromagnetic Susceptibility):
EN61131-2

EMI (Electromagnetic Interference):
EN50081-2

(Radiated emission: 10-m regulations)

Low Voltage Directive

OMRON Power Supply Units and I/O Units have been determined safe when operating at voltages of 50 to 1,000 VAC and 75 to 1,500 VDC according to the safety standards in EN61131-2.