



# BAT54TB-AU~BAT54STB-AU

## SCHOTTKY BARRIER RECTIFIER

<b>Voltage</b>	<b>30 V</b>	<b>Current</b>	<b>0.2 A</b>
----------------	-------------	----------------	--------------

### Features

- Low forward voltage drop
- Deal for automated placement
- Low power loss, high efficiency
- High surge current capability
- Lead free in compliance with EU RoHS 2.0
- Green molding compound as per IEC 61249 standard
- AEC-Q101 qualified

### Mechanical Data

- Case: SOT-523 Package
- Terminals: Solderable per MIL-STD-750, Method 2026
- Approx. Weight: 0.00007 ounces, 0.002 grams

### SOT-523

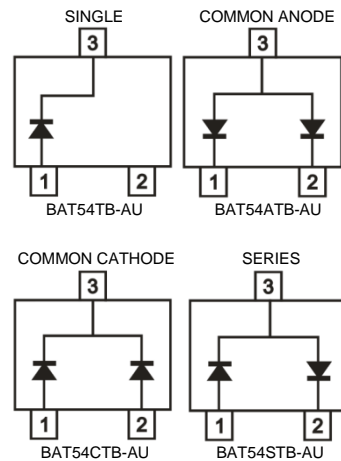
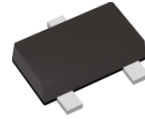

## Maximum Ratings and Thermal Characteristics ( $T_A = 25^\circ\text{C}$ unless otherwise noted)

PARAMETER	SYMBOL	LIMIT	UNITS
Maximum Repetitive Peak Reverse Voltage	$V_{RRM}$	30	V
Maximum Rms Voltage	$V_{RMS}$	21	V
Maximum Dc Blocking Voltage	$V_{DC}$	30	V
Maximum Average Forward Current	$I_{F(AV)}$	0.2	A
Peak Forward Surge Current: 1 s Single Half Sine-Wave Superimposed On Rated Load	$I_{FSM}$	0.6	A
Typical Junction Capacitance Measured at 1 MHz And Applied $V_R = 4\text{ V}$	$C_J$	4	pF
Typical Thermal Resistance	$R_{\theta JA}^{(1)}$	630	$^\circ\text{C/W}$
Operating Junction Temperature Range	$T_J$	-55~125	$^\circ\text{C}$
Storage Temperature Range	$T_{STG}$	-55~125	$^\circ\text{C}$



## BAT54TB-AU~BAT54STB-AU

### Electrical Characteristics ( $T_A = 25^\circ\text{C}$ unless otherwise noted)

PARAMETER	SYMBOL	TEST CONDITION	MIN.	TYP.	MAX.	UNITS
Forward Voltage	$V_F$	$I_F = 1\text{ mA}, T_J = 25^\circ\text{C}$	-	-	0.32	V
		$I_F = 100\text{ mA}, T_J = 25^\circ\text{C}$	-	-	0.6	
		$I_F = 1\text{ mA}, T_J = 100^\circ\text{C}$	-	0.17	-	
		$I_F = 100\text{ mA}, T_J = 100^\circ\text{C}$	-	0.48	-	
Reverse Current	$I_R^{(2)}$	$V_R = 24\text{ V}, T_J = 25^\circ\text{C}$	-	0.1	-	uA
		$V_R = 30\text{ V}, T_J = 25^\circ\text{C}$	-	-	2	
		$V_R = 30\text{ V}, T_J = 100^\circ\text{C}$	-	27	-	

**NOTES:**

1. Mounted on a FR4 PCB, single-sided copper, mini pad.
2. Short duration pulse test used to minimize self-heating effect.



# BAT54TB-AU~BAT54STB-AU

## TYPICAL CHARACTERISTIC CURVES

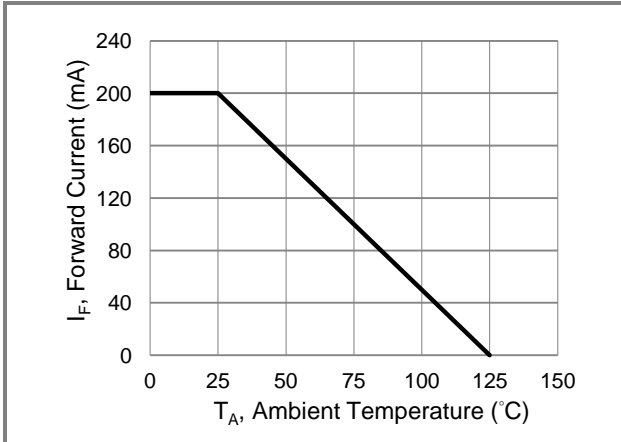

Fig.1 Forward Current Derating Curve

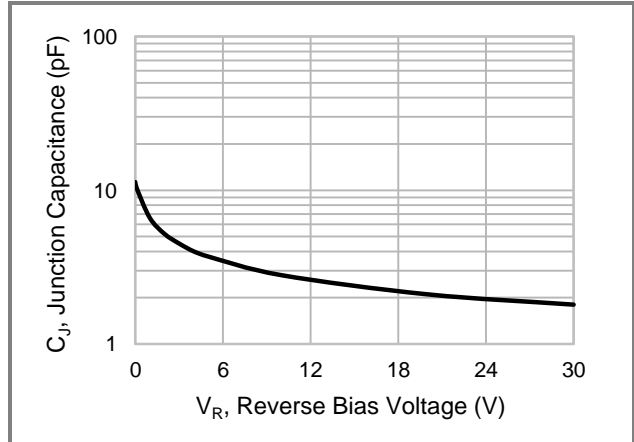

Fig.2 Typical Junction Capacitance

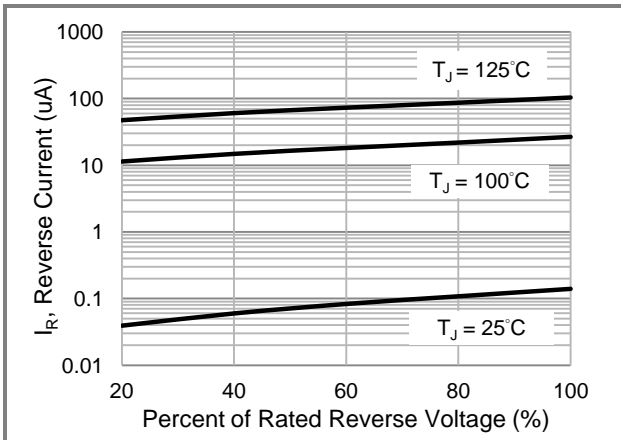

Fig.3 Typical Reverse Characteristics

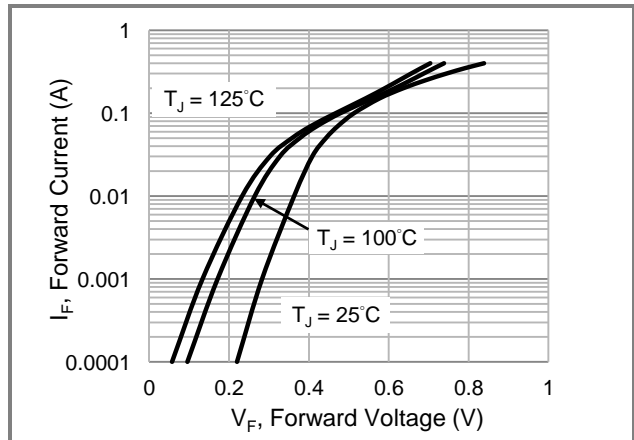

Fig.4 Typical Forward Characteristics

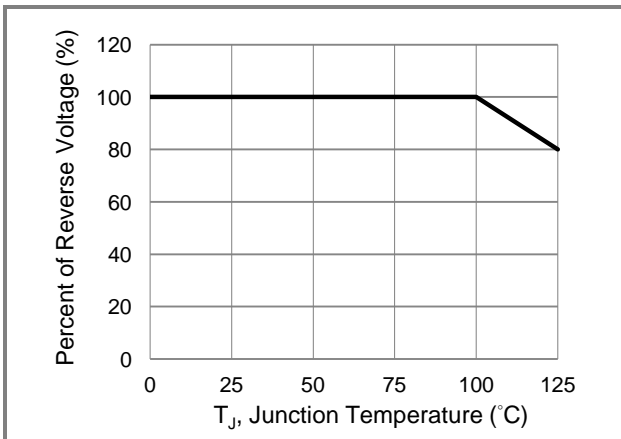

Fig.5 Operating Temperature Derating Curve



# BAT54TB-AU~BAT54STB-AU

## Part No Packing Code Version

Part No Packing Code	Package Type	Packing Type	Marking	Version
BAT54TB-AU_R1_000A1	SOT-523	4K / 7" Reel	LV	Halogen free
BAT54ATB-AU_R1_000A1	SOT-523	4K / 7" Reel	LW	Halogen free
BAT54CTB-AU_R1_000A1	SOT-523	4K / 7" Reel	LX	Halogen free
BAT54STB-AU_R1_000A1	SOT-523	4K / 7" Reel	LY	Halogen free

## Packaging Information & Mounting Pad Layout

