

# UM11817

## Introduction to 18-cell slider battery pack emulator

Rev. 1 — 17 February 2023

User manual

### Document information

Information	Content
Keywords	MC33774, battery cell controller, battery emulator, battery management systems
Abstract	This user manual provides the user with an overview of the BATT-18EMULATOR battery pack emulator.



Revision history

Rev	Date	Description
1	20230217	initial version

## 1 Introduction

The BATT-18EMULATOR board can emulate a multi-cell battery pack that can be easily hooked-up to the evaluation boards for MC33774 18-cell battery cell controllers (BCCs):

- RD33774ADSTEVB - distributed board with single MC33774
- RD33774CNT3EVB - centralized board with three MC33774

The user can connect the BATT-18EMULATOR board for a quick evaluation of NXP BCC ICs, or to help the users in their software development. These boards basically provide a very intuitive way:

- To change the voltage across any of the 18 cells of an emulated battery pack
- To change the voltage across some analog inputs of the BCC IC that are typically used as temperature sensors

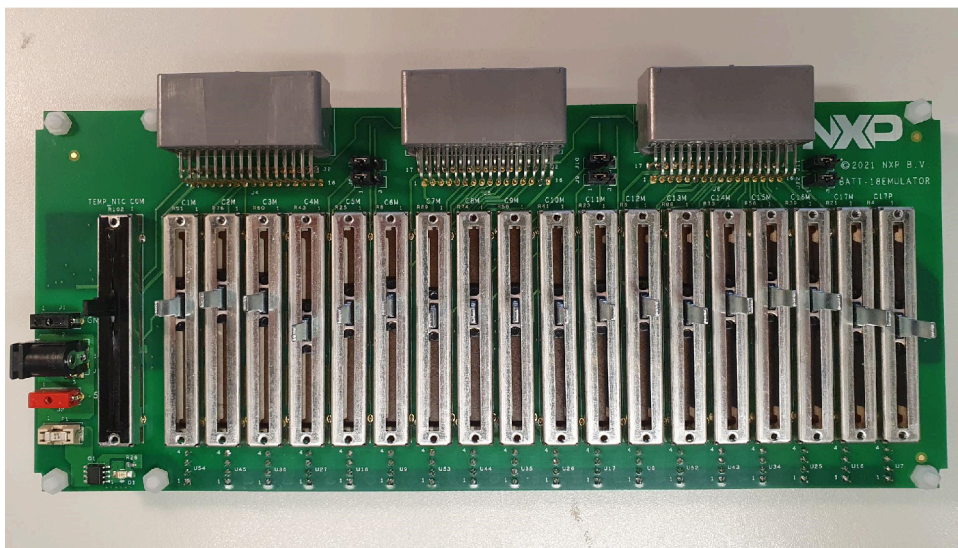

aaa-048977

Figure 1. BATT-18EMULATOR

## 2 Getting started

### 2.1 Kit contents/packing list

The kit contents include:

- BATT-18EMULATOR, 18-cell slider battery pack emulator
- 25 W AC-DC adapter with +5 VDC/5 A single output - DC plug type P1J (2.1 × 5.5 × 11 mm), tuning fork type, center positive
- Adapter cable DC plug 2.1 × 5.5 × 11 mm to 2.5 × 5.5 × 9.5 mm

### 3 Getting to know the hardware

#### 3.1 Board features

- 18 slider potentiometers to adjust the cells voltage between 1.2 V and 3.3 V. The maximum total voltage has been limited to 60 V.
- Three cells voltage can be inverted to apply voltages from -1.2 V to -3.3 V
- Maximum current capability per channel: 200 mA
- Three connectors for MC33774 evaluation boards connections
- Temperature sensor output voltage can vary from 0 V to +4.95 V to simulate negative temperature coefficient (NTC) sensor

#### 3.2 Board functions

The board has been designed and optimized for the operating conditions described in [Table 1](#) and [Table 2](#). Usage of the board beyond these conditions can lead to malfunction and damage.

**Table 1. Limiting values**

*In accordance with the Absolute Maximum Rating System (IEC 60134).*

Symbol	Parameter	Conditions	Min	Max	Unit
V <sub>DDI(p)</sub>	power input supply voltage		4.5	5.5	V
I <sub>DDI(p)</sub>	power input supply current		[1] 0.5	4	A
I <sub>O(cell)</sub>	cell output current		-	200	mA
T <sub>amb</sub>	ambient temperature		-10	+40	°C

[1] The maximum input supply current depends on the setup: number of boards connected, cells voltage, activated cell balancing channels; see [Section 3.3.3](#).

**Table 2. Electrical characteristics**

Symbol	Parameter	Conditions	Min	Typ	Max	Unit
V <sub>O(cell)(min)</sub>	minimum cell output voltage	slider down	-	1.2	-	V
V <sub>O(cell)(max)</sub>	maximum cell output voltage	slider up	[1] -	3.3	-	V
V <sub>O(sen)t(min)</sub>	minimum temperature sensor output voltage	slider down	-	0	-	V
V <sub>O(sen)t(max)</sub>	maximum temperature sensor output voltage	slider up	-	4.95	-	V
V <sub>isol</sub>	isolation voltage	between input power supply and battery emulator outputs	-	1.5	-	kV

[1] With jumpers setting, it is possible to get negative voltages from -3.3 V to -1.2 V for cells 13, 8 and 4; see [Section 3.3.4](#).

### 3.3 Board functional description

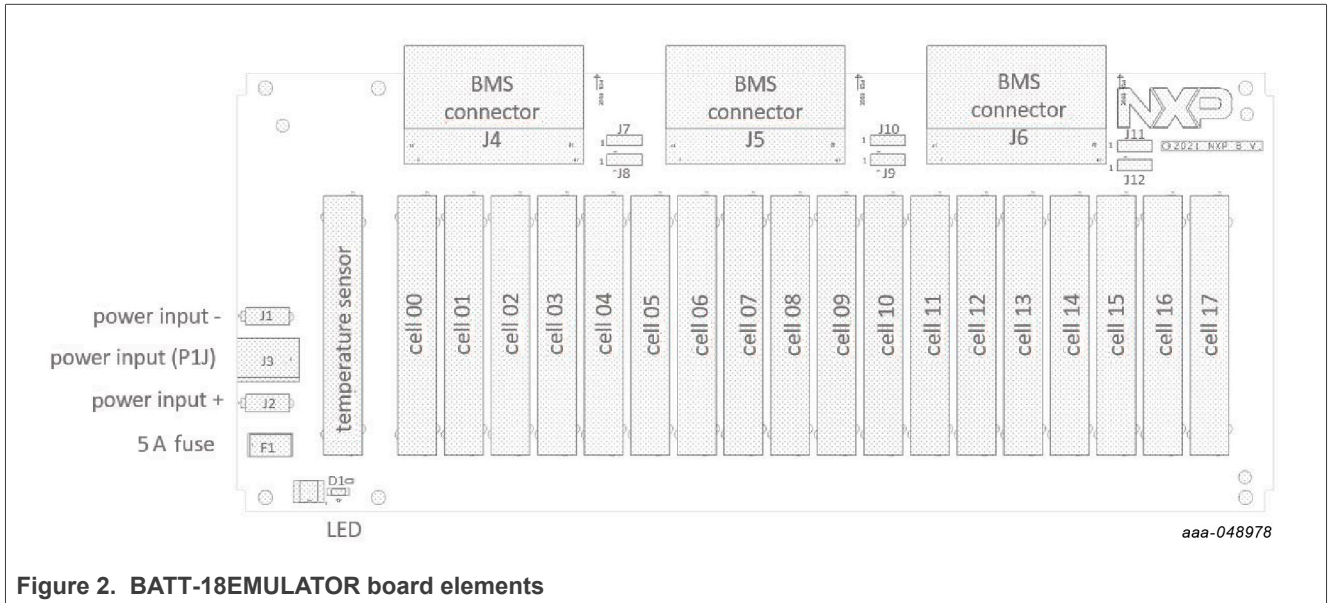

Figure 2. BATT-18EMULATOR board elements

#### 3.3.1 Description

Each cell emulation is made of a 5 V to 5 V unregulated isolated DC-DC converter and an adjustable regulator. The regulator output voltage is set thanks to a voltage slider. Minimum voltage is 1.2 V and maximum is set to 3.3 V.

#### 3.3.2 Connection and configuration

The emulator board requires a 5 V DC power supply with 5 A current capability. The power supply is connected to the board via J3 a Ø2.5 mm jack connector or using the 2 mm bananas J2(+) and J1(-). The center pin is connected to the positive voltage and the ring terminal to the ground. The input of the board is 5 A fuse protected. An LED allows the user to check that the board is powered up. If the voltage is present on the jack connector but the LED is off, then check the fuse F1.

Up to three evaluation boards RD33774ADSTEBV or one RD33774CNT3EVB can be connected using connectors J4, J5, and J6 with no specific order.

#### 3.3.3 Current consumption

The slider pack should be supplied with a +5 V AC-DC adapter or with a lab supply. The required supply current depends on several parameters described below.

With no board connected, the default supply current on the 5 V primary is around 500 mA [19 × 28 mA (DC-DC typ supply current)].

One RD33774ADSTEBV board, communicating, no balancing activated, consumes around 10.5 mA. Then the total supply current required on the 5 V primary is around 700 mA [500 mA + (19 × 10.5 mA)].

If three boards are connected, then the supply current is 500 mA + (3 × 19 × 10.5 mA) = 1 A.

If cell balancing is activated, the primary current depends on the cell voltage, the balancing resistance, and the number of balancing metal-oxide-semiconductor field-effect transistor (MOSFET) activated.

On RD33774ADSTEBV, the balancing resistance is 22 Ω per cell balancing channel. With  $V_{cell} = 3.3\text{ V}$ , the peak balancing current is 150 mA peak, 75 mA average assuming a 50 % duty cycle. If N cell balancing MOSFETs are activated, then  $N \times 75\text{ mA}$  are added to the primary current needed. If one board is connected and all 18 cell balancing MOSFETs are activated, then the total current is  $700\text{ mA} + 18 \times 75\text{ mA} = 2\text{ A}$ . Each individual channel (200 mA of current capability) has to provide 10.5 mA + 75 mA averaged or 10.5 mA + 150 mA peak.

**Note:** The current is limited to 180 mA per channel. If several boards are connected, it is recommended to avoid to activate same cell balancing channels at the same time on all the boards.

### 3.3.4 Cell polarity selection

Three pairs of jumpers allow the polarity to be reversed for cell polarities for cell4 (C5M – C4M), cell8 (C9M – C8M) and cell13 (C14M – C13M) therefore providing voltages between -1.2 V and -3.3 V; see [Table 3](#).

Table 3. Cell voltage polarity selection

Cell polarity	Jumper positions
Cell4 positive polarity (default)	J7 1-2 (C4M) and J8 1-2 (C5M)
Cell4 negative polarity	J7 2-3 (C4M) and J8 2-3 (C5M)
Cell8 positive polarity (default)	J10 1-2 (C8M) and J9 1-2 (C9M)
Cell8 negative polarity	J10 2-3 (C8M) and J9 2-3 (C9M)
Cell13 positive voltage (default)	J11 1-2 (C14M) and J12 1-2 (C13M)
Cell13 negative voltage	J11 2-3 (C14M) and J12 2-3 (C13M)

**Note:** Jumper selections should be done prior to supplying the BATT-18EMULATOR. Adjacent cell voltages are impacted when changing the polarities.

### 3.3.5 External voltage injection

The three jumpers can also be used as injection points to inject voltages above slider ranges:  $-1.2\text{ V} < V_{inj} < +1.2\text{ V}$  or  $3.3\text{ V} < V_{inj}$ , typically to evaluate MC33774 cell terminal measurements at very low voltage (busbars) or a high-voltage cell.

As example, to inject a voltage between C5M and C4M, remove jumper J8, keep jumper J7 1-2, and connect a floating supply between J8-2 and J7-1 or 2. Do not exceed maximum ratings and keep cell voltage in the range -5 V to +5 V.

### 3.3.6 Temperature sensor simulation

A separate slider allows the variation of the voltage across the temperature sensors.

The temperature sensor output voltage can vary from 0 V to +4.95 V. It can mimic the temperature variation from -48 °C to +200 °C of a 10 kΩ NTC sensor. This output voltage is connected to four different general-purpose input/output (GPIO) on the MC33774 (GPIO 1, 2, 7, 8) configured as ratiometric inputs with 10 kΩ pull-up resistors to VAUX (3.3 V typ.).

## 3.4 MC33774 board connections

Three 32 pins connectors (JAE Electronics MX34032NF2) J4, J5, J6 are connected in parallel as per the following schematic [Figure 3](#). Up to three boards (for example, RD33774ADSTEBV) or one board RD33774CNT3EBV can be connected on any of these connectors.

Slider cell 0 is setting the voltage between C0M (cell0M) and C1M (cell0P), slider cell 1 is setting the voltage between C1M (cell1M) and C2M (cell1P), and so on, slider cell 17 is setting the voltage between C17M (cell17M) and C17P (cell17P).

C17P-PWR and GND (pin 21) are used to supply the RD33774ADSTEBV and are separated from C17P and C0M respectively to avoid any voltage drop due to the current consumption of the evaluation boards.

The slide temperature sensor is connected on pin 17 to pin 20 (NTC1, 2, 7 and 8 for RD33774DSTEBV).

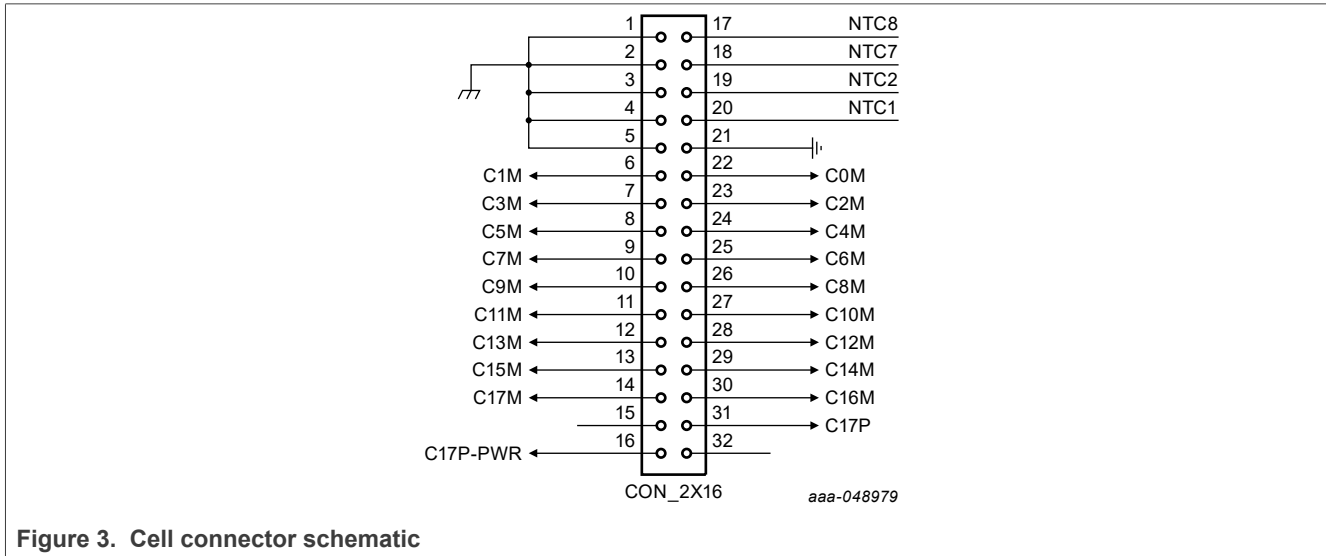

Figure 3. Cell connector schematic



Figure 4. BATT-18EMULATOR connected to three RD33774DSTEBV

### 4 Schematic

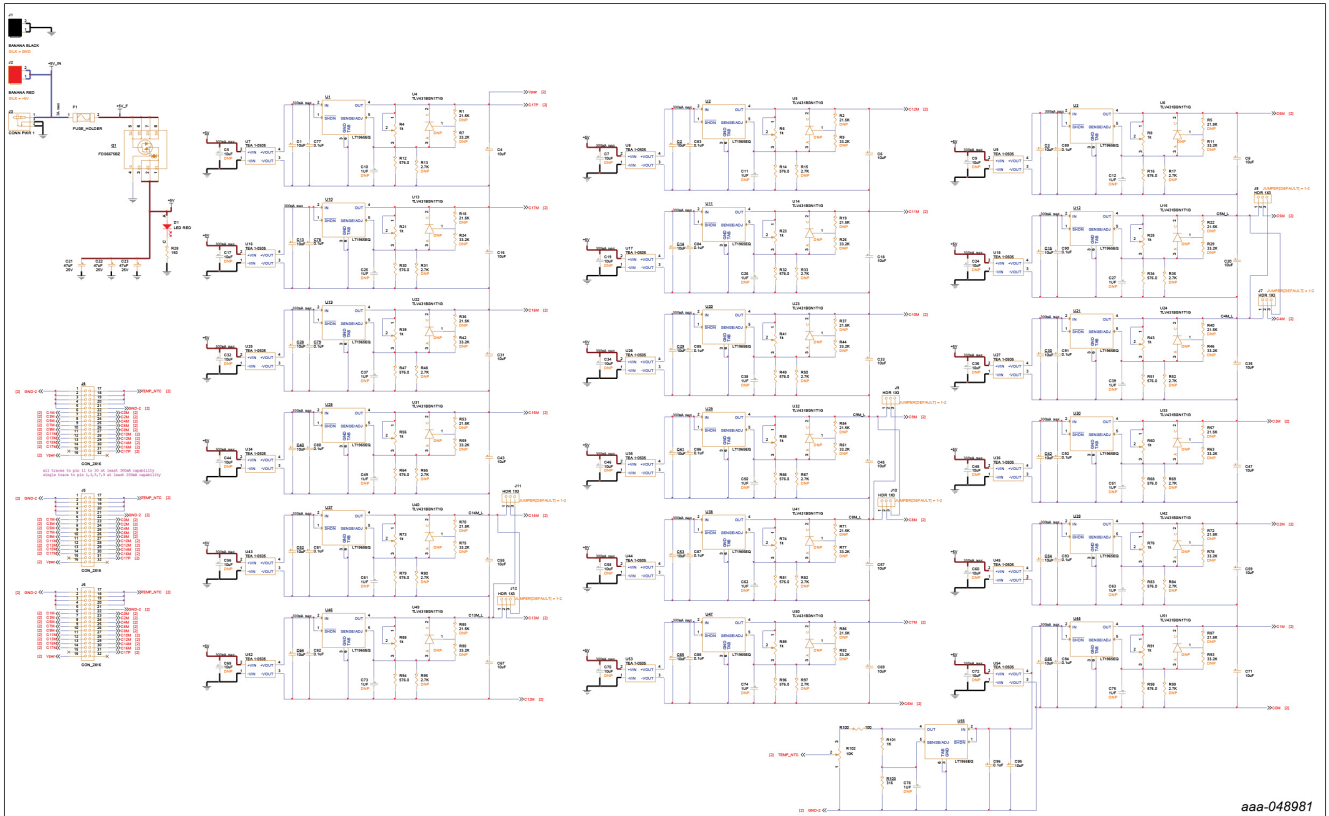

Figure 5. Schema



## 5 Legal information

### 5.1 Definitions

**Draft** — A draft status on a document indicates that the content is still under internal review and subject to formal approval, which may result in modifications or additions. NXP Semiconductors does not give any representations or warranties as to the accuracy or completeness of information included in a draft version of a document and shall have no liability for the consequences of use of such information.

### 5.2 Disclaimers

**Limited warranty and liability** — Information in this document is believed to be accurate and reliable. However, NXP Semiconductors does not give any representations or warranties, expressed or implied, as to the accuracy or completeness of such information and shall have no liability for the consequences of use of such information. NXP Semiconductors takes no responsibility for the content in this document if provided by an information source outside of NXP Semiconductors.

In no event shall NXP Semiconductors be liable for any indirect, incidental, punitive, special or consequential damages (including - without limitation - lost profits, lost savings, business interruption, costs related to the removal or replacement of any products or rework charges) whether or not such damages are based on tort (including negligence), warranty, breach of contract or any other legal theory.

Notwithstanding any damages that customer might incur for any reason whatsoever, NXP Semiconductors' aggregate and cumulative liability towards customer for the products described herein shall be limited in accordance with the Terms and conditions of commercial sale of NXP Semiconductors.

**Right to make changes** — NXP Semiconductors reserves the right to make changes to information published in this document, including without limitation specifications and product descriptions, at any time and without notice. This document supersedes and replaces all information supplied prior to the publication hereof.

**Applications** — Applications that are described herein for any of these products are for illustrative purposes only. NXP Semiconductors makes no representation or warranty that such applications will be suitable for the specified use without further testing or modification.

Customers are responsible for the design and operation of their applications and products using NXP Semiconductors products, and NXP Semiconductors accepts no liability for any assistance with applications or customer product design. It is customer's sole responsibility to determine whether the NXP Semiconductors product is suitable and fit for the customer's applications and products planned, as well as for the planned application and use of customer's third party customer(s). Customers should provide appropriate design and operating safeguards to minimize the risks associated with their applications and products.

NXP Semiconductors does not accept any liability related to any default, damage, costs or problem which is based on any weakness or default in the customer's applications or products, or the application or use by customer's third party customer(s). Customer is responsible for doing all necessary testing for the customer's applications and products using NXP Semiconductors products in order to avoid a default of the applications and the products or of the application or use by customer's third party customer(s). NXP does not accept any liability in this respect.

**Terms and conditions of commercial sale** — NXP Semiconductors products are sold subject to the general terms and conditions of commercial sale, as published at <http://www.nxp.com/profile/terms>, unless otherwise agreed in a valid written individual agreement. In case an individual agreement is concluded only the terms and conditions of the respective agreement shall apply. NXP Semiconductors hereby expressly objects to applying the customer's general terms and conditions with regard to the purchase of NXP Semiconductors products by customer.

**Suitability for use in automotive applications** — This NXP product has been qualified for use in automotive applications. If this product is used by customer in the development of, or for incorporation into, products or services (a) used in safety critical applications or (b) in which failure could lead to death, personal injury, or severe physical or environmental damage (such products and services hereinafter referred to as "Critical Applications"), then customer makes the ultimate design decisions regarding its products and is solely responsible for compliance with all legal, regulatory, safety, and security related requirements concerning its products, regardless of any information or support that may be provided by NXP. As such, customer assumes all risk related to use of any products in Critical Applications and NXP and its suppliers shall not be liable for any such use by customer. Accordingly, customer will indemnify and hold NXP harmless from any claims, liabilities, damages and associated costs and expenses (including attorneys' fees) that NXP may incur related to customer's incorporation of any product in a Critical Application.

**Export control** — This document as well as the item(s) described herein may be subject to export control regulations. Export might require a prior authorization from competent authorities.

**Evaluation products** — This product is provided on an "as is" and "with all faults" basis for evaluation purposes only. NXP Semiconductors, its affiliates and their suppliers expressly disclaim all warranties, whether express, implied or statutory, including but not limited to the implied warranties of non-infringement, merchantability and fitness for a particular purpose. The entire risk as to the quality, or arising out of the use or performance, of this product remains with customer.

In no event shall NXP Semiconductors, its affiliates or their suppliers be liable to customer for any special, indirect, consequential, punitive or incidental damages (including without limitation damages for loss of business, business interruption, loss of use, loss of data or information, and the like) arising out of the use of or inability to use the product, whether or not based on tort (including negligence), strict liability, breach of contract, breach of warranty or any other theory, even if advised of the possibility of such damages.

Notwithstanding any damages that customer might incur for any reason whatsoever (including without limitation, all damages referenced above and all direct or general damages), the entire liability of NXP Semiconductors, its affiliates and their suppliers and customer's exclusive remedy for all of the foregoing shall be limited to actual damages incurred by customer based on reasonable reliance up to the greater of the amount actually paid by customer for the product or five dollars (US\$5.00). The foregoing limitations, exclusions and disclaimers shall apply to the maximum extent permitted by applicable law, even if any remedy fails of its essential purpose.

**Translations** — A non-English (translated) version of a document, including the legal information in that document, is for reference only. The English version shall prevail in case of any discrepancy between the translated and English versions.

**Security** — Customer understands that all NXP products may be subject to unidentified vulnerabilities or may support established security standards or specifications with known limitations. Customer is responsible for the design and operation of its applications and products throughout their lifecycles to reduce the effect of these vulnerabilities on customer's applications and products. Customer's responsibility also extends to other open and/or proprietary technologies supported by NXP products for use in customer's applications. NXP accepts no liability for any vulnerability. Customer should regularly check security updates from NXP and follow up appropriately. Customer shall select products with security features that best meet rules, regulations, and standards of the intended application and make the ultimate design decisions regarding its products and is solely responsible for compliance with all legal, regulatory, and security related requirements concerning its products, regardless of any information or support that may be provided by NXP.

NXP has a Product Security Incident Response Team (PSIRT) (reachable at [PSIRT@nxp.com](mailto:PSIRT@nxp.com)) that manages the investigation, reporting, and solution release to security vulnerabilities of NXP products.

### 5.3 Trademarks

**NXP** — wordmark and logo are trademarks of NXP B.V.

Notice: All referenced brands, product names, service names, and trademarks are the property of their respective owners.

**Tables**

Tab. 1.	Limiting values .....	4	Tab. 3.	Cell voltage polarity selection .....	6
Tab. 2.	Electrical characteristics .....	4			

**Figures**

Fig. 1.	BATT-18EMULATOR .....	3	Fig. 4.	BATT-18EMULATOR connected to three RD33774DSTEVB .....	7
Fig. 2.	BATT-18EMULATOR board elements .....	5	Fig. 5.	Schema .....	8
Fig. 3.	Cell connector schematic .....	7			