



UM11124

Introduction to 6-cell and 14-cell slider battery pack emulator kit

Rev. 1 — 16 May 2018

User manual

Document information

Information	Content
Keywords	battery cell controller, battery emulator, battery management systems
Abstract	This user manual provides the user with an overview of the BATT-6EMULATOR and BATT-14EMULATOR battery pack emulators.



Revision history

Rev	Date	Description
1	20180516	initial version

1 Introduction

The BATT-6EMULATOR and BATT-14EMULATOR boards can emulate a multi-cell battery pack that can be easily hooked-up to the evaluation boards for MC33771 and MC33772 battery cell controllers (BCC):

- FRDM33772BTPEVB (to be used with BATT-6EMULATOR)
- FRDM33772BSPIEBV (to be used with BATT-6EMULATOR)
- FRDM33771BTPEVB (to be used with BATT-14EMULATOR)
- FRDM33771BSPIEBV (to be used with BATT-14EMULATOR)

The user can connect the BATT-6EMULATOR and BATT-14EMULATOR boards for a quick evaluation of NXP BCC ICs, or to help the users in their software development. These boards basically provide a very intuitive way to change the voltage across any of the 6 cells or 14 cells of an emulated battery pack as well as the voltage across an emulated current sense shunt resistor.

2 Specifications

These boards have been designed and optimized for the operating conditions described below. Usage of these boards beyond these conditions can lead to malfunction and damage.

Table 1. Maximum ratings

Description	Min	Max	Unit
Supply input voltage	10.8	13.2	V
Cell output current	-	110	mA
Current sense output current	-	±1	µA
Operating ambient temperature	-10	+40	°C

Table 2. Electrical characteristics

Description	Min	Typ	Max	Unit
Minimum cell voltage output (slider down)	-	1.25	-	V
Maximum cell voltage output (slider up)	-	4.6	-	V
Minimum current sensor voltage output (slider down)	-	-150	-	mV
Maximum current sensor voltage output (slider up)	-	150	-	mV
Voltage isolation between input power supply and battery emulator outputs	-	1	-	kV

3 Pack content

The kit includes:

One electronic board: The slider battery pack emulator board itself further referenced in this document as emulator board.

One ribbon cable that allows the user to connect the slider battery pack emulator to the MC3377x evaluation kits.

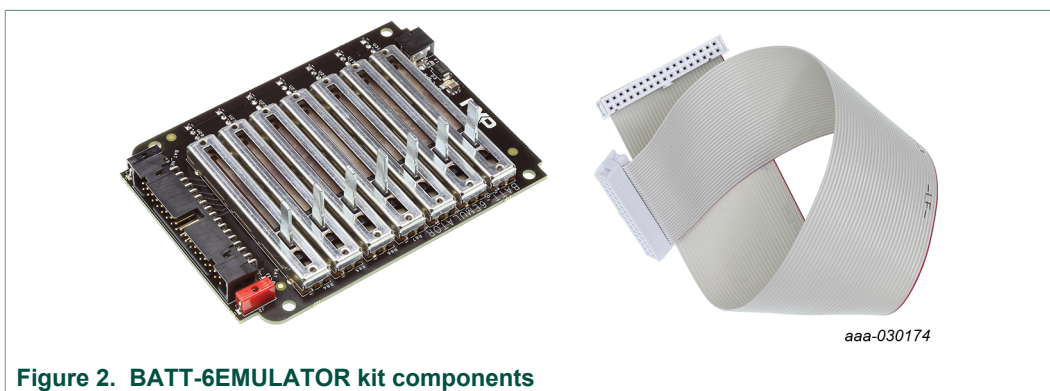
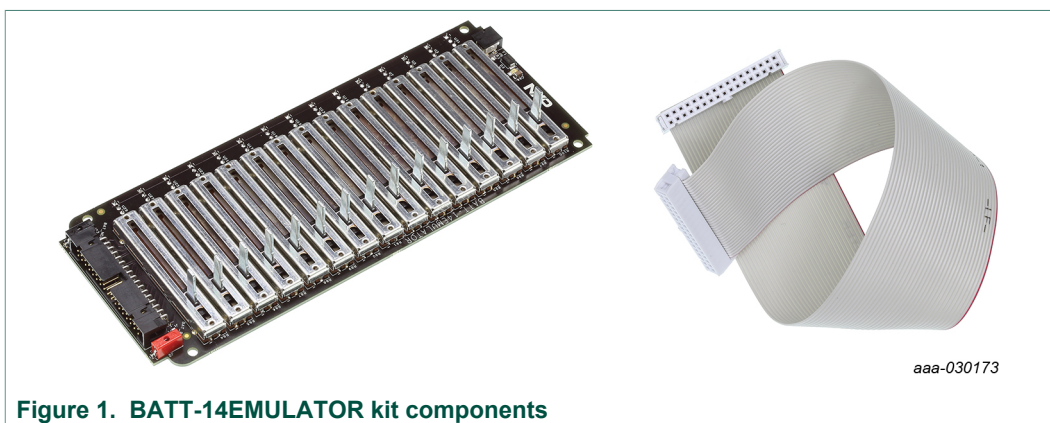

4 Getting started with the emulator board

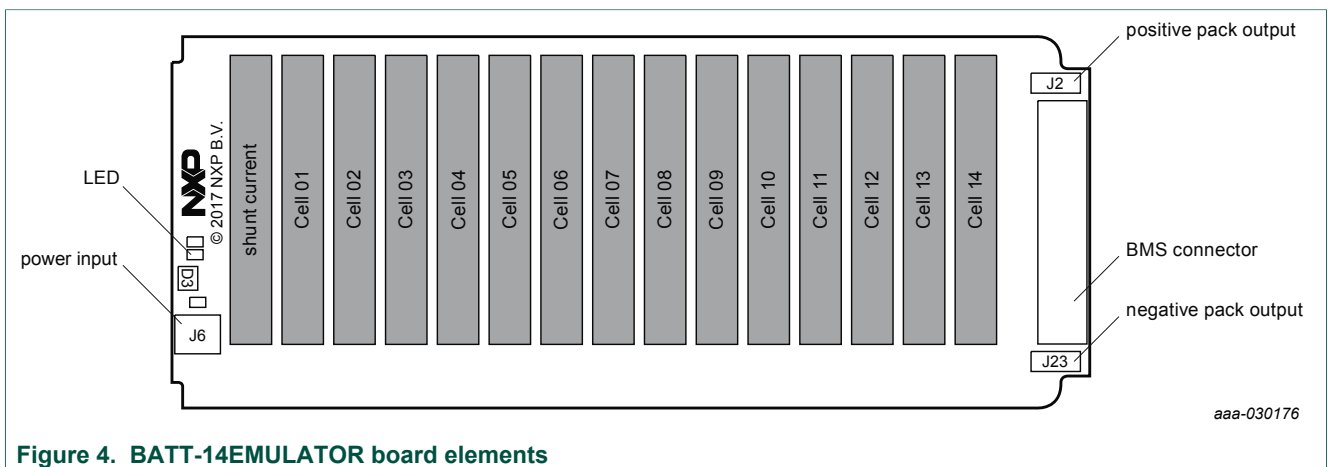
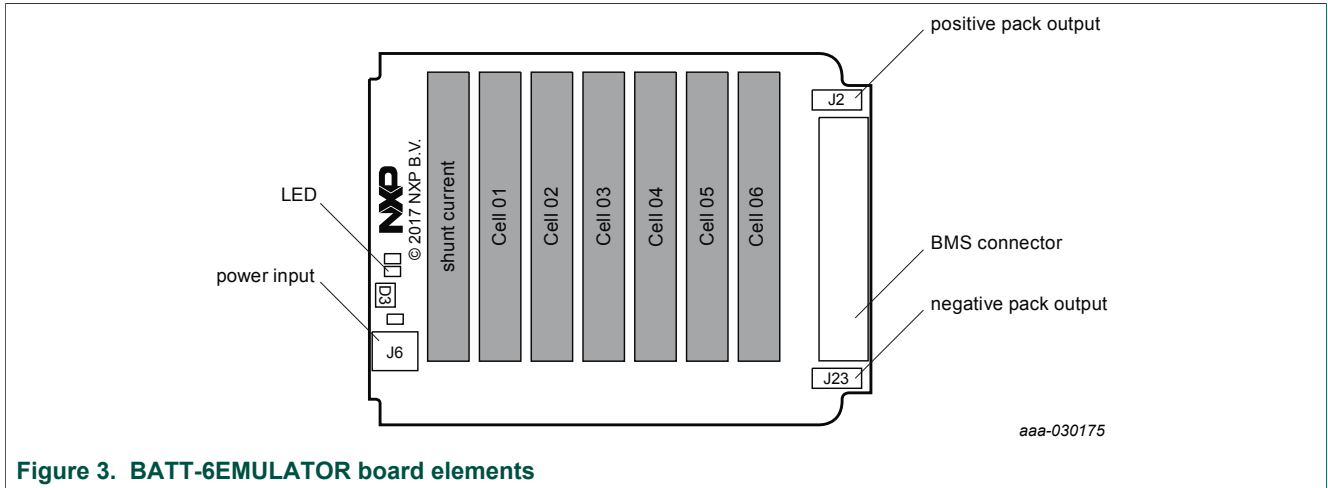

The emulator board requires a 12 V DC power supply with 1.5 A current capability (1 A is enough for BATT-6EMULATOR). The power supply is to be connected to the board via J6, a Ø3.5 mm jack connector. The center pin is to be connected to the positive voltage and the ring terminal to the ground. The input of the board is protected in case of wrong polarity. An LED allows the user to check that the board is powered up. If the voltage is present to the jack connector but the LED is off, then check the fuse F1.

Each of the sliders allows the user to change independently the differential voltage between two cell terminals (or cell voltage). A separate slider allows the variation of the voltage across the current shunt resistor.

Using the slider potentiometers, the user can modify each cell voltage between 1.25 V and 4.6 V. The current capability of the cell output voltage is 110 mA which allows the user to connect up to three evaluation boards in parallel.

The current sense output voltage can vary from -150 mV to +150 mV. This output is not designed to drive a large current since the current sense input from the MC3377x needs as little as 100 nA. If more than 1 µA is pulled from this output, the voltage may drop by a few mV.

The emulator board features two output terminals, a red and a black 2 mm banana plug. The plugs can be used to connect several emulator boards in series. The isolation voltage between the power input and the cells is higher than 1000 V. If several emulator boards are connected in series, the voltage of the packs may exceed 75 V. The user has to take adequate precautions related to the high-voltage risks.

5 Schematics

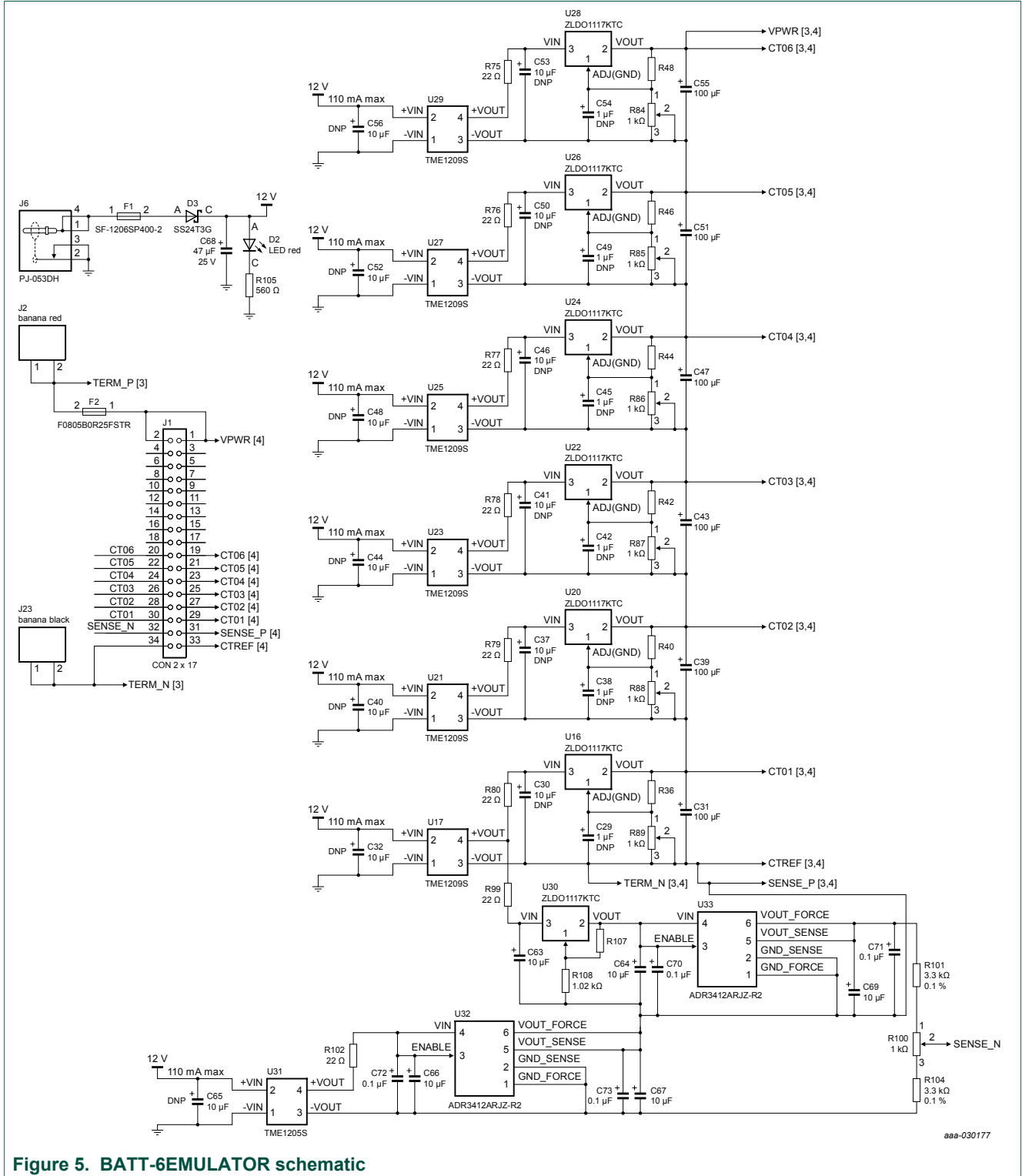

Introduction to 6-cell and 14-cell slider battery pack emulator kit

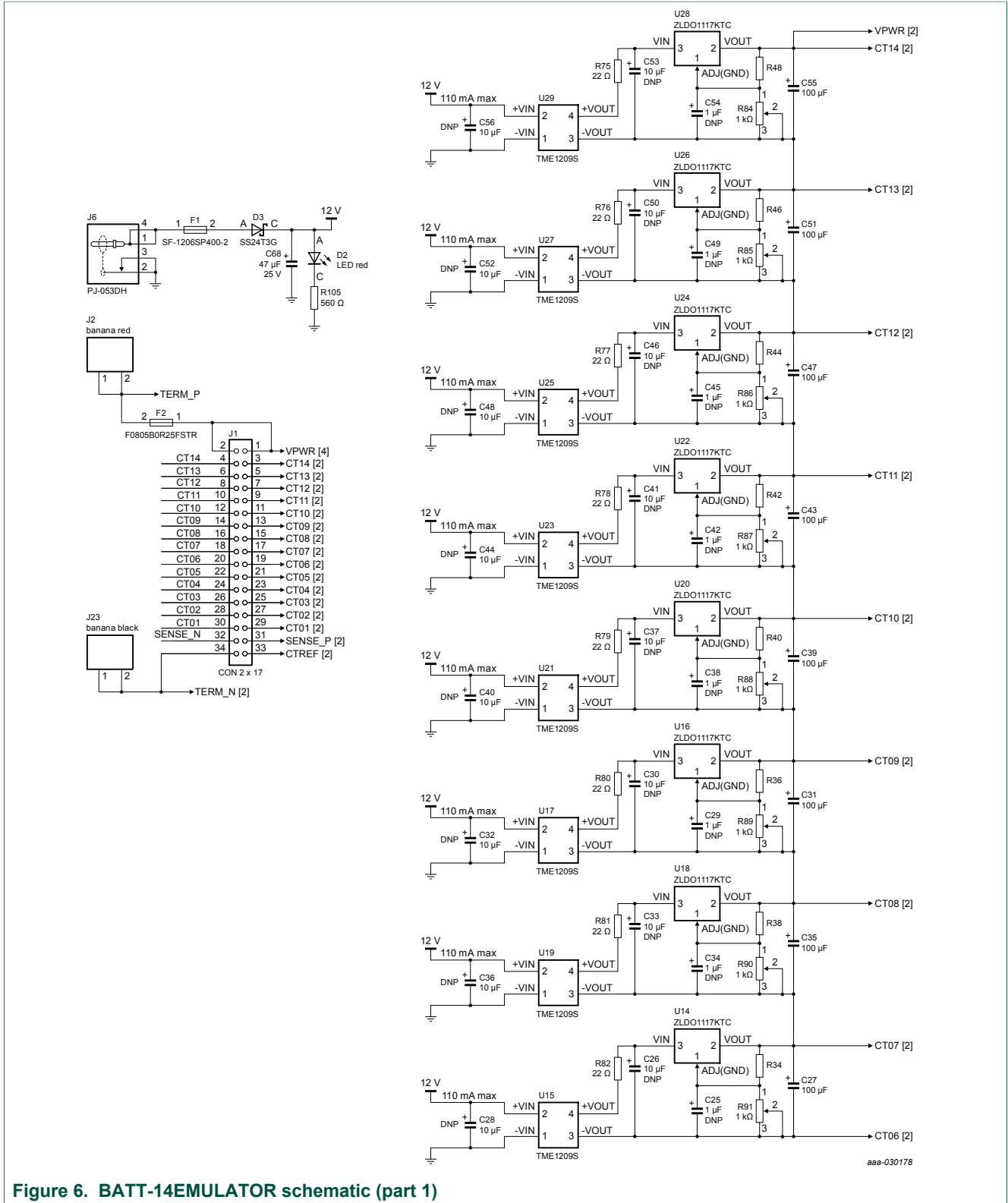

Introduction to 6-cell and 14-cell slider battery pack emulator kit

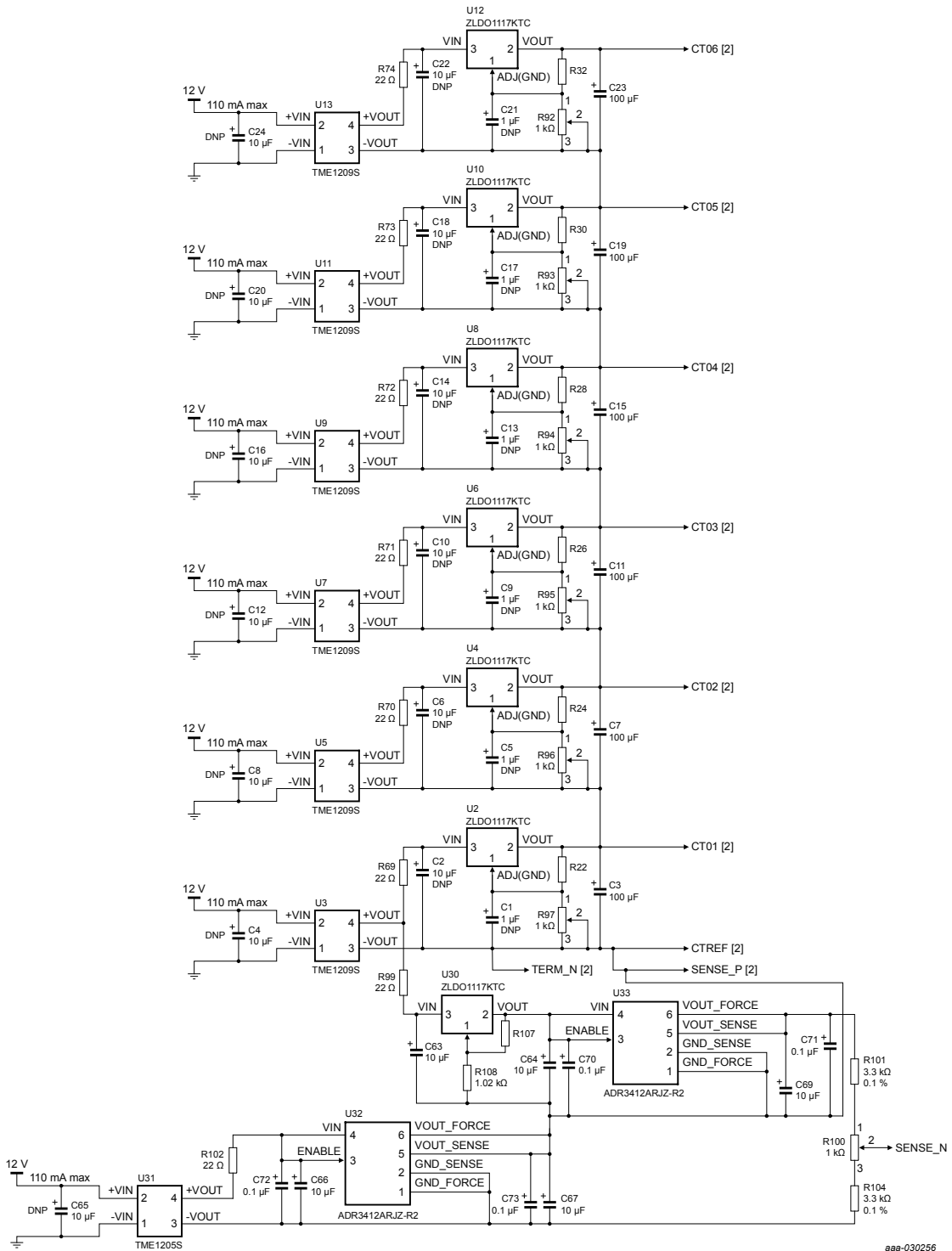

Figure 7. BATT-14EMULATOR schematic (part 2)

6 Board bill of materials

Table 3. BATT-6EMULATOR bill of materials

NXP does not assume liability, endorse, or warrant components from external manufacturers are referenced in circuit drawings or tables. While NXP offers component recommendations in this configuration, it is the responsibility of the customer to validate.

Item	Qty	Assembly option	Reference	Value	Manufacturing part number	Description
1	6	DNP	C29, C38, C42, C45, C49, C54	1 μ F		50 V capacitor 1206
2	13	DNP	C30, C32, C37, C40, C41, C44, C46, C48, C50, C52, C53, C56, C65	10 μ F		50 V capacitor 1206
3	6		C31, C39, C43, C47, C51, C55	100 μ F		10 V capacitor 1206
4	5		C63, C64, C66, C67, C69	10 μ F		50 V capacitor 1206
5	1		C68	47 μ F		25 V capacitor 1206
6	4		C70, C71, C72, C73	0.1 μ F		50 V capacitor 0603
7	1		D2		APT3216SURCK	LED red
8	1		D3	40 V	SS24T3G	diode 2 A 40 V SMB
9	1		F1	4 A	SF-1206SP400-2	fuse 4 A SMD 1206
10	1		F2	0.25 A	F0805B0R25FSTR	fuse 0.25 A SMD 0805
11	1		J1		N2534-5002-RB	CON 2X17
12	1		J2		930224101	banana red
13	1		J6		PJ-053DH	PWR jack 1.3 mm
14	1		J23		930224100	banana black
15	7		R36, R40, R42, R44, R46, R48, R107	340 Ω		RES 0.125 W 1 % 0603
16	8		R75, R76, R77, R78, R79, R80, R99, R102	22 Ω		RES 0.25 W 5 % 1206
17	7		R84, R85, R86, R87, R88, R89, R100	1 k Ω	PTA4543-2015CPB 102	RES POT 1 k Ω 0.25 W
18	2		R101, R104	3.3 k Ω		RES 0.1 W 0.1 % 0603
19	1		R105	560 Ω		RES 0.125 W 1 % 0603
20	1		R108	1.02 k Ω		RES 0.1 W 1 % 0603
21	7		U16, U20, U22, U24, U26, U28, U30		ZLDO1117KTC	voltage regulator
22	6		U17, U21, U23, U25, U27, U29		TME1209S	9 V DC-to-DC converter
23	1		U31		TME1205S	5 V DC-to-DC converter
24	2		U32, U33		ADR3412ARJZ-R2	voltage reference 1.2 V

Introduction to 6-cell and 14-cell slider battery pack emulator kit

Table 4. BATT-14EMULATOR bill of materials

NXP does not assume liability, endorse, or warrant components from external manufacturers are referenced in circuit drawings or tables. While NXP offers component recommendations in this configuration, it is the responsibility of the customer to validate.

Item	Qty	Assembly option	Reference	Value	Manufacturing part number	Description
1	14	DNP	C1, C5, C9, C13, C17, C21, C25, C29, C34, C38, C42, C45, C49, C54	1 μ F		50 V capacitor 1206
2	29	DNP	C2, C4, C6, C8, C10, C12, C14, C16, C18, C20, C22, C24, C26, C28, C30, C32, C33, C36, C37, C40, C41, C44, C46, C48, C50, C52, C53, C56, C65	10 μ F		50 V capacitor 1206
3	14		C3, C7, C11, C15, C19, C23, C27, C31, C35, C39, C43, C47, C51, C55	100 μ F		10 V capacitor 1206
4	5		C63, C64, C66, C67, C69	10 μ F		50 V capacitor 1206
5	1		C68	47 μ F		25 V capacitor 1206
6	4		C70, C71, C72, C73	0.1 μ F		50 V capacitor 0603
7	1		D2		APT3216SURCK	LED red
8	1		D3	40 V	SS24T3G	diode 2 A 40 V SMB
9	1		F1	4 A	SF-1206SP400-2	fuse 4 A SMD 1206
10	1		F2	0.25 A	F0805B0R25FSTR	fuse 0.25 A SMD 0805
11	1		J1		N2534-5002-RB	CON 2X17
12	1		J2		930224101	banana red
13	1		J6		PJ-053DH	PWR jack 1.3 mm
14	1		J23		930224100	banana black
15	15		R22, R24, R26, R28, R30, R32, R34, R36, R38, R40, R42, R44, R46, R48, R107	340 Ω		RES 0.125 W 1 % 0603
16	16		R69, R70, R71, R72, R73, R74, R75, R76, R77, R78, R79, R80, R81, R82, R99, R102	22 Ω		RES 0.25 W 5 % 1206
17	15		R84, R85, R86, R87, R88, R89, R90, R91, R92, R93, R94, R95, R96, R97, R100	1 k Ω	PTA4543-2015CPB 102	RES POT 1 k Ω 0.25 W
18	2		R101, R104	3.3 k Ω		RES 0.1 W 0.1 % 0603
19	1		R105	560 Ω		RES 0.125 W 1 % 0603
20	1		R108	1.02 k Ω		RES 0.1 W 1 % 0603
21	15		U2, U4, U6, U8, U10, U12, U14, U16, U18, U20, U22, U24, U26, U28, U30		ZLDO1117KTC	voltage regulator
22	14		U3, U5, U7, U9, U11, U13, U15, U17, U19, U21, U23, U25, U27, U29		TME1209S	9 V DC-to-DC converter

Item	Qty	Assembly option	Reference	Value	Manufacturing part number	Description
23	1		U31		TME1205S	5 V DC-to-DC converter
24	2		U32, U33		ADR3412ARJZ-R2	voltage reference 1.2 V

7 References

The following are URLs where the user can obtain information on related NXP products and application solutions.

Table 5. References

Item	Description	Link
BATT-6EMULATOR	tool summary page	http://www.nxp.com/BATT-6EMULATOR
BATT-14EMULATOR	tool summary page	http://www.nxp.com/BATT-14EMULATOR
MC33771 MC33772	battery cell controllers page	http://www.nxp.com/Battery-Cell-Controllers
FRDM33771BSPIEBV	evaluation kit	http://www.nxp.com/FRDM33771BSPIEBV
FRDM33771BTPLEVB	evaluation kit	http://www.nxp.com/FRDM33771BTPLEVB
FRDM33772BSPIEBV	evaluation kit	http://www.nxp.com/FRDM33772BSPIEBV
FRDM33772BTPLEVB	evaluation kit	http://www.nxp.com/FRDM33772BTPLEVB

8 Legal information

8.1 Definitions

Draft — The document is a draft version only. The content is still under internal review and subject to formal approval, which may result in modifications or additions. NXP Semiconductors does not give any representations or warranties as to the accuracy or completeness of information included herein and shall have no liability for the consequences of use of such information.

8.2 Disclaimers

Limited warranty and liability — Information in this document is believed to be accurate and reliable. However, NXP Semiconductors does not give any representations or warranties, expressed or implied, as to the accuracy or completeness of such information and shall have no liability for the consequences of use of such information. NXP Semiconductors takes no responsibility for the content in this document if provided by an information source outside of NXP Semiconductors. In no event shall NXP Semiconductors be liable for any indirect, incidental, punitive, special or consequential damages (including - without limitation - lost profits, lost savings, business interruption, costs related to the removal or replacement of any products or rework charges) whether or not such damages are based on tort (including negligence), warranty, breach of contract or any other legal theory. Notwithstanding any damages that customer might incur for any reason whatsoever, NXP Semiconductors' aggregate and cumulative liability towards customer for the products described herein shall be limited in accordance with the Terms and conditions of commercial sale of NXP Semiconductors.

Right to make changes — NXP Semiconductors reserves the right to make changes to information published in this document, including without limitation specifications and product descriptions, at any time and without notice. This document supersedes and replaces all information supplied prior to the publication hereof.

Applications — Applications that are described herein for any of these products are for illustrative purposes only. NXP Semiconductors makes no representation or warranty that such applications will be suitable for the specified use without further testing or modification. Customers are responsible for the design and operation of their applications and products using NXP Semiconductors products, and NXP Semiconductors accepts no liability for any assistance with applications or customer product design. It is customer's sole responsibility to determine whether the NXP Semiconductors product is suitable and fit for the customer's applications and products planned, as well as for the planned application and use of customer's third party customer(s). Customers should provide appropriate design and operating safeguards to minimize the risks associated with their applications and products. NXP Semiconductors does not accept any liability related to any default, damage, costs or problem which is based on any weakness or default in the customer's applications or products, or the application or use by customer's third party customer(s). Customer is responsible for doing all necessary testing for the customer's applications and products using NXP Semiconductors products in order to avoid a default of the applications and the products or of the application or use by customer's third party customer(s). NXP does not accept any liability in this respect.

Suitability for use in automotive applications — This NXP Semiconductors product has been qualified for use in automotive applications. Unless otherwise agreed in writing, the product is not designed, authorized or warranted to be suitable for use in life support, life-critical or

safety-critical systems or equipment, nor in applications where failure or malfunction of an NXP Semiconductors product can reasonably be expected to result in personal injury, death or severe property or environmental damage. NXP Semiconductors and its suppliers accept no liability for inclusion and/or use of NXP Semiconductors products in such equipment or applications and therefore such inclusion and/or use is at the customer's own risk.

Export control — This document as well as the item(s) described herein may be subject to export control regulations. Export might require a prior authorization from competent authorities.

Evaluation products — This product is provided on an "as is" and "with all faults" basis for evaluation purposes only. NXP Semiconductors, its affiliates and their suppliers expressly disclaim all warranties, whether express, implied or statutory, including but not limited to the implied warranties of non-infringement, merchantability and fitness for a particular purpose. The entire risk as to the quality, or arising out of the use or performance, of this product remains with customer. In no event shall NXP Semiconductors, its affiliates or their suppliers be liable to customer for any special, indirect, consequential, punitive or incidental damages (including without limitation damages for loss of business, business interruption, loss of use, loss of data or information, and the like) arising out of the use of or inability to use the product, whether or not based on tort (including negligence), strict liability, breach of contract, breach of warranty or any other theory, even if advised of the possibility of such damages. Notwithstanding any damages that customer might incur for any reason whatsoever (including without limitation, all damages referenced above and all direct or general damages), the entire liability of NXP Semiconductors, its affiliates and their suppliers and customer's exclusive remedy for all of the foregoing shall be limited to actual damages incurred by customer based on reasonable reliance up to the greater of the amount actually paid by customer for the product or five dollars (US\$5.00). The foregoing limitations, exclusions and disclaimers shall apply to the maximum extent permitted by applicable law, even if any remedy fails of its essential purpose.

Safety of high-voltage evaluation products — The non-insulated high voltages that are present when operating this product, constitute a risk of electric shock, personal injury, death and/or ignition of fire. This product is intended for evaluation purposes only. It shall be operated in a designated test area by personnel that is qualified according to local requirements and labor laws to work with non-insulated mains voltages and high-voltage circuits. The product does not comply with IEC 60950 based national or regional safety standards. NXP Semiconductors does not accept any liability for damages incurred due to inappropriate use of this product or related to non-insulated high voltages. Any use of this product is at customer's own risk and liability. The customer shall fully indemnify and hold harmless NXP Semiconductors from any liability, damages and claims resulting from the use of the product.

Translations — A non-English (translated) version of a document is for reference only. The English version shall prevail in case of any discrepancy between the translated and English versions.

8.3 Trademarks

Notice: All referenced brands, product names, service names and trademarks are the property of their respective owners.

SafeAssure — is a trademark of NXP B.V.

SMARTMOS — is a trademark of NXP B.V.