

PART NAME	SHOWCASE	PART No.	BB-1800 thru BB-1809	REV. DATE	7-17-12
-----------	----------	----------	----------------------	-----------	---------

**MATERIAL:**  
CORNER GUSSETS \_\_\_\_\_ 16 GA. STEEL  
FRONT PANEL \_\_\_\_\_ 0.090 ALUMINUM  
SHELF, COVER, REAR PANEL AND SHELF GUSSETS \_\_\_\_\_ 0.050 ALUMINUM  
FRAME \_\_\_\_\_ 6063-T42 ALUMINUM EXTRUSION  
BAIL \_\_\_\_\_ 0.125 DIAMETER SPRING WIRE  
FEET \_\_\_\_\_ NYLON  
HANDLE \_\_\_\_\_ VINYL WRAPPED STEEL

**FINISH:**  
COVER AND PANELS \_\_\_\_\_ ROYAL BLUE TEXTURE  
\_\_\_\_\_ BLACK TEXTURE  
SHELF ASSEMBLY \_\_\_\_\_ WHITE TEXTURE  
HANDLE AND FEET \_\_\_\_\_ WHITE  
HANDLE CAPS \_\_\_\_\_ NICKEL PLATED  
BAIL \_\_\_\_\_ CHROME PLATED

**NOTE:**  
MAXIMUM WEIGHT FOR HANDLE IS 25 LBS.

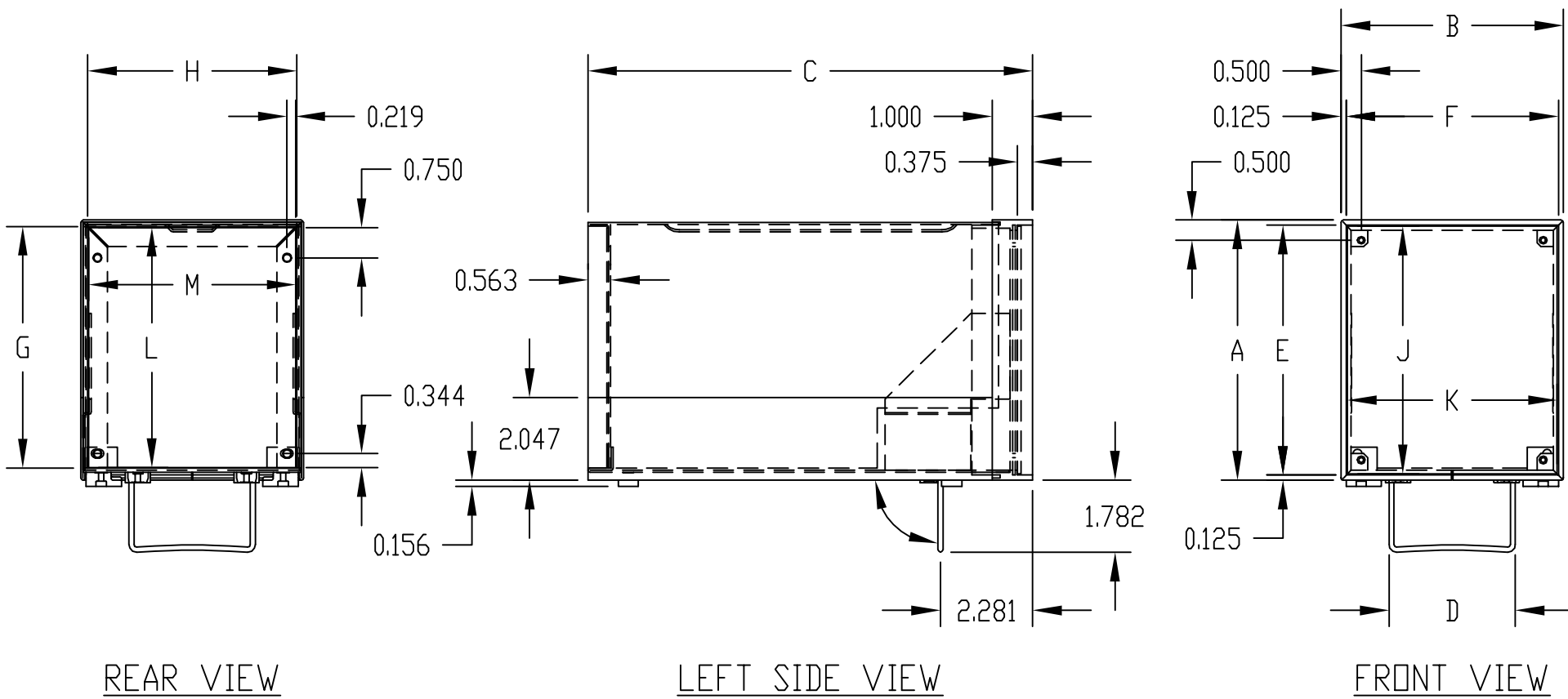
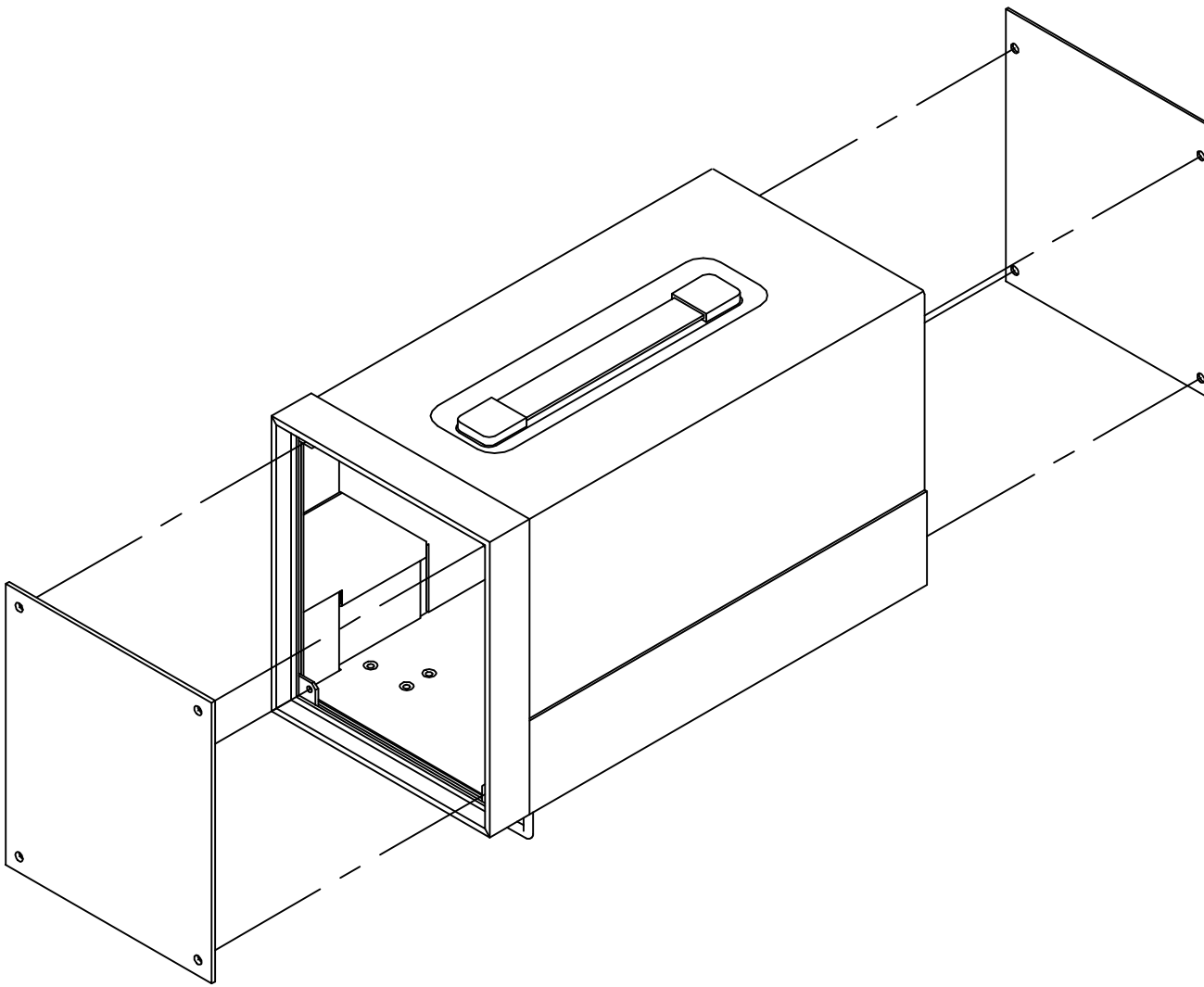

PART NUMBER	OVERALL				PANEL SPACE				PANELS				INSIDE		
	A	B	C	D	FRONT		REAR		FRONT		REAR		HEIGHT	WIDTH	DEPTH
					E	F	G	H	J	K	L	M			
BB-1800	6.438	5.500	11.000	3.125	6.188	5.250	5.978	5.175	6.125	5.188	5.938	5.125	5.938	5.000	10.000
BB-1801	6.438	8.313	11.000	5.938	6.188	8.047	5.978	7.972	6.125	7.984	5.938	7.922	5.938	7.797	10.000
BB-1802	8.188	5.500	11.000	3.125	7.938	5.250	7.728	5.175	7.875	5.188	7.688	5.125	7.688	5.000	10.000
BB-1803	8.188	8.313	11.000	5.938	7.938	8.047	7.728	7.972	7.875	7.984	7.688	7.922	7.688	7.797	10.000
BB-1804	8.188	11.063	11.000	8.688	7.938	10.828	7.728	10.753	7.875	10.766	7.688	10.703	7.688	10.578	10.000
BB-1806	9.938	8.313	11.000	5.938	9.688	8.047	9.478	7.972	9.625	7.984	9.438	7.922	9.438	7.797	10.000
BB-1807	9.938	8.313	15.000	5.938	9.688	8.047	9.478	7.972	9.625	7.984	9.438	7.922	9.438	7.797	14.000
BB-1808	9.938	11.063	11.000	8.688	9.688	10.828	9.478	10.753	9.625	10.766	9.438	10.703	9.438	10.578	10.000
BB-1809	9.938	11.063	15.000	8.688	9.688	10.828	9.478	10.753	9.625	10.766	9.438	10.703	9.438	10.578	14.000