

BC846W-G Thru. BC848W-G (NPN) RoHS Device

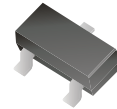

Features

- Power dissipation
PCM: 0.15W (@TA=25°C)
- Collector current
ICM: 0.1A
- Collector-base voltage
VCBO: BC846W=80V
BC847W=50V
BC848W=30V

Mechanical data

- Case: SOT-323, molded plastic.
- Terminals: solderable per MIL-STD-750, method 2026.
- Approx. weight: 0.008 grams

Circuit diagram

- 1.BASE
- 2.EMITTER
- 3.COLLECTOR

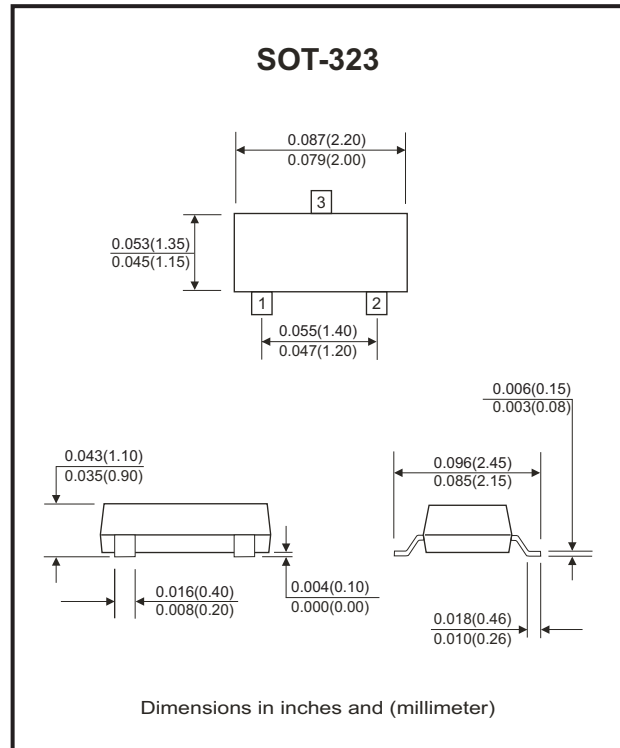
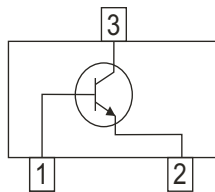

Maximum Ratings (at TA=25°C unless otherwise noted)

Parameter	Symbol	Value	Units
Collector-Base voltage	VCBO	80	V
BC847W-G		50	
BC848W-G		30	
Collector-Emitter voltage	VCEO	65	V
BC847W-G		45	
BC848W-G		30	
Emitter-Base voltage	VEBO	6	V
BC848W-G		5	
Collector current -continuous	IC	0.1	A
Collector power dissipation	PC	150	mW
Thermal resistance from junction to ambient	REJA	833	°C/W
Junction temperature range	TJ	150	°C
Storage temperature range	TSTG	-55 to +150	°C

Electrical Characteristics (at TA=25°C unless otherwise noted)

Parameter	Symbol	Test Conditions	MIN	TYP	MAX	Unit
Collector-base breakdown voltage	BC846W-G BC847W-G BC848W-G V _{CBO}	I _C = 10μA , I _E = 0	80 50 30			V
Collector-emitter breakdown voltage	BC846W-G BC847W-G BC848W-G V _{CEO}	I _C = 10mA , I _B = 0	65 45 30			V
Emitter-base break voltage	BC846W-G, BC847W-G BC848W-G V _{EBO}	I _E = 1μA , I _C = 0	6 5			V
Collector cutoff current	I _{CBO}	V _{CB} = 30V			15	nA
DC current gain	BC846AW-G, 847AW-G, 848AW-G BC846BW-G, 847BW-G, 848BW-G BC847CW-G, 848CW-G BC846AW-G, 847AW-G, 848AW-G BC846BW-G, 847BW-G, 848BW-G BC847CW-G, 848CW-G h _{FE}	V _{CE} = 5V , I _C = 10μA V _{CE} = 5V , I _C = 2mA	 110 200 420	90 150 270	 220 450 800	
Collector-emitter saturation voltage	V _{CE(sat)}	I _C = 10mA , I _B = 0.5mA I _C = 100mA , I _B = 5mA			0.25 0.60	V
Base-emitter saturation voltage	V _{BE(sat)}	I _C = 10mA , I _B = 0.5mA I _C = 100mA , I _B = 5mA		0.7 0.9		V
Base-emitter voltage	V _{BE(on)}	V _{CE} = 5V , I _C = 2mA V _{CE} = 5V , I _C = 10mA	580	660	700 770	mV
Transition frequency	f _T	V _{CE} = 5V , I _C = 10mA f = 100MHz	100			MHz
Collector output capacitance	C _{ob}	V _{CB} = 10V , f = 1MHz			4.5	pF
Noise figure	BC846AW-G, 847AW-G, 848AW-G BC846BW-G, 847BW-G, 848BW-G BC847CW-G, 848CW-G NF	V _{CE} = 5V , I _C = 0.2mA f = 1KHz , R _S = 2KΩ BW = 200Hz			10 10 4	dB

Electrical Characteristic Curves (BC846W-G Thru. BC848W-G)

Fig.1 - Static Characteristic

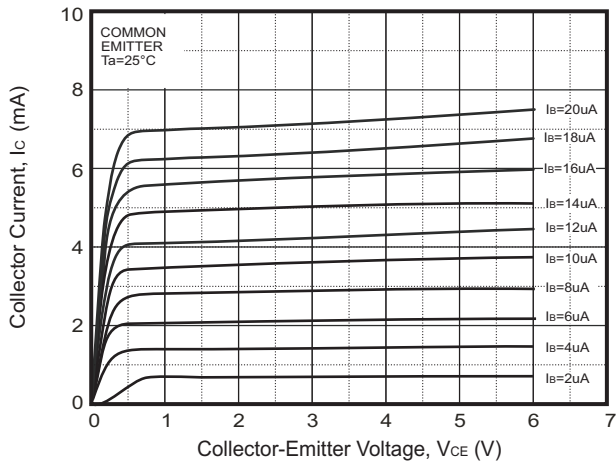

Fig.2 - $h_{FE} - I_c$

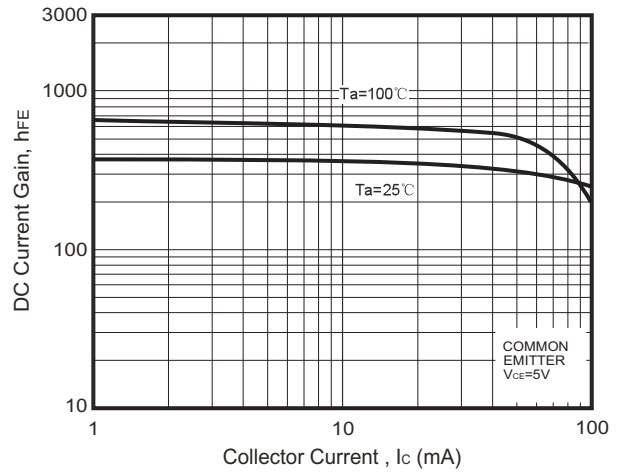

Fig.3 - $V_{BEsat} - I_c$

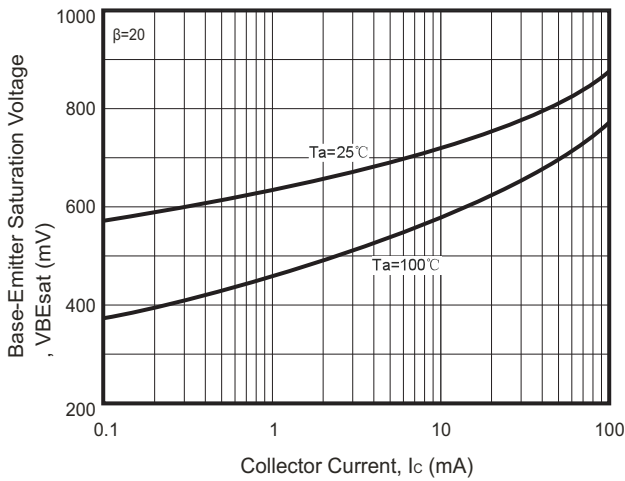

Fig.4 - $V_{CEsat} - I_c$

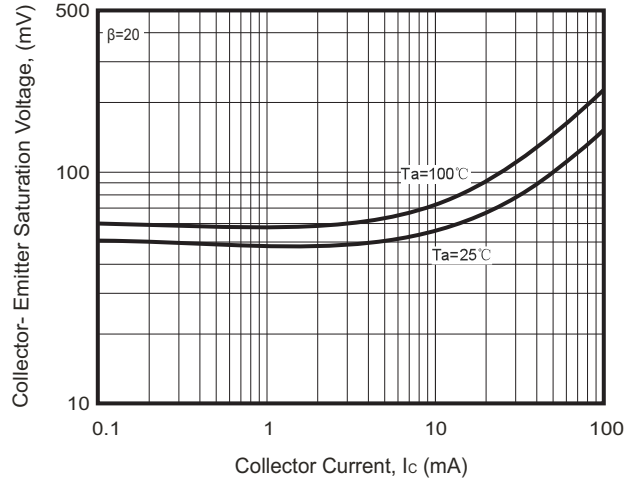

Fig.5 - $I_c - V_{BE}$

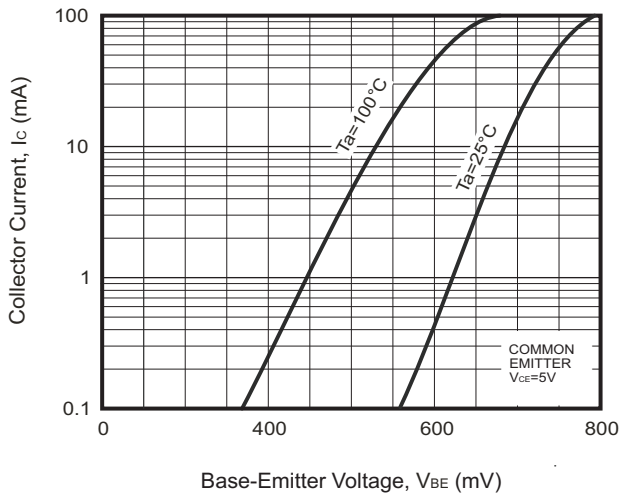
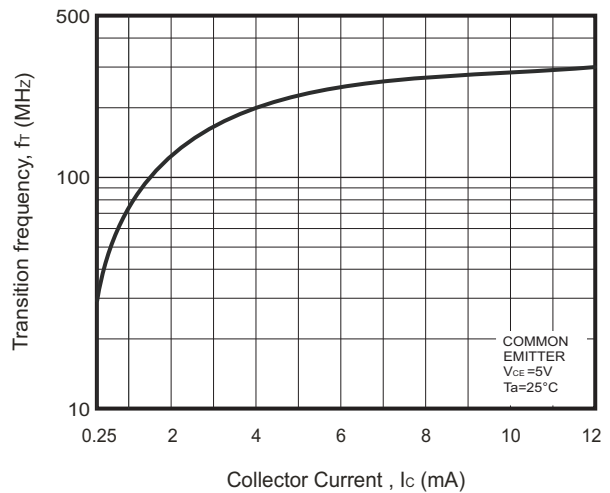
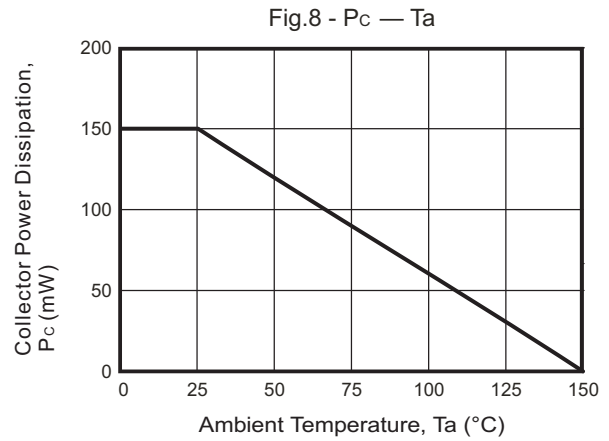
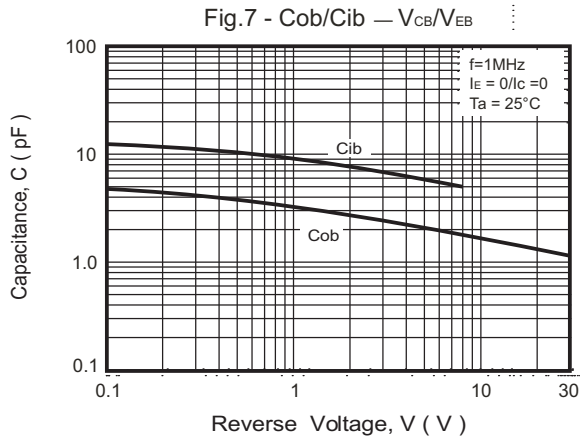

Fig.6 - $f_T - I_c$



Electrical Characteristic Curves (BC846W-G Thru. BC848W-G)



Reel Taping Specification

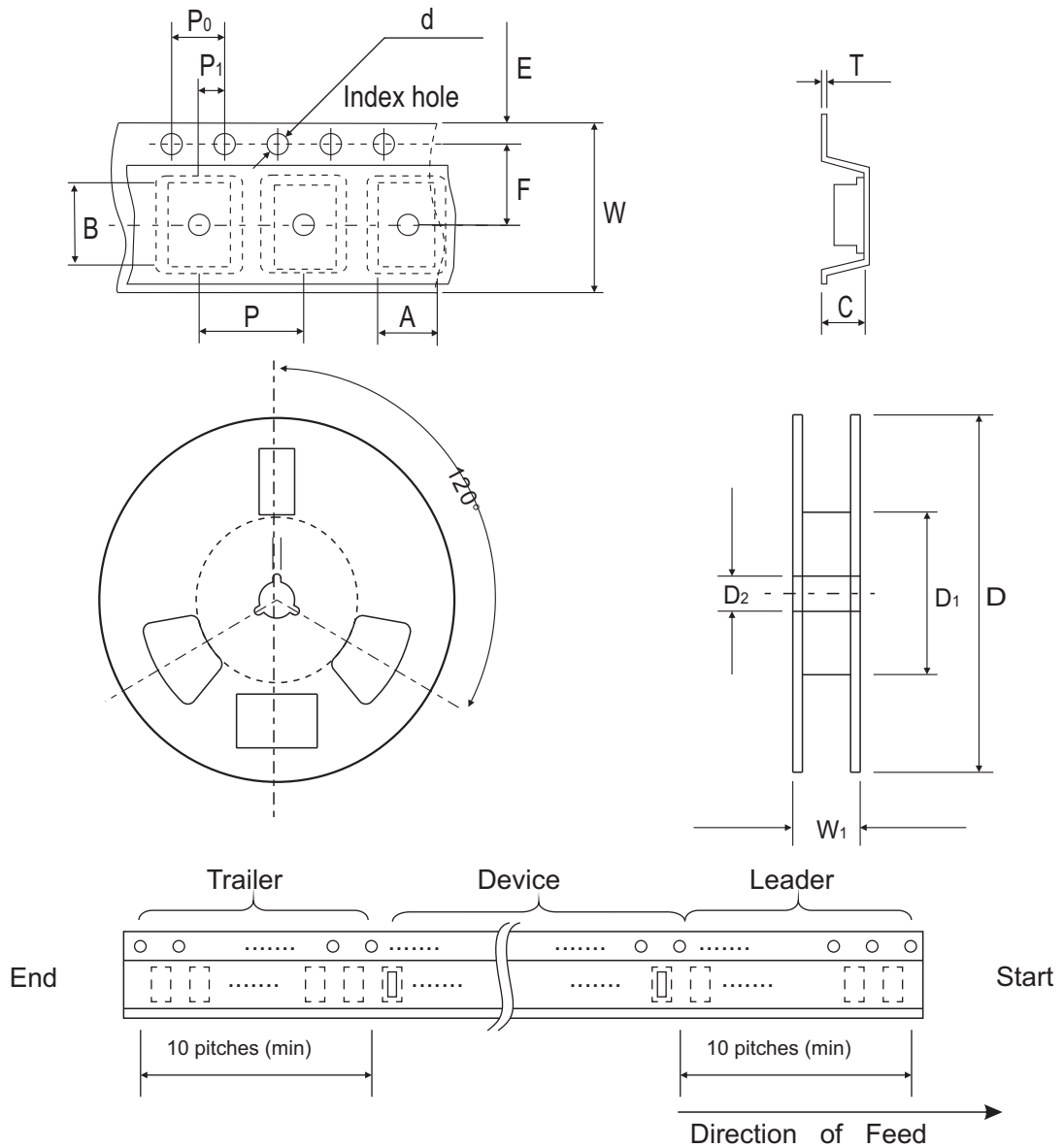

SOT-323	SYMBOL	A	B	C	d	D	D1	D2
	(mm)	2.25 ± 0.05	2.55 ± 0.05	1.19 ± 0.05	1.55 ± 0.10	178 ± 2.00	54.40 ± 1.00	13.00 ± 1.00
	(inch)	0.089 ± 0.002	0.100 ± 0.002	0.047 ± 0.002	0.061 ± 0.004	7.008 ± 0.079	2.142 ± 0.039	0.512 ± 0.039

SOT-323	SYMBOL	E	F	P	P0	P1	W	W1
	(mm)	1.75 ± 0.10	3.50 ± 0.10	4.00 ± 0.10	4.00 ± 0.10	2.00 ± 0.10	$8.00^{+0.30}_{-0.10}$	12.30 ± 1.00
	(inch)	0.069 ± 0.004	0.138 ± 0.002	0.158 ± 0.004	0.158 ± 0.004	0.079 ± 0.004	$0.315^{+0.012}_{-0.004}$	0.484 ± 0.039