

BC846A-G Thru. BC848C-G (NPN)

RoHS Device



Features

- Power dissipation
PCM: 0.20W (@TA=25°C)
- Collector current
ICM: 0.1A
- Collector-base voltage
VCBO: BC846=80V
BC847=50V
BC848=30V
- Operating and storage junction temperature range: TJ, TSTG= -65 to +150°C

Mechanical data

- Case: SOT-23, molded plastic.
- Terminals: solderable per MIL-STD-750, method 2026.
- Weight: 0.008 grams (approx.).

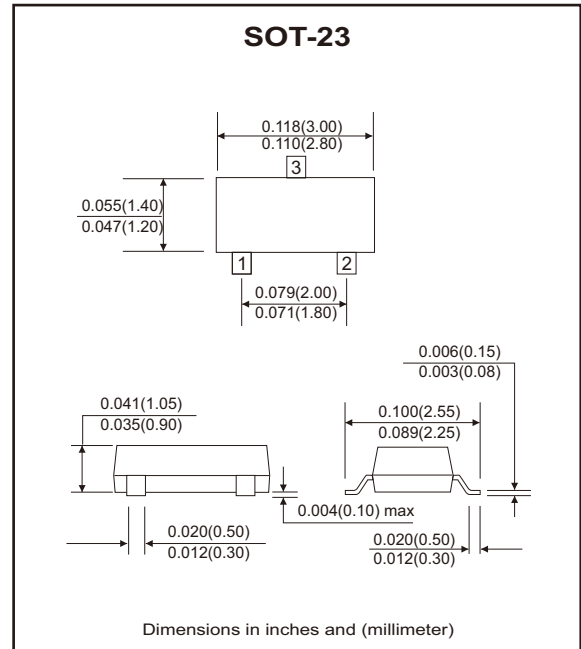

Circuit Diagram

- 1.BASE
- 2.EMITTER
- 3.COLLECTOR

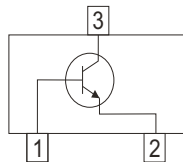

Maximum Ratings (at Ta=25°C unless otherwise noted)

Parameter	Symbol	Value	UNIT	
Collector-base voltage	BC846-G BC847-G BC848-G	VCBO	80 50 30	V
Collector-emitter voltage	BC846-G BC847-G BC848-G	VCEO	65 45 30	V
Emitter-base voltage		VEBO	6	V
Collector current-continuous		IC	0.1	A
Collector power dissipation		PC	200	mW
Junction temperature		TJ	150	°C
Storage temperature range		TSTG	-65 to +150	°C

Electrical Characteristics (BC846A-G Thru. BC848C-G, @TA= 25 °C unless otherwise specified)

Parameter	Symbol	Test Conditions	MIN	TYP	MAX	Unit
Collector-base breakdown voltage	BC846-G BC847-G BC848-G	V _{CBO}	I _C = 10μA, I _E = 0	80 50 30		V
Collector-emitter breakdown voltage	BC846-G BC847-G BC848-G	V _{CEO}	I _C = 10mA, I _B = 0	65 45 30		V
Emitter-base break voltage		V _{EBO}	I _E = 10μA, I _C = 0	6		V
Collector cut-off current	BC846-G BC847-G BC848-G	I _{CBO}	V _{CB} = 70V, I _E = 0 V _{CB} = 50V, I _E = 0 V _{CB} = 30V, I _E = 0		0.1	μA
Collector cut-off current	BC846-G BC847-G BC848-G	I _{CEO}	V _{CB} = 60V, I _E = 0 V _{CB} = 45V, I _E = 0 V _{CB} = 30V, I _E = 0		0.1	μA
Emitter cut-off current		I _{EBO}	V _{EB} = 5V, I _C = 0		0.1	μA
DC current gain	BC846A,BC847A,BC848A BC846B,BC847B,BC848B BC847C,BC848C	h _{FE}	V _{CE} = 5V, I _C = 2mA	110 200 420	220 450 800	
Collector-emitter saturation voltage		V _{CE(sat)}	I _C = 100mA, I _B = 5mA		0.5	V
Base-emitter saturation voltage		V _{BE(sat)}	I _C = 100mA, I _B = 5mA		1.1	V
Transition frequency		f _T	V _{CE} = 5V, I _C = 10mA f = 100MHz	100		MHz
Collector output capacitance		C _{ob}	V _{CB} = 10V, f = 1MHz		4.5	pF

Electrical Characteristic Curves (BC846A-G Thru. BC848C-G)

Fig.1 - Static Characteristic

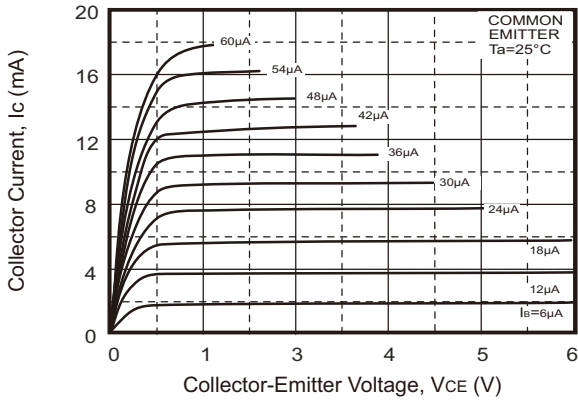

Fig.2 - hFE — Ic

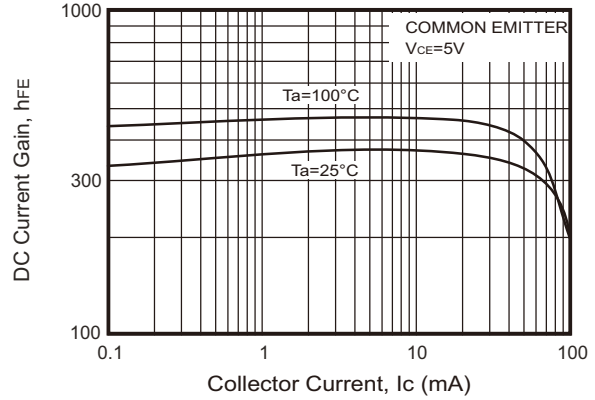

Fig.3 - VCEsat — Ic

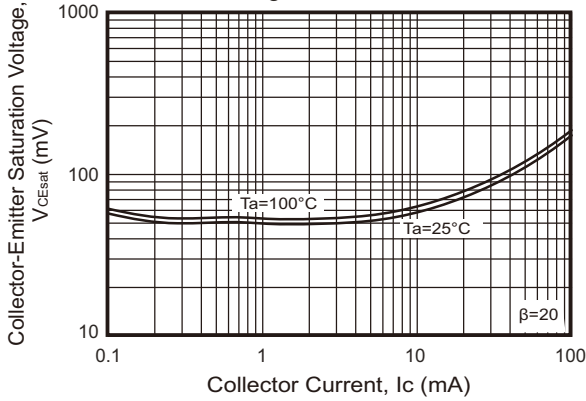

Fig.4 - VBEsat — Ic

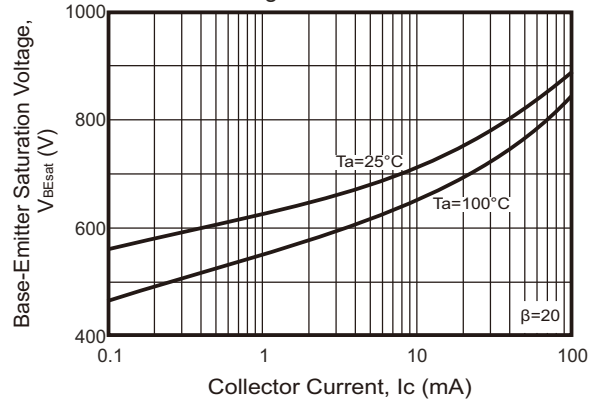

Fig.5 - Ic — VBE

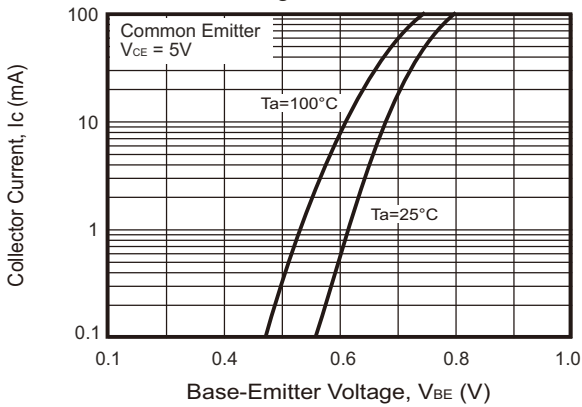

Fig.6 - Cob/Cib — VCB/VEB

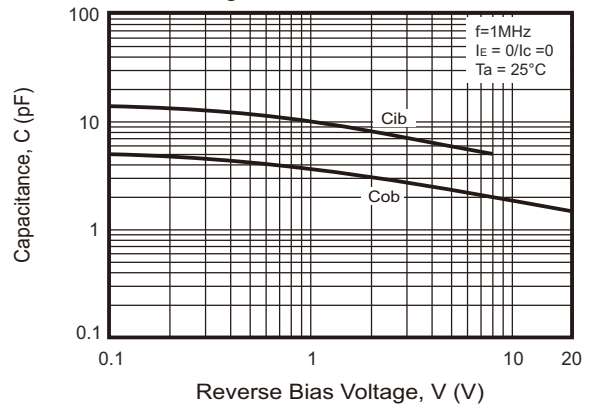

Fig.7 - fr — Ic

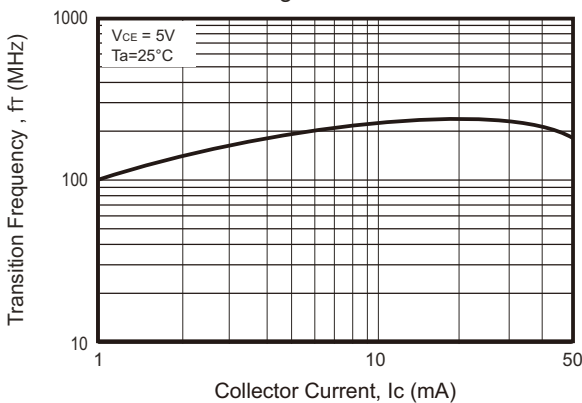
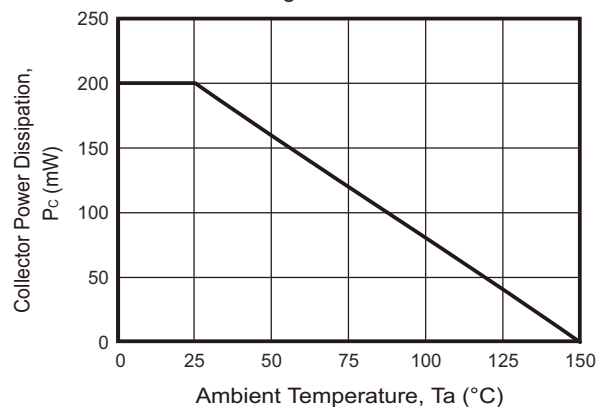
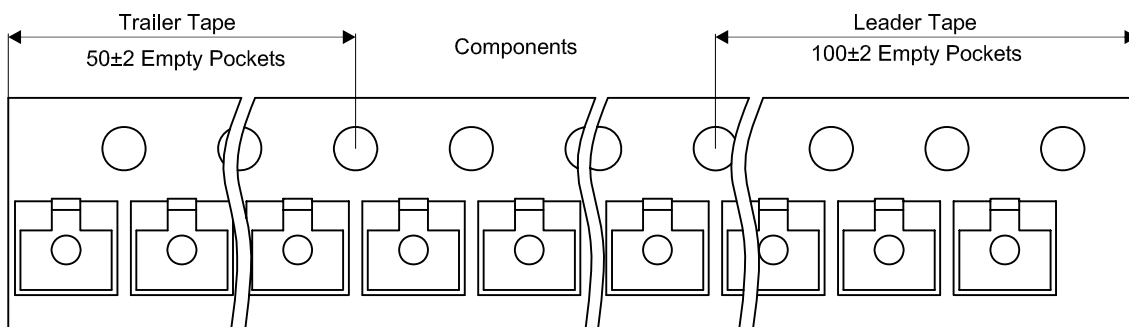
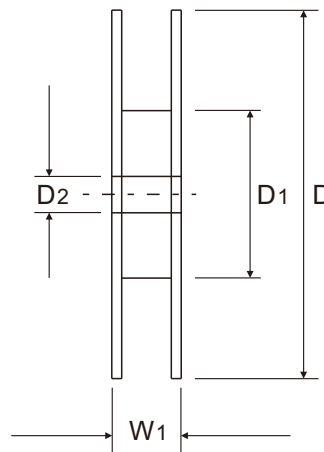
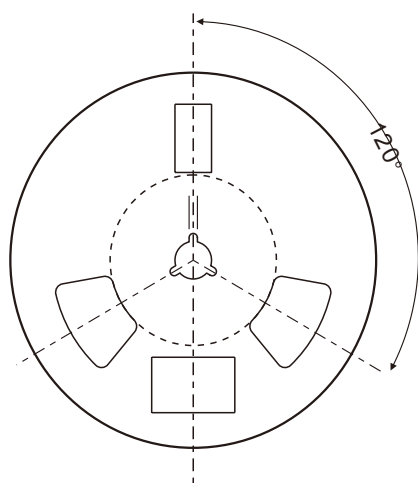
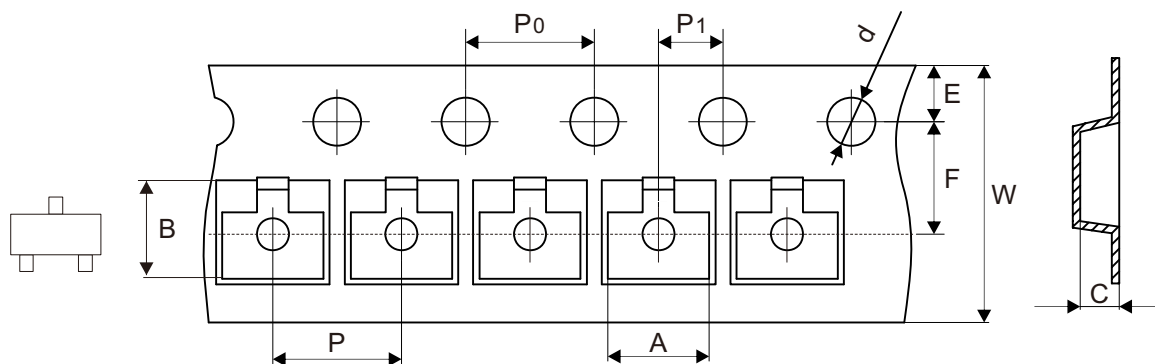

Fig.8 - Pc — Ta



Reel Taping Specification



SOT-23	SYMBOL	A	B	C	d	D	D1	D2
	(mm)	3.15 ± 0.10	2.77 ± 0.10	1.22 ± 0.10	1.50 ± 0.10	178.00 ± 2.00	54.40 ± 1.00	13.00 ± 1.00
	(inch)	0.124 ± 0.004	0.109 ± 0.004	0.048 ± 0.004	0.059 ± 0.004	7.008 ± 0.079	2.142 ± 0.039	0.512 ± 0.039

SOT-23	SYMBOL	E	F	P	P0	P1	W	W1
	(mm)	1.75 ± 0.10	3.50 ± 0.10	4.00 ± 0.10	4.00 ± 0.10	2.00 ± 0.10	8.00 + 0.30 - 0.10	12.30 ± 1.00
	(inch)	0.069 ± 0.004	0.138 ± 0.004	0.157 ± 0.004	0.157 ± 0.004	0.079 ± 0.004	0.315 + 0.012 - 0.004	0.484 ± 0.039