

Features

- Epitaxial Die Construction
- Complementary NPN Type Available BC847BV
- Ultra-Small Surface Mount Package
- Halogen Free. "Green" Device (Note 1)
- Moisture Sensitivity Level 1
- Epoxy Meets UL 94 V-0 Flammability Rating
- Lead Free Finish/RoHS Compliant ("P" Suffix Designates RoHS Compliant. See Ordering Information)

Maximum Ratings @ 25°C Unless Otherwise Specified

- Operating Junction Temperature Range: -55°C to +150°C
- Storage Temperature Range: -55°C to +150°C
- Thermal Resistance: 833°C/W Junction to Ambient

Parameter	Symbol	Rating	Unit
Collector-Base Voltage	V_{CBO}	-50	V
Collector-Emitter Voltage	V_{CEO}	-45	V
Emitter-Base Voltage	V_{EBO}	-5	V
Collector Current	I_C	-100	mA
Collector Power Dissipation	P_C	150	mW

Note: 1. Halogen free "Green" products are defined as those which contain <900ppm bromine, <900ppm chlorine (<1500ppm total Br + Cl) and <1000ppm antimony compounds.

Internal Structure

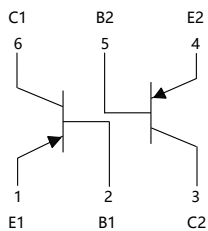

Marking: K5V

PNP Plastic Encapsulate Transistors

SOT-563

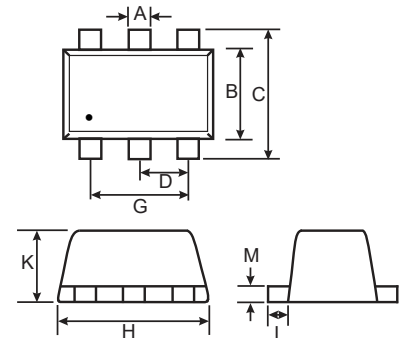

DIM	DIMENSIONS				NOTE
	INCHES		MM		
	MIN	MAX	MIN	MAX	
A	0.006	0.011	0.15	0.30	
B	0.043	0.051	1.10	1.30	
C	0.059	0.067	1.50	1.70	
D	0.020		0.50		TYP.
G	0.035	0.043	0.90	1.10	
H	0.059	0.067	1.50	1.70	
K	0.022	0.026	0.55	0.65	
L	0.004	0.011	0.10	0.30	
M	0.004	0.007	0.10	0.18	

Electrical Characteristics @ 25°C Unless Otherwise Specified

Parameter	Symbol	Min	Typ	Max	Units	Conditions
Collector-Base Breakdown Voltage	$V_{(BR)CBO}$	-50			V	$I_C = -10\mu A, I_E = 0$
Collector-Emitter Breakdown Voltage	$V_{(BR)CEO}$	-45			V	$I_C = -10mA, I_B = 0$
Emitter-Base Breakdown Voltage	$V_{(BR)EBO}$	-5			V	$I_E = -1\mu A, I_C = 0$
Collector-Base Cutoff Current	I_{CBO}			-15	nA	$V_{CB} = -30V, I_E = 0$
Emitter-Base Cutoff Current	I_{EBO}			-100	nA	$V_{EB} = -5V, I_C = 0$
DC Current Gain	h_{FE}	220		475		$V_{CE} = -5V, I_C = -2mA$
Collector-Emitter Saturation Voltage	$V_{CE(sat)}$			-0.1	V	$I_C = -10mA, I_B = -0.5mA$
				-0.4	V	$I_C = -100mA, I_B = -5mA$
Base-Emitter Saturation Voltage	$V_{BE(sat)}$		-0.7		V	$I_C = -10mA, I_B = -0.5mA$
			-0.9		V	$I_C = -100mA, I_B = -5mA$
Base-Emitter Voltage	V_{BE}	-0.6		-0.75	V	$V_{CE} = -5V, I_C = -2mA$
				-0.82	V	$V_{CE} = -5V, I_C = -10mA$
Collector Output Capacitance	C_{ob}			4.5	pF	$V_{CB} = -10V, I_E = 0, f = 1MHz$
Transition Frequency	f_T	100			MHz	$V_{CE} = -5V, I_C = -10mA, f = 100MHz$
Noise Figure	NF			10	dB	$V_{CE} = -5V, I_C = -0.2mA, f = 1KHz$ $R_S = 2K\Omega, \Delta f = 200Hz$

Curve Characteristics

Fig. 1 - Static Characteristics

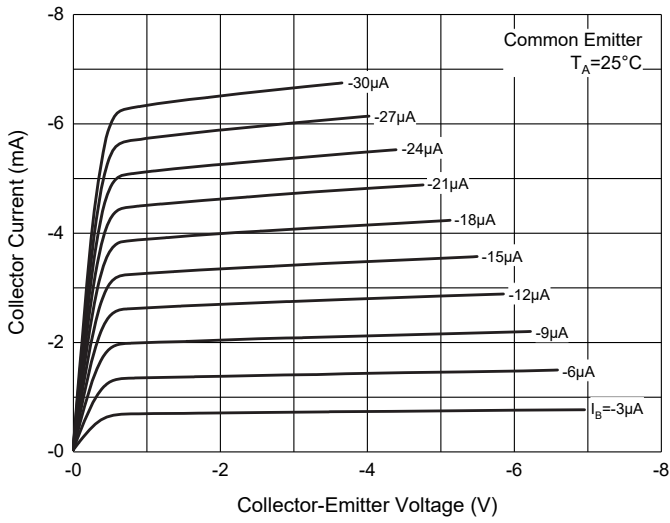

Fig. 2 - DC Current Gain Characteristics

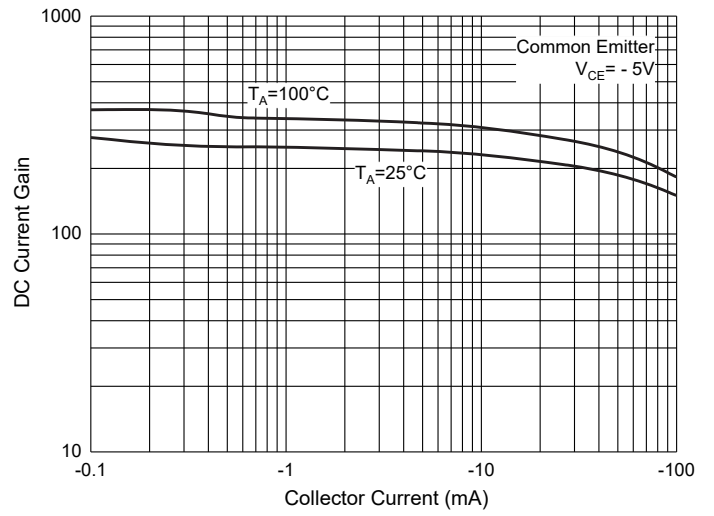

Fig. 3 - Collector-Emitter Saturation Voltage Characteristics

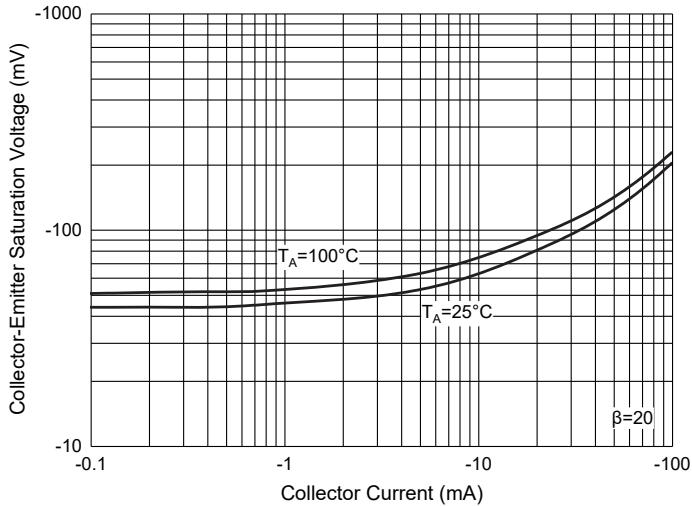

Fig. 4 - Base-Emitter Saturation Voltage Characteristics

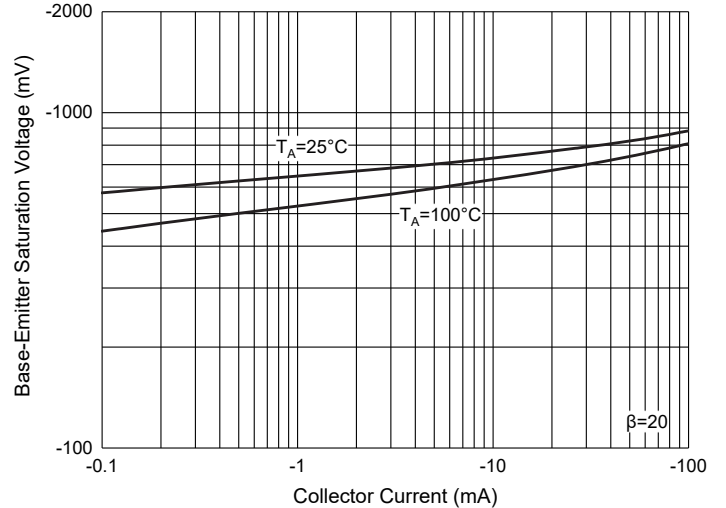

Fig. 5 - Base-Emitter Voltage Characteristics

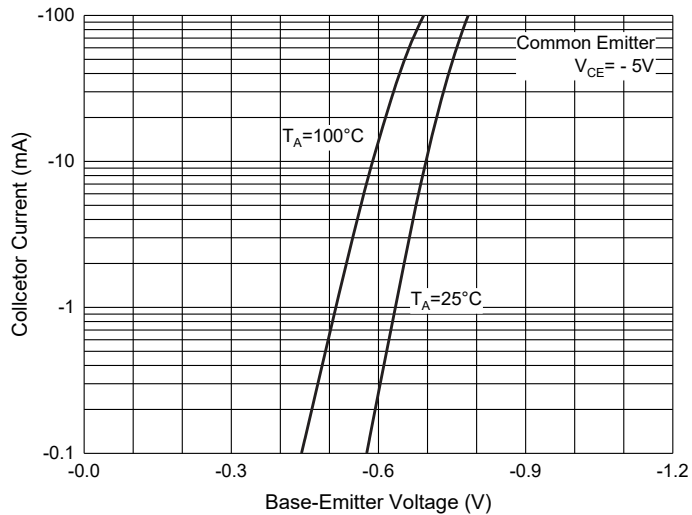

Fig. 6 - Collector Power Derating Curve

