



Micro Commercial Components
 20736 Marilla Street Chatsworth
 CA 91311
 Phone: (818) 701-4933
 Fax: (818) 701-4939

Micro Commercial Components

Features

- Lead Free Finish/RoHS Compliant ("P" Suffix designates RoHS Compliant. See ordering information)
- Ideally Suited for Automatic Insertion
- 150°C Junction Temperature
- Low Current, Low Voltage
- For Switching and AF Amplifier applications.
- Suited for low level, low noise, low frequency Applications in hybrid circuits
- Epoxy meets UL 94 V-0 flammability rating
- Moisture Sensitivity Level 1
- Halogen free available upon request by adding suffix "-HF"

Maximum Ratings

- Terminals: Solderable per MIL-STD-202, Method 208
- Weight: 0.008 grams (approx.)
- Marking :

MCC P/N	Marking	MCC P/N	Marking
BCX70G	AG	BCX70J	AJ
BCX70H	AH	BCX70K	AK

Maximum Ratings @ 25°C Unless Otherwise Specified

Charateristic	Symbol	Value	Unit
Collector-Emitter Voltage	V_{CEO}	45	V
Collector-Base Voltage	V_{CBO}	45	V
Emitter-Base Voltage	V_{EBO}	5	V
Collector Current(DC)	I_C	200	mA
Base Current(DC)	I_B	50	mA
Power Dissipation@ $T_s=79^\circ\text{C}$	P_d	250	mW
Thermal Resistance, Junction to Ambient Air	$R_{\theta JA}$	500 ⁽¹⁾	$^\circ\text{C/W}$
Operating & Storage Temperature	T_j, T_{STG}	-55~150	$^\circ\text{C}$

Notes:

- (1) Mounted on FR-4 printed-circuit board

BCX70G THRU BCX70K

NPN Small Signal Transistor 250mW

SOT-23

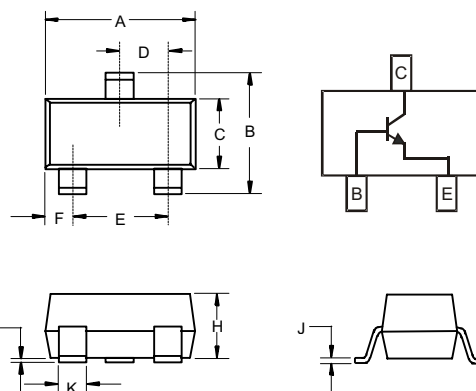

DIM	INCHES		MM		NOTE
	MIN	MAX	MIN	MAX	
A	.110	.120	2.80	3.04	
B	.083	.104	2.10	2.64	
C	.047	.055	1.20	1.40	
D	.035	.041	.89	1.03	
E	.070	.081	1.78	2.05	
F	.018	.024	.45	.60	
G	.0005	.0039	.013	.100	
H	.035	.044	.89	1.12	
J	.003	.007	.085	.180	
K	.015	.020	.37	.51	

Suggested Solder Pad Layout

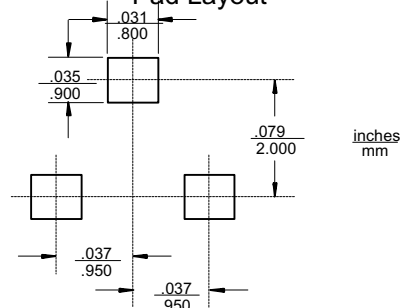

BCX70 Series



Micro Commercial Components

Electrical Characteristics (T_J = 25°C unless otherwise noted)

Parameter	Symbol	Test Condition	Min	Typ	Max	Unit
DC Current Gain	BCX70G	V _{CE} = 5 V, I _C = 10 μA	—	—	—	
	BCX70H	V _{CE} = 5 V, I _C = 10 μA	30	—	—	
	BCX70J	V _{CE} = 5 V, I _C = 10 μA	40	—	—	
	BCX70K	V _{CE} = 5 V, I _C = 10 μA	100	—	—	
	BCX70G	V _{CE} = 5 V, I _C = 2 mA	120	—	220	
	BCX70H	V _{CE} = 5 V, I _C = 2 mA	180	—	310	
	BCX70J	V _{CE} = 5 V, I _C = 2 mA	250	—	460	
	BCX70K	V _{CE} = 5 V, I _C = 2 mA	380	—	630	
	BCX70G	V _{CE} = 1 V, I _C = 50 mA	50	—	—	
	BCX70H	V _{CE} = 1 V, I _C = 50 mA	70	—	—	
	BCX70J	V _{CE} = 1 V, I _C = 50 mA	90	—	—	
	BCX70K	V _{CE} = 1 V, I _C = 50 mA	100	—	—	
	Collector-Emitter Saturation Voltage	V _{CEsat}	I _C = 10 mA, I _B = 0.25 mA I _C = 50 mA, I _B = 1.25 mA	50 100	— —	350 550
Base-Emitter Saturation Voltage	V _{BEsat}	I _C = 10 mA, I _B = 0.25 mA I _C = 50 mA, I _B = 1.25 mA	600 700	— —	850 1050	mV
Base-Emitter Voltage	V _{BE}	V _{CE} = 5 V, I _C = 2 mA V _{CE} = 5 V, I _C = 10 μA V _{CE} = 1 V, I _C = 50 mA	550 — —	650 520 780	750 — —	mV
Collector Cut-off Current	I _{CBO}	V _{CB} = 45 V, V _{BE} = 0 V V _{CB} = 45 V, V _{BE} = 0 V T _A = 150°C	— —	— —	20 20	nA μA
Emitter Cut-off Current	I _{EBO}	V _{EB} = 4 V, I _C = 0	—	—	20	nA
Gain-Bandwidth Product	f _T	V _{CE} = 5 V, I _C = 10 mA f = 100 MHz	100	250	—	MHz
Collector-Base Capacitance	C _{CB0}	V _{CB} = 10 V, f = 1 MHz, I _E = 0	—	2.5	—	pF
Emitter-Base Capacitance	C _{EB0}	V _{EB} = 0.5 V, f = 1 MHz, I _C = 0	—	8	—	pF
Noise Figure	F	V _{CE} = 5 V, I _C = 200 μA, R _S = 2 kΩ, f = 1 kHz, B = 200 Hz	—	2	6	dB
Small Signal Current Gain	BCX70G	V _{CE} = 5 V, I _C = 2 mA, f = 1.0 kHz	—	200		
	BCX70H		—	260		
	BCX70J		—	330		
	BCX70K		—	520		
Turn-on Time at R _L = 990Ω (see fig. 1)	t _{on}	V _{CC} = 10 V, I _C = 10 mA, I _{B(on)} = -I _{B(off)} = 1 mA	—	85	150	ns
Turn-off Time at R _L = 990Ω (see fig. 1)	t _{off}	V _{CC} = 10 V, I _C = 10 mA, I _{B(on)} = -I _{B(off)} = 1 mA	—	480	800	ns