

Low ON resistance USB high-side switch series

BD6510F / BD6512F / BD6513F

This series of high-side switching ICs have 2-channel MOSFET switches that have low ON resistances. These functions are useful for USB power control. Error signals can be conveyed via a built-in error detection circuit. Also included is a thermal shutdown circuit with a latch that can protect the output from unstable operation occurred by repeating the ON/OFF switch of the output protection circuit.

●Applications

USB hub, Notebook PC, Desk-top PC, Power switch

●Features

- 1) Dual D-MOS High-side switches.
- 2) Control logic Active-High (BD6510F / BD6512F)
Active-Low (BD6513F)
High level input > 2.5V , Low level input < 0.7V
- 3) Low on resistance Typ. = 100mΩ (VDD = 5V)
- 4) Continuous output load current Min. = 1A (BD6510F)
Min. = 0.6A (BD6512F / BD6513F)
- 5) Soft start circuit
- 6) Error detection circuit, Output protection circuit (Over current detector, Thermal shutdown, Under voltage lockout.)
- 7) Open-drain Error Flag output.

●Absolute maximum ratings (Ta=25°C)

Parameter	Symbol	Limits	Unit
Supply voltage	V _{DD}	-0.3 to +6.0	V
Terminal Input	V _{IN}	-0.3 to V _{DD} +0.3	V
Storage Temperature	T _{STG}	-55 to +125	°C
Power dissipation *	P _d	450	mW

*This value decreases 4.5mW/°C above 25°C.
Resistance radiation design is not doing.

●Recommended operating conditions (Ta=25°C)

Parameter	Symbol	Limits	Unit
Supply voltage	V _{DD}	+3.0 to +5.5	V
Operating temperature	T _{OPR}	-25 to +85	°C

Multimedia ICs

●Block diagram

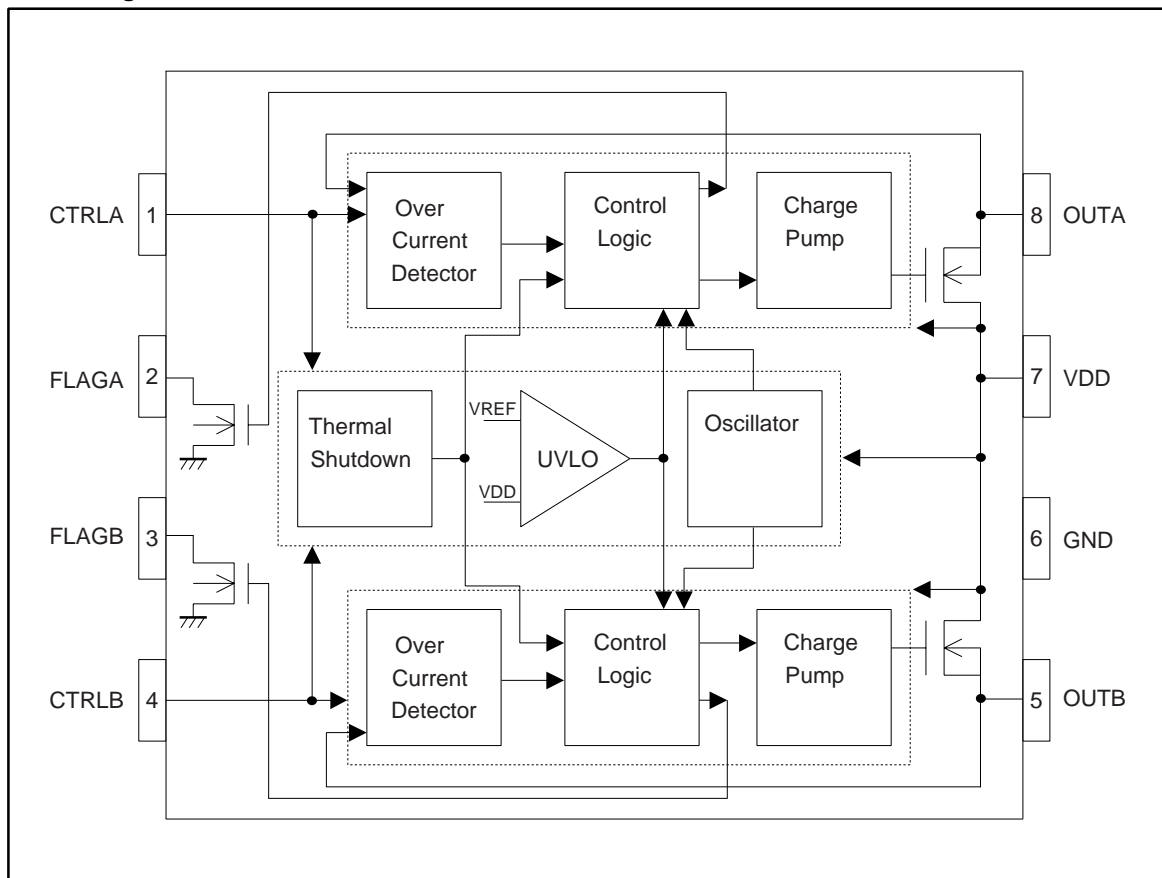

●Pin description

Pin No.	Pin name	I / O	Pin description
1 4	CTRLA CTRLB	IN	Control input : High input >2.5V, Low input <0.7V
2 3	FLAGA FLAGB	OUT	Error flag output : Active-low, open-drain output.
5 8	OUTB OUTA	OUT	Switch output (Output D-MOS SW source)
6	V _{SS}	-	Ground
7	V _{DD}	-	Power supply (Output D-MOS SW drain)

Multimedia ICs

●Internal circuit

Pin No.	Pin name	Equivalent circuit
1 4	CTRL A CTRL B	
2 3	FLAG A FLAG B	
8 5	OUT A OUT B	

Multimedia ICs

●Electrical characteristics (Unless otherwise noted, VDD = 5V, Ta=25°C)

Parameter	Symbol	Min.	Typ.	Max.	Unit	Conditions
Operating current	IDD	-	85	120	μA	OUT=OPEN, VCTRL=5V(BD6510F/12F) VCTRL=0V(BD6513F)
		-	0.01	2	μA	OUT=OPEN, VCTRL=0V(BD6510F/12F) VCTRL=5V(BD6513F)
Control input voltage	VCTRL	-	-	0.7	V	CTRL Low Level Input
		2.5	-	-	V	CTRL High Level Input
Control input current	ICTRL	-1	0.01	1	μA	VCTRL=0V or 5V
On resistance	RON	-	100	130	mΩ	VDD=5V, IOU=500mA
		-	120	160	mΩ	VDD=3.3V, IOU=500mA
Turn on delay	TRD	100	600	2000	μs	RL=10Ω "VCTRL=L→H"→VOUT=50% (BD6510F/12F) "VCTRL=H→L"→VOUT=50% (BD6513F)
Turn on rise time	TR	200	1500	6000	μs	RL=10Ω VOUT=10%→90%
Turn off delay	TFD	-	3	20	μs	RL=10Ω "VCTRL=H→L"→VOUT=50% (BD6510F/12F) "VCTRL=L→H"→VOUT=50% (BD6513F)
Turn off fall time	TF	-	1	20	μs	RL=10Ω VOUT=90%→10%
UVLO threshold voltage	VUVLOH	2.3	2.5	2.7	V	VDD increasing
	VUVLOL	2.1	2.3	2.5	V	VDD decreasing
Thermal shutdown threshold	TTS	-	135	-	°C	
Over current limit threshold level	ITHLIM	1	2	3	A	(BD6510F)
		1.25	1.65	2.20	A	(BD6512F/13F)
Over current limit level	ILIM	0.6	1.1	1.6	A	(BD6512F/13F)
Flag output resistance	RFLAG	-	16	40	Ω	IFLAG=5mA (BD6510F) IFLAG=10mA (BD6512F/13F)
Flag off current	IFLAG	-	0.01	1	μA	

●Test circuit

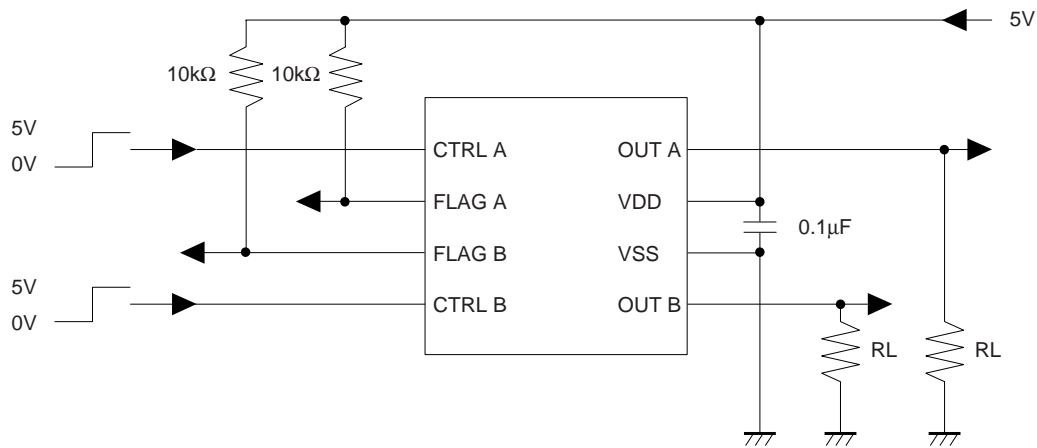

Multimedia ICs

●Functional description

	BD6510F	BD6512F	BD6513F
Control logic	Hi-Active	Hi-Active	Lo-Active
Over current detector threshold level	1A~2.0A(typ.)~3A	1.25A~1.65A(typ.)~2.20A	
Over current limit level	–	0.6A~1.1A(typ.)~1.6A	
Switch current	1A(Min.)	0.6A(Min.)	

Circuit name	Operating description	Error flag latch
Thermal shutdown (TSD)	Thermal shutdown shut off the both output MOSFET and signals error flag is the chip temperature exceeds T_{TS} . TSD function only when the CTRL is enable.	○ *
Under voltage lockout (UVLO)	UVLO prevents the output MOSFET from turning on until V_{DD} exceeds V_{UVLOH} and signals error flag. After the switch turn on, if V_{DD} drops below V_{UVLOL} shut off the output MOSFET and signals error flag. UVLO functions only when the CTRL is enable.	×
Over current detector (OCD)	Over current detector shut off the output MOSFET and signals error flag if output current exceeds I_{LIM} . OCD functions only when the CTRL is enable.	×

* Latch is released by forcing CTRL input SW OFF level or detecting UVLO.
 Connect a bypass capacitor from V_{DD} to GND, located near the IC. Recommend over 1 μ F.
 Connect a over 100k Ω pull-up resistor from FLAG to V_{DD} .

●Application circuit

