

Features

- Halogen Free. "Green" Device (Note 1)
- Moisture Sensitivity Level 1
- Epoxy Meets UL 94 V-0 Flammability Rating
- Lead Free Finish/RoHS Compliant ("P" Suffix Designates RoHS Compliant. See Ordering Information)

Maximum Ratings @ 25°C Unless Otherwise Specified

- Operating Junction Temperature Range: -55°C to +150°C
- Storage Temperature Range: -55°C to +150°C
- Thermal Resistance: 250°C/W Junction to Ambient

Parameter	Symbol	Rating	Unit
Collector-Base Voltage	V_{CBO}	-40	V
Collector-Emitter Voltage	V_{CEO}	-30	V
Emitter-Base Voltage	V_{EBO}	-5	V
Continuous Collector Current	I_C	-3	A
Peak Collector Current	I_{CM}	-7	A
Base Current	I_B	-0.6	A
Power Dissipation	P_D	0.5	W

Note: 1. Halogen free "Green" products are defined as those which contain <900ppm bromine, <900ppm chlorine (<1500ppm total Br + Cl) and <1000ppm antimony compounds.

Marking: B772

Internal Structure

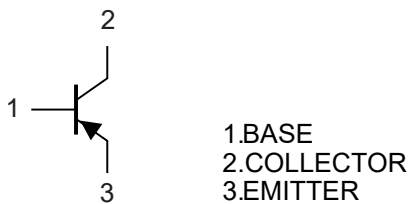

**PNP Silicon
Plastic-Encapsulate
Transistor**

SOT-89

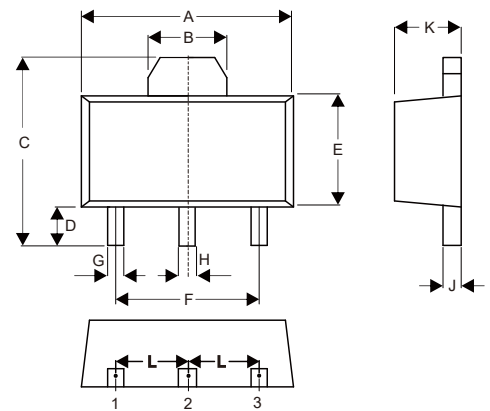

DIM	INCHES		MM		NOTE
	MIN	MAX	MIN	MAX	
A	0.169	0.185	4.30	4.70	
B	0.061		1.55		TYP.
C	0.154	0.171	3.91	4.35	
D	0.031	0.047	0.80	1.20	
E	0.089	0.104	2.25	2.65	
F	0.118		3.00		TYP.
G	0.013	0.020	0.33	0.52	
H	0.015	0.021	0.38	0.53	
J	0.014	0.017	0.35	0.44	
K	0.055	0.063	1.40	1.60	
L	0.059		1.50		TYP.

Suggested Solder Pad Layout

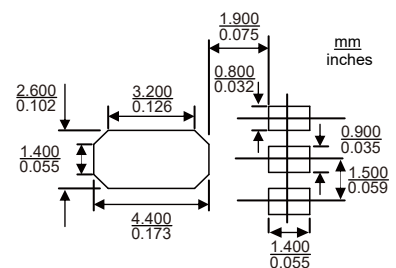

Electrical Characteristics @ $T_A=25^\circ\text{C}$ Unless Otherwise Specified

Parameter	Symbol	Min	Typ	Max	Units	Conditions
Collector-Base Breakdown Voltage	$V_{(BR)CBO}$	-40			V	$I_C=-100\mu\text{A}, I_E=0$
Collector-Emitter Breakdown Voltage	$V_{(BR)CEO}$	-30			V	$I_C=-10\text{mA}, I_B=0$
Emitter-Base Breakdown Voltage	$V_{(BR)EBO}$	-6			V	$I_E=-100\mu\text{A}, I_C=0$
Collector Cutoff Current	I_{CBO}			-1	μA	$V_{CB}=-40\text{V}, I_E=0$
Collector Cutoff Current	I_{CEO}			-10	μA	$V_{CE}=-30\text{V}, I_B=0$
Emitter Cutoff Current	I_{EBO}			-1	μA	$V_{EB}=-6\text{V}, I_C=0$
DC Current Gain	h_{FE}	60		400		$V_{CE}=-2\text{V}, I_C=-1\text{A}$
Collector-Emitter Saturation Voltage	$V_{CE(sat)}$			-0.5	V	$I_C=-2\text{A}, I_B=-0.2\text{A}$
Base-Emitter Saturation Voltage	$V_{BE(sat)}$			-1.5	V	$I_C=-2\text{A}, I_B=-0.2\text{A}$
Transition Frequency	f_T	80			MHz	$V_{CE}=-5\text{V}, I_C=-0.1\text{A}, f=10\text{MHz}$

Classification of h_{FE}

Rank	R	O	Y	GR
Range	60-120	100-200	160-320	200-400

Curve Characteristics

Fig. 1 - Static Characteristics

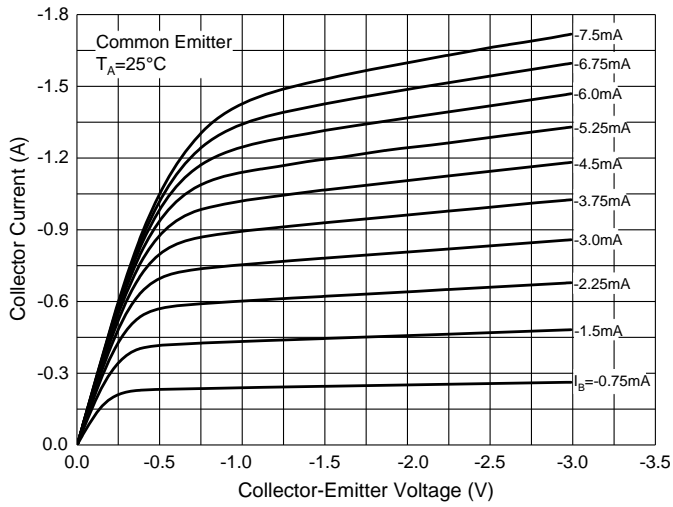

Fig. 2 - DC Current Gain Characteristics

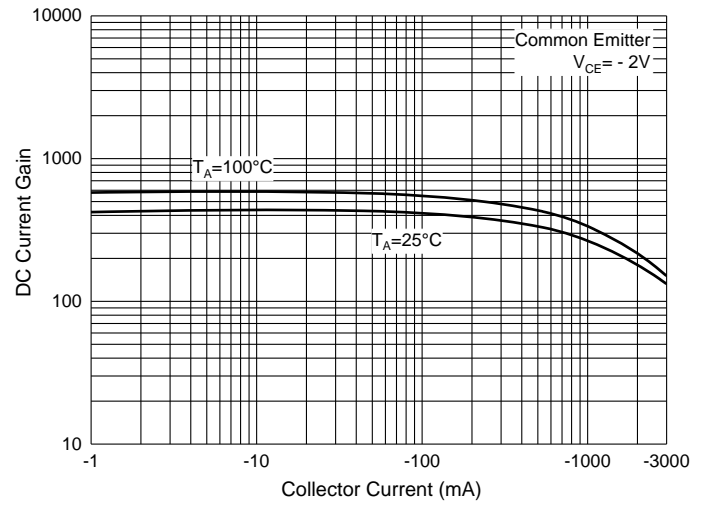

Fig. 3 - Base-Emitter Saturation Voltage Characteristics

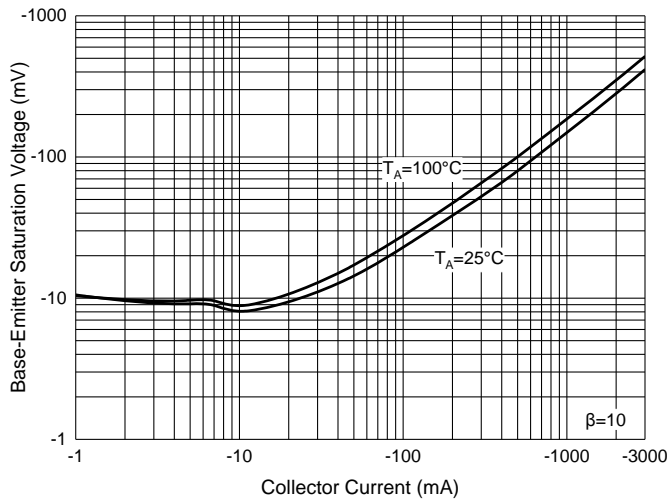

Fig. 4 - Base-Emitter Saturation Voltage Characteristics

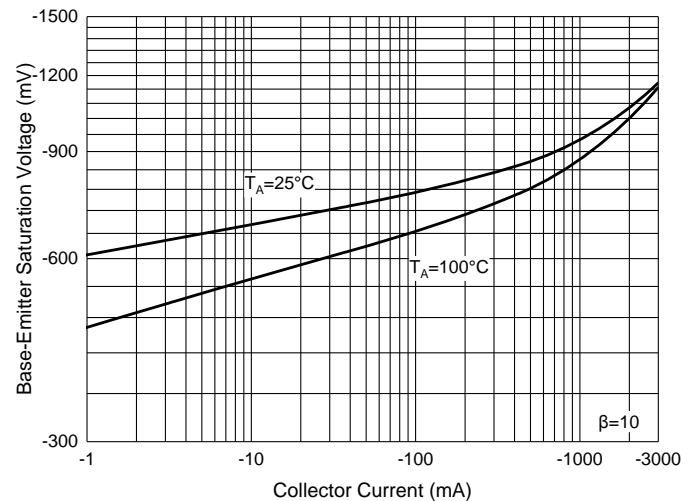

Fig. 5 - Base-Emitter Voltage Characteristics

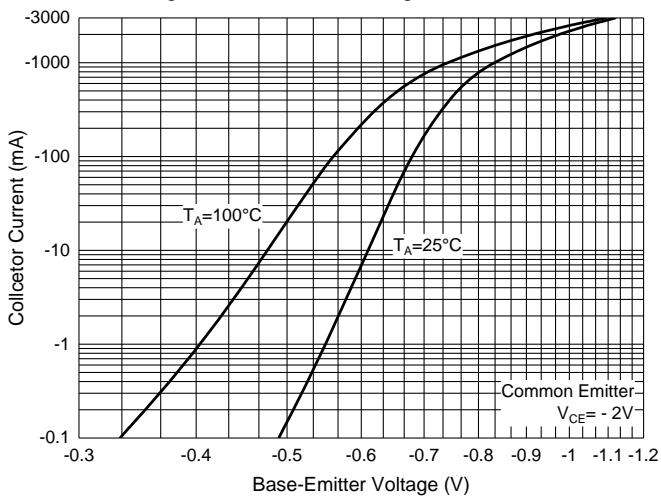

Fig. 6 - Collector Power Derating Curve

