

DASH #	MODEL #
-1	BJ157HS
-2	BJ157FLHS

ZONE	REV	ECO	DESCRIPTION	APPROVER	DATE
	C	53428		T. KOHLER	6/27/11
	D	54001		T. KOHLER	2/8/12

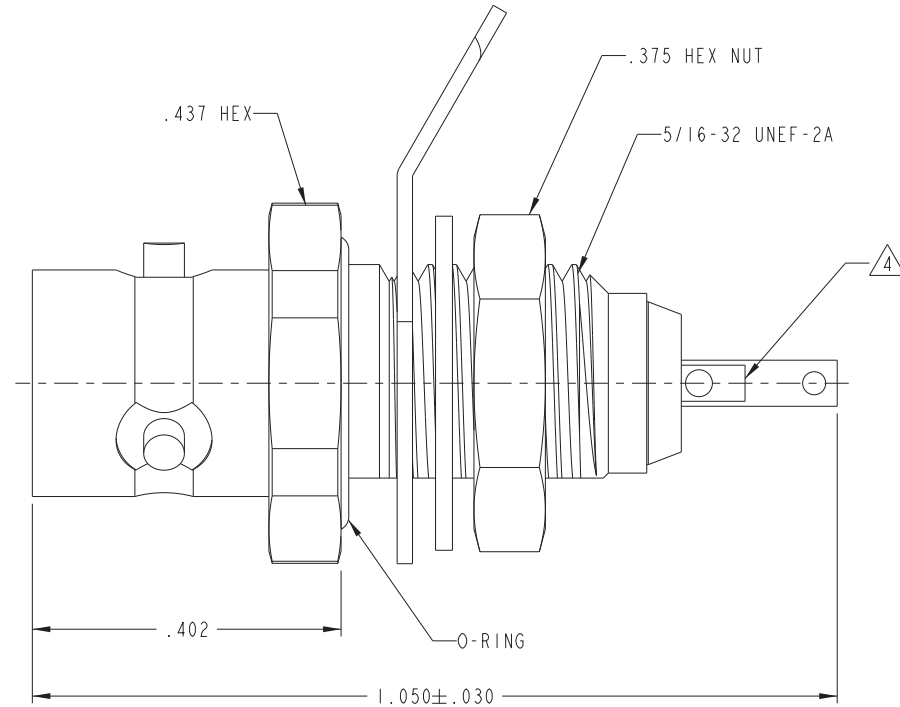

- 1 SHOWN

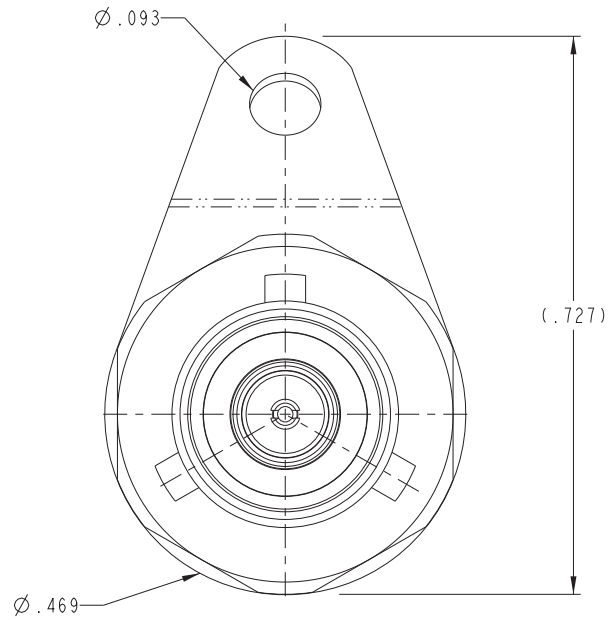
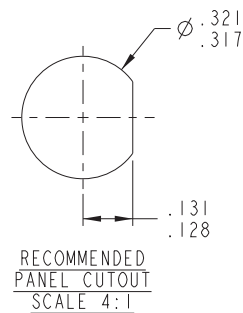

6. HERMETICITY:  $1 \times 10^{-8}$  CC/SEC MAX LEAKAGE RATE
5. SUBMINIATURE TRIAXIAL SOLDER POT BULKHEAD RECEPTACLE (TRS STYLE), HERMETICALLY SEALED, STANDARD 3-LUG & 4-LUG BAYONET SLEEVE.

△ SOLDER POT ACCEPTS  $\phi .034$  MAX CONDUCTOR

3. MAX PANEL THK: .187

2. FINISH: GOLD

△ MATERIAL; STAINLESS STEEL

	MODEL NO.	CAGE CODE 14949			
	<small>THIS PROPRIETARY DOCUMENT IS PROPERTY OF EMERSON NETWORK POWER CONNECTIVITY SOLUTIONS. IT IS CONFIDENTIAL IN NATURE. NON-TRANSFERABLE, AND ISSUED WITH A CLEAR UNDERSTANDING THAT IT IS NOT FACED OR COPIED WITHOUT PERMISSION AND IS RETURNABLE UPON DEMAND.</small>	<small>UNLESS OTHERWISE SPECIFIED UNITS: INCH .XX ± .005 .XXX ± .005 .XXXX ± .005 ANGLE ± CRITICAL</small>	<small>3RD ANGLE PROJECTION</small> 	<small>TITLE</small> BJ157HS/FLHS	<small>MATERIAL</small> 
<small>APPROVED BY</small> T. KOHLER	<small>DATE</small> 2/9/12	<small>DRAWING NO.</small> 305-0828	<small>REV.</small> D	<small>FINISH</small> 	<small>DATE</small> 2/9/12
<small>SIZE</small> C		<small>DO NOT SCALE DRAWING</small>	<small>SCALE 8:1</small>	<small>SHEET 1 OF 2</small>	