

DATA CONTAINED IN THIS DOCUMENT IS PROPRIETARY TO EMERSON CONNECTIVITY SOLUTIONS AND SHALL NOT BE DISCLOSED, COPIED OR USED FOR PROMOTION OR MANUFACTURE WITHOUT EXPRESS WRITTEN PERMISSION

REVISIONS			
REV	DESCRIPTIONS	DATE	APPROVED
J	ECO 54989	4/30/14	P. KLYVE

KEYING LETTER	A°	B°	C°
NONE	120	120	120
S	135	135	90
T	100	150	110
U	120	130	110
V	115	130	115
W	125	110	125
X	130	100	130
Y	110	140	110
Z	100	160	100

MODEL NUMBER	INCLUDED ITEMS
BJ770	CONNECTOR HEX NUT LOCK WASHER
BJ770GL	CONNECTOR HEX NUT LOCK WASHER GROUND LUG

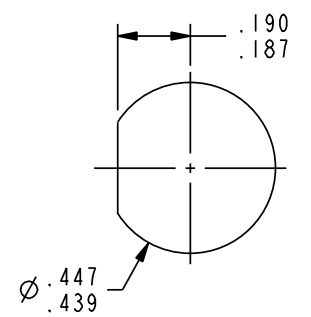

RECOMMENDED PANEL CUTOUT

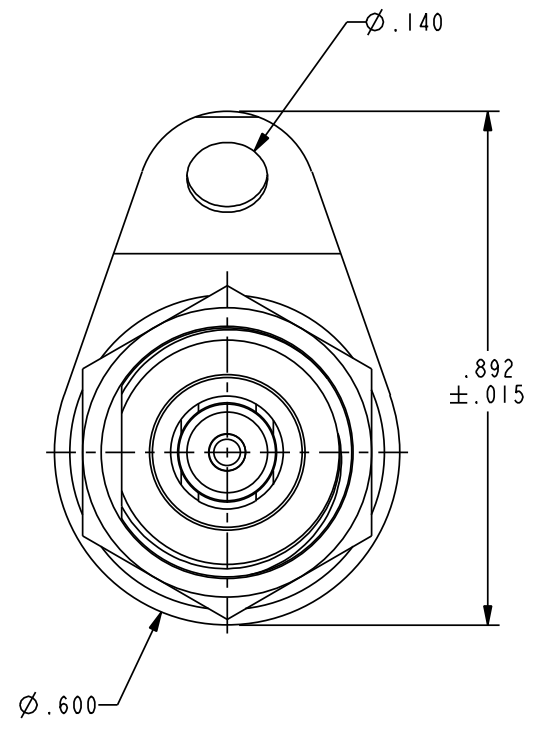
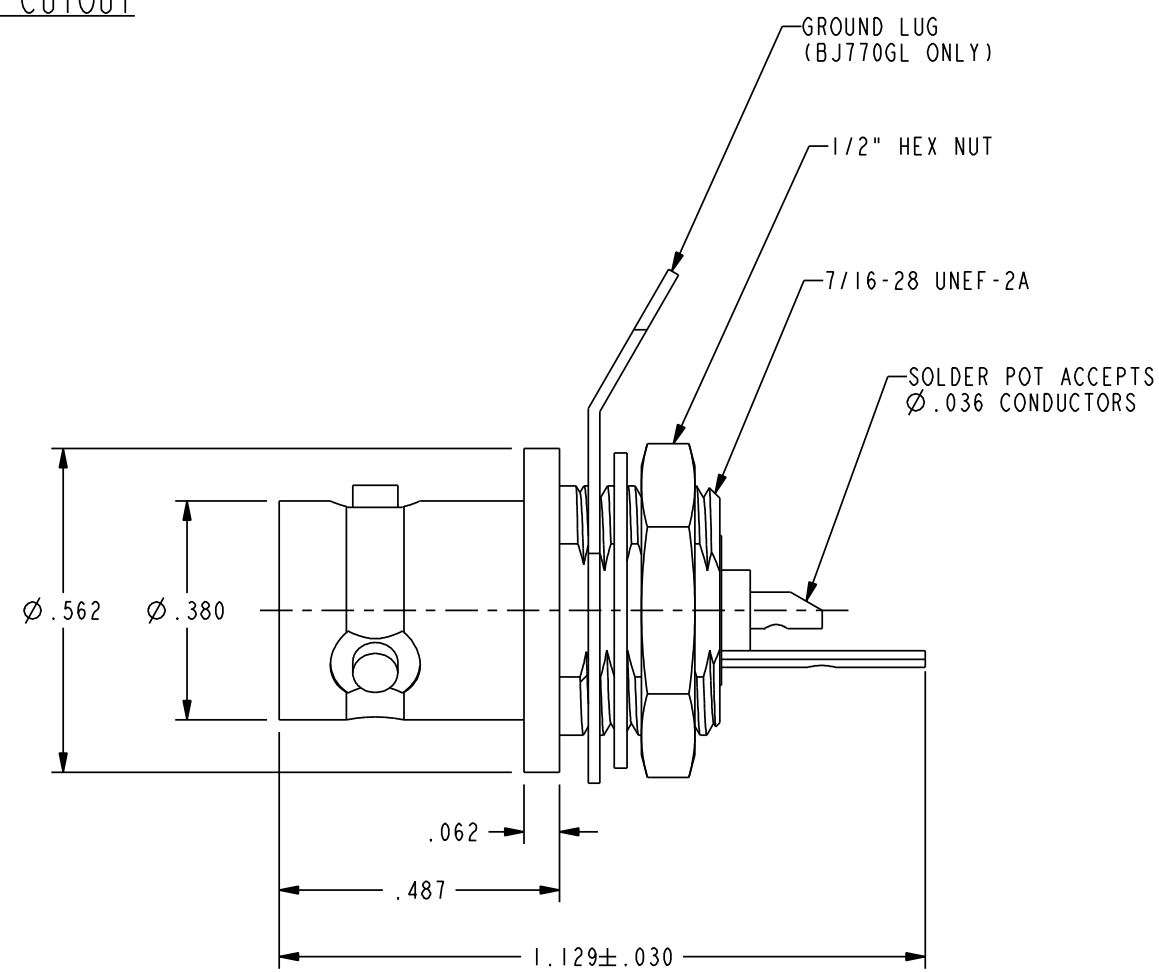
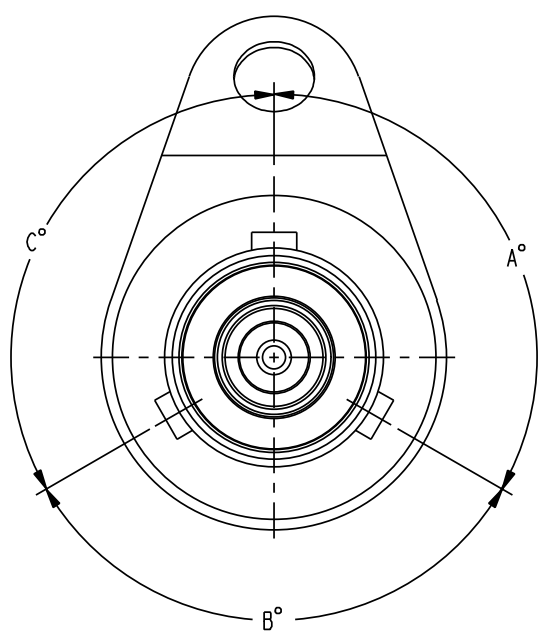
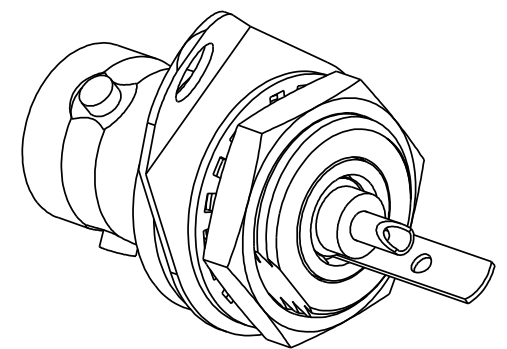

4. EXAMPLE OF COMPLETE MODEL NUMBER:

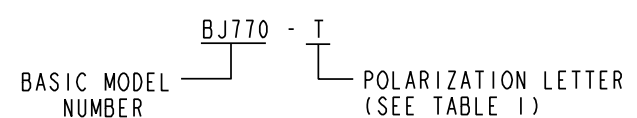

3. MAXIMUM PANEL THICKNESS .125

2. SOCKET CONTACT CONCENTRIC TWINAX/  
TRIAx TRB SOLDER POT BULKHEAD  
MOUNT RECEPTACLE

1. FINISH: NICKEL

NOTES: UNLESS OTHERWISE SPECIFIED.

INTERPRET DRAWING PER MIL-STD-100. DIMENSIONS ARE IN INCHES AND INCLUDE FINISH THICKNESS UNLESS OTHERWISE SPECIFIED.		TOL: UNLESS SPECIFIED. .XX ± .01 .XXX ± .003 .XXXX ± .0010 ANGLE ± 1° 00'		<b>EMERSON</b> Network Power Connectivity Solutions 299 Johnson Ave. Ste. 100 Waseca, MN 56093 1-800-247-8256	
DRW	C. WALLACE	5/1/14	MATERIAL:	TITLE: BJ770/S/T/U/V/ W/X/Y/Z	
CHK	P. KLYVE	5/2/14	FINISH:	SIZE	CAGE CODE
QUALITY				<b>B</b>	<b>14949</b>
MANUF				DRAWING NO.	REV.
APPROVED	C. MONAHAN	2/14/12		<b>C_3-0296</b>	<b>J</b>
PROJ/FILE NO.	3-0296		DO NOT SCALE DWG	SCALE	DATE
				3/1	6/2/95
				SHEET	1 OF 2