

DATA CONTAINED IN THIS DOCUMENT IS PROPRIETARY TO EMERSON CONNECTIVITY SOLUTIONS AND SHALL NOT BE DISCLOSED, COPIED OR USED FOR PROCUREMENT OR MANUFACTURE WITHOUT EXPRESS WRITTEN PERMISSION

REVISIONS			
REV	DESCRIPTIONS	DATE	APPROVED
H	ECO 53006	2/7/11	T. KOHLER

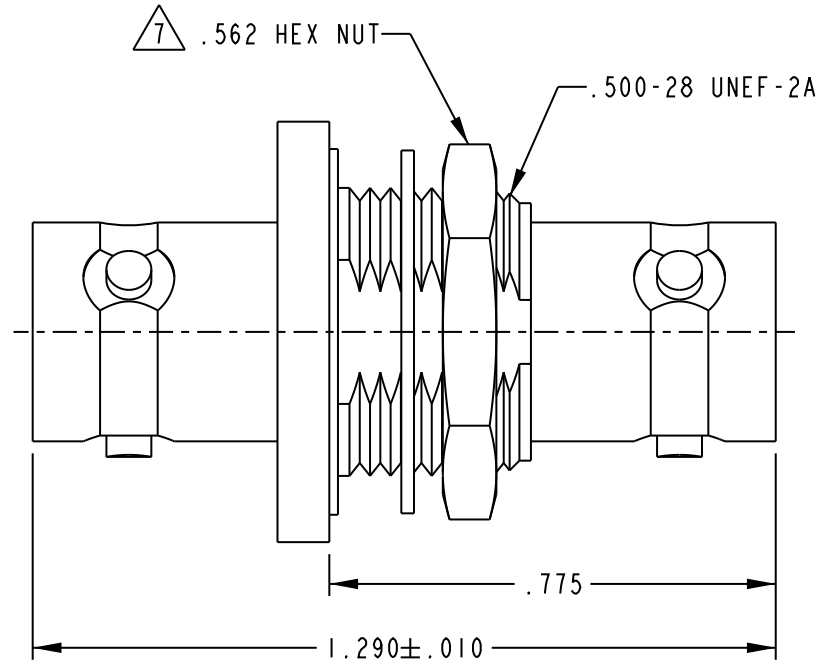

BJ78HS SHOWN

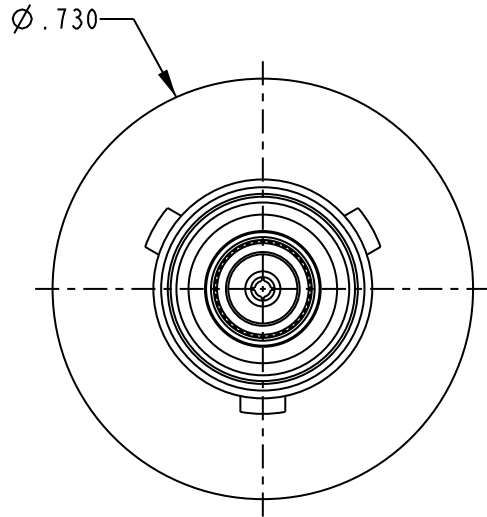
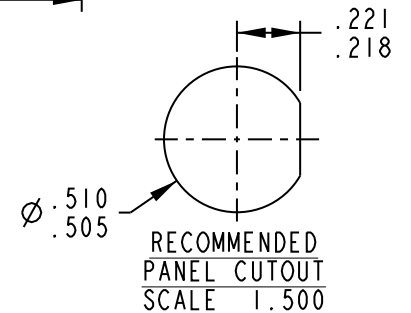

- △ 7. FOR BJ78HSS, 5/8 HEX NUT.
- 6. FOR BJ78HSS, REPLACE 8-1520-17 WITH 805-1304-3
- 5. MATERIAL & CONSTRUCTION: MEET THE REQUIREMENTS OF MIL-C-49142 WHERE APPLICABLE.
- 4. DIELECTRIC WITHSTANDING VOLTAGE: 500 V COMMON MADE VOLTAGE BETWEEN CIRCUITS.
- 3. LEAK RATE: 1×10^{-8} CC/SEC MAX OF TRACER GAS AT ATMOSPHERIC PRESURE.
- 2. HERMETICALLY SEALED TWINAX/TRIAx FEED THRU ADAPTER FOR MOUNTING IN BULKHEAD .187 THK MAX.
- △ 1. PASSIVATED STAINLESS STEEL.

NOTES: UNLESS OTHERWISE SPECIFIED.

INTERPRET DRAWING PER MIL-STD-100. DIMENSIONS ARE IN INCHES AND INCLUDE FINISH THICKNESS UNLESS OTHERWISE SPECIFIED.		TOL: UNLESS SPECIFIED. .XX ± .XXX ± .005 .XXXX ± ANGLE ±		 Cinch Connectivity Solutions 299 Johnson Ave, Ste. 100 Waseca, MN 56093 1-800-247-8256	
DRW C. WALLACE	4/7/11	MATERIAL: △ 1		TITLE: BJ78HS, BJ78HSS	
CHK T. KOHLER	4/8/11	FINISH: △ 1		SIZE △	CAGE CODE 14949
QUALITY		DRIVING NO. 305-0063	REV. H		
MANUF		DATE 5/5/11	SHEET 1 OF 2		
APPROVED		DO NOT SCALE DWG	SCALE 2/1		
SURFACE AREA	PROJ TITLE NO. 305-0063				