

Confidential

Control Number

SP-BK-26SCSA01-01-01

Issued on:

17th. Oct. 2016

To: Panasonic Industrial Sales Company of America

Delivery Specification

Products Name: Sealed Nickel Metal Hydride Rechargeable Battery

Customer P/N: —

Panasonic P/N: BK-26SCSA01

Received by Customer

Received on:

Panasonic Corporation
Automotive & Industrial Systems Company
Energy Device Business Division
Panasonic Energy (Wuxi) Co.,Ltd.

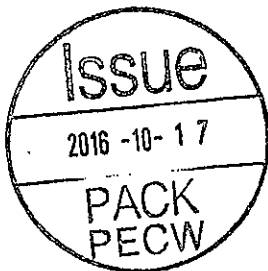

Panasonic Energy (Wuxi) Co.,Ltd.		
Approved	Checked	Prepared

SEALED NICKEL METAL HYDRIDE BATTERIES

BK-26SCSA01 Specification

1. Application Range

Panasonic Industrial Sales Company of

This specification applies to the Sealed Nickel Metal Hydride Rechargeable Batteries for Americal

2. Rating specification

o Model	BK260SCS
o IEC designation	HR23/43 (Cell)
o Nominal Voltage	1.2 V
o Rating (minimum)Capacity	2450 m A h
o Average Capacity (for reference only)	2700 m A h
o Standard Charge Rate	245 m A × 1 6 hours
o Rapid Charge Rate	2600 m A (with the following charge conditions)

(charge condition)

Value of dT/dt(for reference only)	1 ~ 2 °C / m i n
Value of -ΔV per cell	5 ~ 10 m V (Cell)
Value of Tco	60 °C
Trickle current with timer	82 ~ 123 m A (with timer)

All rapid charge systems should be discussed with our engineer.

o Standard Discharging	490 m A
o Discharge Cut-off Voltage	1.0 V

(When you use single battery by series, refer to "Cautions of the design of battery-operated products 5-4".)

o Maximum Continuous Discharge Current	30000 m A (20°C、single cell)
o Operating Temperature Range(Ta)	(Humidity : +65 %±20 %)
Standard charge	0°C ≦ Ta ≦ +45 °C (32 ≦ Ta ≦ 113 ° F)
Rapid charge	0°C ≦ Ta ≦ +40 °C (32 ≦ Ta ≦ 104 ° F)
Discharge	-10°C ≦ Ta ≦ +65 °C (14 ≦ Ta ≦ 149 ° F)
o Storage Temperature Range(Ta)	(Humidity : +65 %±20 %)
within 1 year	-20°C ≦ Ta < +35°C (-4 ≦ Ta < 95 ° F)
within 6 months	-20°C ≦ Ta < +45 °C (-4 ≦ Ta < 113 ° F)
within 1 month	-20°C ≦ Ta < +55 °C (-4 ≦ Ta < 131 ° F)
within 1 week	-20°C ≦ Ta ≦ +65 °C (-4 ≦ Ta ≦ 149 ° F)

Rated capacity figures are based on single cell performance.

We recommend cells or batteries are charged at least once every year (if possible every 6 months).

In use or storage, avoide condensation.

Discuss about a condition of above outside separately.

3. Assembly & Dimension

Drawing No.

W21260463

Cell is composed with Positive electrode, Negative electrode, Separator, and Steel case. Positive and Negative electrode is separated by Separator, and received in case, closed up by Positive electrode collector.

Positive electrode collector is composed with Cap, Sealing plate and Insulation ring.. Case is negative and is covered by tube or label.

4. Test

4 - 1 Test Condition

- (1) All tests are carried out on new cells or batteries. (within one month after delivery)
- (2) Ambient conditions :
- | | |
|-------------|-------------|
| Temperature | +20 °C±5 °C |
| Humidity | +65 %±20 % |

4 - 2 Test method and judgment criteria. Refer to appended table.

5. Others

5 - 1 Packing state

- o The cell or battery shall be **charged state** at shipping.

5 - 2 Cut-off voltage

- o We recommend a cut-off voltage of 1.0 to 1.1 V per cell.
- o If the cut-off voltage is above 1.1 V per cell, the battery may be underutilized resulting in insufficient use of the available capacity
- o If the cell voltage drops below 1.0 V per cell, the battery may become over discharged or reverse charged.
In case of over 2It mA discharge a cut-off voltage should be 0.8 V per cell.

5 - 3 Change of specification

- o When change of specification contents is necessary, change is determined through mutual sincere consultation
- o
- o

5 - 4 Note of export and import

- o When your company export and import to other country, it may not comply with the local laws and regulations. on triff,environment,quality, etc. In this situation, your compnay needs to handle all these concerns.
- o Futhermore, all the documents that your company issued for the porpose of exporting the product should also comply with the above laws and regulations. Our company wil not be responsible for your loss caused by legal problems.

5-5 Country of origin

- o China

6. Prohibition items in handling battery packs for safety

Panasonic corporation AIS company can not take responsibility for troubles occurred in handling as the followings

6 - 1 Disassembling of the battery pack and cell

Do not disassemble the battery pack and cell.

Because an electrolyte is strong alkalinity, it can moun of over skin and a wearing apparel.

6 - 2 Externally short circuit of the battery pack

Do not externally short-circuited the battery pack. If externally short-circuited , the battery pack may be heated, ignited or broken.

6 - 3 Throwing into fire of the battery pack

If battery pack thrown into the fire, the battery pack may be ignited or broken. Olso if battery pack thrown into the water, the battery may be lost the function.

6 - 4 Soldering

Do not solder to battery. There is a fear of destruction of safe mechanism by the damage of a relief valve in a battery cap.

6 - 5 Incorrect inserting

Do not reverse of battery pack + - .There is a fear of ignition and explosion of a battery.

6 - 6 Over charge,inverse charge in high current

- ① Do not charged,over-charge or inverse-charge in higher current than specified. Gas may be quickly generated in the cell inside, causing ignition or breakage
- ② Charging by not specified chargers or modified chargers being specified may cause heating,igniting and breaking. Please specify as a prohibition matter for safe security to handling instructions by all means.
- ③ If a deep discharge by a long-term strage of remains connected for an extended period and equipment battery and tern the camera off after the equipment switched. there is a risk that performance,life is extermely low or to leak. To prevent these overdischarge, please be sure to provide a deep discharge mechanism. At the same time, leakage current to the main unit from the battery, please enter a few μA or less. Also please aviod the shippment of and attached to the main body of the battery.

6 - 7 Mounting to units

Do not mount in close structure. Combustibles released from cells in operating the safety mechanism may take fire by sparks generated by the motor,switches,etc. Take notice to immediatly release combustible from the units.

6 - 8 Use for other usage

Do not use battery pack to other units or for other usage. Specification difference may damage battery pack or break units.

< Appendix : Standard test method & criteria

(Notes) Although the basic unit cell specification, if the number N of cells in series configuration, the test method, the voltage and the resistance value(except in the case of an insulating) of the standard is N times.
Unless otherwise stated, discharge cut-off voltage is 1.0v / cell.

Item	Test Method	Judgment Criteria
1. Appearance / Indication	Visual inspection	There are not excessive dirt, deformation & flaws Indication is according to appended drawing
2. Dimension	Measure by calipers.	According to appended drawing
3. Insulation resistance (Cell)	Measure by insulation resistance meter between outer jacket and terminal.	more than 10 MΩ
4. Weight (Cell)	Measure by balance	Approx. weight 52 g
5. Charge voltage (Cell)	Following the pre-discharging and the quick charging , and measure the voltage for less than 5 minutes before the charge end. Pre-discharging : Discharge until cut-off voltage at 2450 mA	1.8 v / cell or less
6. Open circuit voltage (Cell)	Measure open circuit voltage within 1 hour after standard charging	1.25 v / cell or more
7. Close circuit voltage (Cell)	Measure close circuit voltage within 1 hour after standard charging Constant resistive load 0.40 Ω/cell	The close circuit voltage for measurement start less than 1 second 1.2 v / cell or more
8. Internal resistance (Cell)	Measure internal resistance within 1 hour after standard charging	7 mΩ / cell or less.
9. Capacity (Cell)	Measure capacity by discharging in standard discharging current within 1 hour after standard charging (It Can repeat a test to amount to 3 cycle when does not satisfy the first time standard.)	Rating capacity or more.
10. High rate discharging (Cell)	Measure discharging time by holding for 1hour after standard charging and discharging at 2450 mA to 0.9V(cell voltage)	48 minutes or more.
11. Low temperature discharging (Cell)	Measure discharging time by holding at 0°C±2°C for 24 hours after standard charging and standard discharging.	3 hours 00 minutes or more

Item	Test Method	Judgment Criteria																															
12. Capacity storage (Cell)	A standard charged the battery which was over of capacity test of 9, and a standard discharged after leave for 28 days, and measure discharging time.	3 hours 00 minutes or more																															
13. storage (Cell)	Battery of discharged condition hold open circuit state for 12 months. Measure discharging time after capacity test of 9.	4 hours 00 minutes or more																															
14. Over charge (Cell)	After standard discharging and following a 48hours continuous overcharge period at 245 mA the cell shall be stored for a period of 1 hour. Measure standard discharging time.	No deformation and leakage. 5 hours 00 minutes or more																															
15. Life time JIS C8708(2007) (Cell)	<table border="1" style="width: 100%; border-collapse: collapse;"> <tr> <td colspan="4" data-bbox="370 631 1083 788">Repeat cycle examinations from 1 to 50 as a 1 unit and measure discharge time.</td> </tr> <tr> <td data-bbox="370 788 512 871">1 : charge</td> <td data-bbox="512 788 608 871">245</td> <td data-bbox="608 788 927 871">mA 1 6 hours</td> <td data-bbox="927 788 1083 871" rowspan="3">Do not hold by a charge state</td> </tr> <tr> <td data-bbox="370 871 512 954">: discharge</td> <td data-bbox="512 871 608 954">613</td> <td data-bbox="608 871 927 954">mA 2 hours 2 0 minutes</td> </tr> <tr> <td data-bbox="370 954 512 1037">2~48 : charge</td> <td data-bbox="512 954 608 1037">613</td> <td data-bbox="608 954 927 1037">mA 3 hours 1 0 minutes</td> </tr> <tr> <td data-bbox="370 1037 512 1120">: discharge</td> <td data-bbox="512 1037 608 1120">613</td> <td data-bbox="608 1037 927 1120">mA 2 hours 2 0 minutes</td> <td data-bbox="927 1037 1083 1120" rowspan="2">Hold for 1~4hours by a charge state</td> </tr> <tr> <td data-bbox="370 1120 512 1202">49 : charge</td> <td data-bbox="512 1120 608 1202">613</td> <td data-bbox="608 1120 927 1202">mA 3 hours 1 0 minutes</td> </tr> <tr> <td data-bbox="370 1202 512 1285">: discharge</td> <td data-bbox="512 1202 608 1285">613</td> <td data-bbox="608 1202 927 1285">mA Until the battery voltage 1.0v</td> </tr> <tr> <td data-bbox="370 1285 512 1368">50 : charge</td> <td data-bbox="512 1285 608 1368">245</td> <td data-bbox="608 1285 927 1368">mA 1 6 hours</td> <td data-bbox="927 1285 1083 1368" rowspan="2">Hold for 1~4hours by a charge state</td> </tr> <tr> <td data-bbox="370 1368 512 1451">: discharge</td> <td data-bbox="512 1368 608 1451">490</td> <td data-bbox="608 1368 927 1451">mA Until the battery voltage 1.0v</td> </tr> </table>	Repeat cycle examinations from 1 to 50 as a 1 unit and measure discharge time.				1 : charge	245	mA 1 6 hours	Do not hold by a charge state	: discharge	613	mA 2 hours 2 0 minutes	2~48 : charge	613	mA 3 hours 1 0 minutes	: discharge	613	mA 2 hours 2 0 minutes	Hold for 1~4hours by a charge state	49 : charge	613	mA 3 hours 1 0 minutes	: discharge	613	mA Until the battery voltage 1.0v	50 : charge	245	mA 1 6 hours	Hold for 1~4hours by a charge state	: discharge	490	mA Until the battery voltage 1.0v	Discharge time after 500 cycles 3 hours 00 minutes or more
Repeat cycle examinations from 1 to 50 as a 1 unit and measure discharge time.																																	
1 : charge	245	mA 1 6 hours	Do not hold by a charge state																														
: discharge	613	mA 2 hours 2 0 minutes																															
2~48 : charge	613	mA 3 hours 1 0 minutes																															
: discharge	613	mA 2 hours 2 0 minutes	Hold for 1~4hours by a charge state																														
49 : charge	613	mA 3 hours 1 0 minutes																															
: discharge	613	mA Until the battery voltage 1.0v																															
50 : charge	245	mA 1 6 hours	Hold for 1~4hours by a charge state																														
: discharge	490	mA Until the battery voltage 1.0v																															
16. Life time (Cell)	Charge and discharge cycles is repeated in the below condition. And measure discharge time at 2450 mA •Discharge: 2450 mA up to cut-off voltage •Charge:Depend on quick charging specification shown by 2:Rating specification.	Discharge time after 300 cycles 36 minutes or more.																															
17. Leakage (Cell)	Leave in the atmosphere at temperature 40±2°C, humidity 93 ± 3% for 21days after standard charging and pre-discharge.	Leakage is not detected in visual inspection																															
18. Vibration (Cell)	After standard charging, do the test under below conditions •Cycle 10H z — 500H z •Amplitude 0.35 mm or max.50m/s2 •Sweep speed 1 octave/min. •Sweep cycle 5 cycles •Axes Three axes to be perpendicular to each other (XYZ)	After standard discharging to 1.0v/cell, 4days later check the capacity(Item.9) 5 hours 00 minutes or more No leakage of electrolyte in liquid form and no venting shall be observed.																															
19. Drop (Cell)	Store for 1~4 hours after standard charging, After that, do the test under below conditions •Hight 1000 mm •Surface Hardwood •Cycle Each twice for three axes to be perpendicular to each other (XYZ)	After standard discharging to 1.0v/cell, 4days later check the capacity(Item.9) 5 hours 00 minutes or more No leakage of electrolyte in liquid form and no venting shall be observed.																															

Item	Test Method	Judgment Criteria	
20. Short circuit (Cell)	After standard charging, short circuit for an hour through a lead with the shortest length between + and -	The battery must not explode, Leakage, defomation and rupturing of the exterior tubing are acceptable	
21. Reverse charging (Cell)	Reversecharge the battery at 2450 mA for 1 hour.		
22. Over charging (Cell)	Overcharge the battery at 2450 mA for 5 hours.		

Ni-MH Battery ; Example on rapid charge system

1. Basic charge system

①	Rapid charge current	0.5It to 1.0It mA
②	Charge current to voltage for rapid charge	0.2It to 0.3It mA
③	Start voltage of rapid charge	above 0.8 V per cell
④	Upper limit voltage (to trickle charge)	1.8 V per cell
⑤	Value of minus delta V (-ΔV)	5 to 10 mV per cell
⑥	Temperature increase rate (dT/dt)	1 to 2 °C/min
⑦	Upper limit temperature (Tco)	60 °C
⑧	Initial non-detection timer of minus delta V(-ΔV)	5 to 10 min
⑨	Trickle charge current	1/30It to 1/20It mA
⑩	Transfer timer to rapid charge	60 min
⑪	Total rapid charge timer	1.5 h
⑫	Total charge timer	10 to 20 h
⑬	Ambient temperature for rapid charge	0 to 40 °C

※ Matching test is necessary because it depends on the fast-charge current, cell number, pack shape etc.

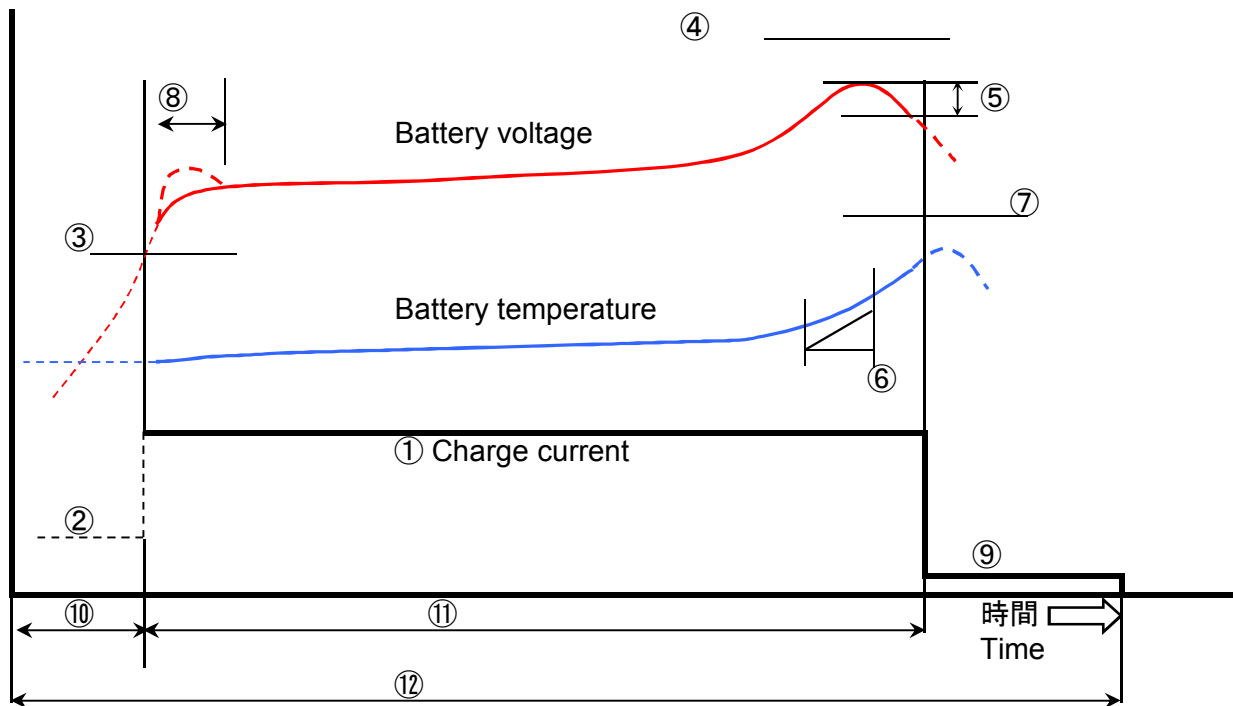

2. Basic pack circuit

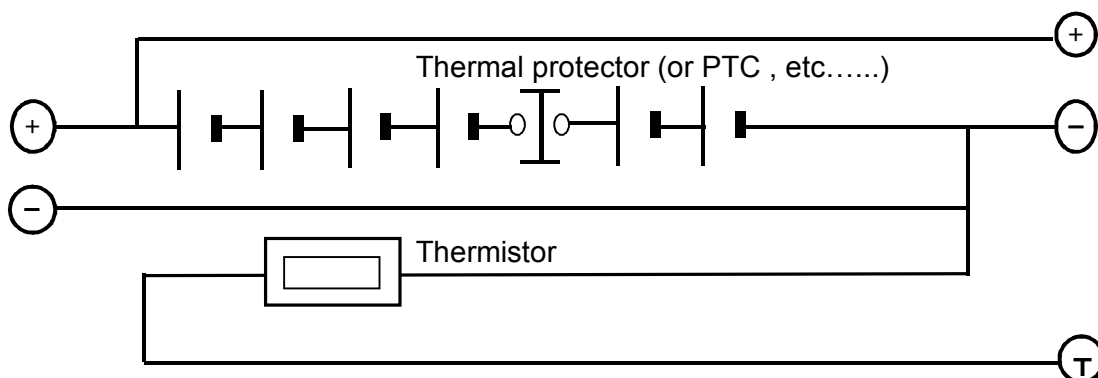

<<Sealed Type Nickel-Metal Hydride Rechargeable Battery>>

Cautions concerning the use of the batteries and the design of battery-operated products

When using these batteries and when designing battery-operated products, please pay particular attention to the following points in order to take full advantage of the batteries' characteristics, and to prevent problems due to improper use.

Panasonic assumes no responsibility for quality problems or troubles resulting from use that does not conform to the “Cautions concerning the use of the batteries and the design of battery-operated products” shown below.

When this mention contents and individual specifications are not equal, individual specifications contents are given priority to.

- | | | |
|---|--|---|
| 1 | Charging | <ul style="list-style-type: none"> 1 – 1 Charging temperature 1 – 2 Parallel charging of batteries 1 – 3 Reverse charging 1 – 4 Overcharging 1 – 5 Rapid charging 1 – 6 Trickle charging (continuous charging) |
| 2 | Discharging | <ul style="list-style-type: none"> 2 – 1 Discharging temperature 2 – 2 Overdischarging (deep discharge) 2 – 3 High-current discharging |
| 3 | Storage | <ul style="list-style-type: none"> 3 – 1 Storage temperature and humidity 3 – 2 Long-term storage |
| 4 | Service life of batteries | <ul style="list-style-type: none"> 4 – 1 Cycle life 4 – 2 Service life with long-term use |
| 5 | Design of products which use batteries | <ul style="list-style-type: none"> 5 – 1 Connecting batteries and produc 5 – 2 Material for terminals in products using the batteries 5 – 3 Position and temperature of batteries in products 5 – 4 Discharge end voltage 5 – 5 Overdischarge (deep discharge) prevention |
| 6 | Restrictions regarding battery handling in order to ensure safety | <ul style="list-style-type: none"> 6 – 1 Disassembly 6 – 2 Short-circuiting 6 – 3 Throwing batteries into a fire or water 6 – 4 Soldering 6 – 5 Inserting the batteries with their polarities reversed 6 – 6 Overcharging at high currents and reverse charging 6 – 7 Installation in equipment (with a sealed construction) 6 – 8 Use of batteries for other purposes 6 – 9 Short-circuiting of battery packs 6 – 1 Using old and new batteries together |
| 7 | Other precautions | <ul style="list-style-type: none"> 7 – 1 Charging before use |
| 8 | Requests | Please pay particular attention to underlined text. |

1 – 1 Charging temperature

- ① Charge batteries within an ambient temperature range of 0°C to +40°C.
- ② The ambient temperature during charging affects the charging efficiency. Since the charging efficiency is best within a temperature range of +10°C to +30°C, whenever possible place the charger (battery pack) in a location within this temperature range
- ③ At temperatures below 0°C, the gas absorption reaction is not adequate, causing the gas pressure inside the battery to rise, which can activate the safety vent and lead to leakage of alkaline gas and deterioration of the battery performance.
- ④ The charging efficiency drops at temperatures above +40°C.
This can impact the full charging and lead to deterioration in performance and battery leakage.

1 – 2 Parallel charging of batteries

- When charging batteries connected in parallel, sufficient attention should be paid to the design of the charger, including temperature variations depending on the number of batteries charged.
Consult Panasonic when parallel charging is required.

1 – 3 **Reverse charging**

- **Never carry out reverse charging.**
Charging with reversed polarities can cause a reversal in a battery's polarity, causing the gas pressure inside the battery to rise, which can activate the safety vent and cause a rapid deterioration in battery performance, even battery swelling and battery rupture.

1 – 4 **Overcharging**

- **Avoid overcharging.**
Repeated overcharging can lead to deterioration in battery performance.
(Overcharging means charging a battery when it is already fully charged.)

1 – 5 **Rapid charging**

- **To charge batteries rapidly, use the specified charger (or charging method recommended by Panasonic) and follow the correct procedures.**

1 – 6 Trickle charging (continuous charging)

- ① When adopting trickle charging as the standard charging method, use the H or O type batteries.
Charge the batteries at a current from 1/30 ItmA to 1/20 ItmA.
- ② When adopting trickle charging as a supplementary charging method after rapid charging, carry out trickle charging at a current from 1/30 ItmA to 1/20 ItmA.
To avoid the deterioration of a battery's performance due to overcharging, use a timer that measures the total charging time including trickle charging.

* Note: "It mA" During charging and discharging, ItmA is a value indicating current and expressed as a multiple of nominal capacity. Substitute "It" with the battery's nominal capacity when calculating.
For example,
for a 1500mAh battery of 1/30 ItmA, this value is equal to $1/30 \times 1500$, or roughly 50mA.

2 – 1 Discharging temperature

- ① Discharge batteries within an ambient temperature range of -10°C to $+65^{\circ}\text{C}$.
- ② The level of the discharge current (i. e., the current at which a battery is discharged) affects the discharging efficiency. The discharging efficiency is satisfactory within a current range of $1/10 I_{\text{mA}}$ to $1/2 I_{\text{mA}}$.
- ③ Discharging batteries at temperatures below -10°C or above $+65^{\circ}\text{C}$ can lead to the deterioration in the battery's performance.
- ④ Even at the maximum discharge current or lower, discharging may be impossible at a low temperature.

2 – 2 **Overdischarging (deep discharge)**

Because overdischarging (deep discharging) damages the battery and causes electrolyte leakage, do not forget to turn off the switch when discharging, and do not leave the battery connected to the equipment for long periods of time. Also, avoid shipping the battery installed in the equipment

2 – 3 High-current discharging

- ① When discharging at a high current, use the P or X type batteries.
- ② Because high-current discharging can lead to heat generation and decreased discharging efficiency, consult Panasonic before attempting continuous discharging or pulse discharging at currents greater than $2 I_{\text{mA}}$.

3 Storage

3 – 1 Storage temperature and humidity (short-term)

- ① Store batteries in a dry location with low humidity, no corrosive gases, and a temperature range of -20°C to $+45^{\circ}\text{C}$.
- ② Storing batteries in a location where humidity is extremely high or temperatures fall below -20°C or rise above $+45^{\circ}\text{C}$ leads to the rusting of metallic parts and battery leakage due to expansion or contraction in parts composed of organic materials.

3 – 2 Long-term storage (1 year, -20°C to $+35^{\circ}\text{C}$)

- ① Long-term storage may cause the deterioration of various characteristic. Therefore, it is desirable to store the batteries at as a low temperature as much as possible.
- ② When charging for the first time after long-term storage, deactivation of reactants may have led to increased battery voltage and decreased battery capacity. Restore such batteries to their original performance through repeated several cycles of charging and discharging.
- ③ When storing batteries for more than 1 year, charge once every six months or at least once a year to prevent leakage and deterioration in performance due to self-discharging.

4 – 1 Cycle life

The life of a battery is 500 cycles or more of operation under the durability test conditions specified by JIS. A significantly reduced service time in spite of proper charging means that the life of the battery has been exceeded.

Also, at the end of service life, an unusual increase in internal resistance, or an internal short-circuit may occur. Chargers and charging circuits should therefore be designed to ensure safety in the event of failure heat generated upon battery failure at the end of service life. (if any points are unclear, contact Panasonic.)

4 – 2 Service life with long-term use

As batteries are chemical products involving internal chemical reactions, performance deteriorates not only with use, but also during prolonged storage.

Normally, a battery will last 2 to 3 years (or 500 cycles) if used under proper conditions and not overcharged or overdischarged. Note that failure to satisfy the proper conditions concerning charging, discharging, temperature, and other factors during actual use can cause electrolyte leakage, leading to the deterioration of a battery's performance or damage to products, and shorten the battery's service life (or cycle life).

5 – 1 Connecting batteries and products

- ① **Never solder a lead wire or other connecting materials directly to the battery, because doing so will damage the battery's internal safety vent, separator, and other parts made of organic materials. To connect a battery to a product through soldering, solder the lead wire to a contact piece (tab) made of nickel or nickel-plated steel, and then spot-weld the tab to the battery.**
- ② **To connect the terminal of a product to the terminal of a battery pack by contact rather than using a connector, the terminal shapes and the contact pressure should be carefully designed to prevent contact failures.**

5 – 2 Material for terminals in products using the batteries

- **As small amounts of alkaline electrolyte can leak out from the battery seal during extended use or when the safety vent is activated during improper use, use a highly alkaline-resistant material for the product's contact terminals in order to avoid problems due to corrosion.**

5 – 3 Position and temperature of batteries in products

- As excessively high temperatures (i. e., higher than 65°C) can cause alkaline electrolyte to leak out from the battery, thus damaging the product and shorten battery life by causing deterioration in the separator or other battery parts, install the batteries far from the heat-generating parts of products. The best battery position is a battery compartment made of an alkaline-resistant material and that isolates the batteries from the product's circuitry. This prevents damage caused by slight leakages of alkaline electrolyte from the battery.

5 – 4 Discharge end voltage

The basic discharge end voltage is determined by the formula given below.

Number of batteries arranged serially

1 to 6: (Number of batteries × 1.0) V

7 to 10 : [(Number of batteries – 1) × 1.2] V

The discharge end voltage should be set in accordance with the number of cells in a battery pack and the discharge current. When you require a battery pack whose discharge current is 2 ItmA or more or includes more than 11 cells, please consult Panasonic.

5 – 5 Overdischarge (deep discharge) prevention

Overdischarging (deep discharging) or reverse charging deteriorates a battery's performance, leading to electrolyte leakage or deterioration of product performance. To avoid these problems, make sure to provide the product with a mechanism to prevent overdischarging (deep discharging). Further, minimize the leakage current from the battery to the product to several microamperes or less.

6 – 1 Disassembly

- Never disassemble a battery, as the electrolyte inside is strong alkaline and can damage skin and clothes.

6 – 2 Short-circuiting

- Never attempt to short-circuit a battery. Doing so can damage the product and generate heat that can cause burns.

6 – 3 Throwing batteries into a fire or water

- Disposing of a battery in fire can cause the battery to rupture. Also avoid placing batteries in water, as this damages battery functions.

6 – 4 Soldering

- Never solder anything directly to a battery. This can destroy the safety features of the battery by damaging the safety vent inside the cap.

6 – 5 Inserting the batteries with their polarities reversed

- Never insert a battery with the positive and negative poles reversed, as this can cause the battery to swell or rupture.

6 – 6 Overcharging at high currents and reverse charging

- ① Never carry out reverse charging or overcharging with high currents (i. e., higher than rated). Doing so causes rapid gas generation and increased gas pressure, thus causing batteries to swell or rupture.
 - ② Charging with an unspecified charger or a specified charger that has been modified can cause batteries to swell or rupture.
- ☆ Be sure to indicate this safety warning clearly in all operating instructions as a handling restriction for ensuring safety

6 – 7 Installation in equipment (with a sealed construction)

- Always avoid incorporating batteries into a product with a sealed construction. In some cases, gases (oxygen, hydrogen) may be generated, and there is a danger of the batteries bursting or rupturing in the presence of a source of ignition (sparks generated by a motor, switch, etc.).

6 – 8 Use of batteries for other purposes

- Do not use a battery for an appliance or purpose for which it was not intended. Differences in specifications can lead to damage to the battery or appliance.

6 – 9 Short-circuiting of battery packs

- Take special care to prevent battery packs from short-circuiting. There is a possibility that cassette type battery packs may be inserted in a reverse direction depending on the shape of the product or battery. In addition, some shapes of product terminals are more likely to cause short-circuiting. Therefore, special care should be taken.

6 – 1 0 Using old and new batteries together

- Avoid using old and new batteries together. Also avoid using these batteries with ordinary dry-cell batteries, Ni-Cd batteries or with another manufacturer's batteries. Differences in the characteristics can damage the batteries or the product.

7 – 1 Charging before use

- Batteries should always be charged prior to use. Be sure to charge them correctly.

8 **Requests**

- ※ **Battery performance and service life vary largely with usage.**
When you design a battery-operated product, please consult Panasonic regarding the charging and discharging specifications and the product structure to ensure safety.
- ※ About regulations outside specifications, it follows another individual specifications.

Panasonic assumes no responsibility for quality problems or troubles resulting from use that does not conform to the “Cautions concerning use and the design of battery-operated products” shown above.

**Quality Assurance Department
Energy Device Business Division
Automotive & Industrial Systems Company
Panasonic Corporation**

**1-1, Matsushita-cho, Moriguchi City, Osaka Japan 570-8511
Tel: +81 - (0) - 6 - 6994 - 4651**

FOR MESSRS : Panasonic Industrial Sales Company of Americal

< Warranty >

- 1) The Battery Packs are warranted to conform to the descriptions contained in this specifications for a period of twelve (12) months from the ex-factory date.
In the event that a Battery Pack fails to comply with the Specifications and the cause of which was attributable to Panasonic Corporation's fault during the said warranty period, Panasonic Corporation will repair such non-conforming battery pack, or supply a replacement Battery Pack, either way agreed by both parties.
- 2) Please assure full responsibility for matching and reliability of Battery Packs on actual set or unit application.
- 3) Panasonic Corporation's warranty shall not be applicable in the case where customer fails to carry out proper handling, operating, installation, testing, service and checkout of the battery Packs and/or to follow the instructions, cautions, warnings, notes provided in this specifications, or other reasonable methods.

Quality Assurance Department
Energy Device Business Division
Automotive & Industrial Systems Company
Panasonic Corporation
1-1, Matsushita-cho, Moriguchi City, Osaka Japan 570-8511
Tel: +81-(0)-6-6994-4651

Symbol	Date	Revision	Drawn	Checked	Checked

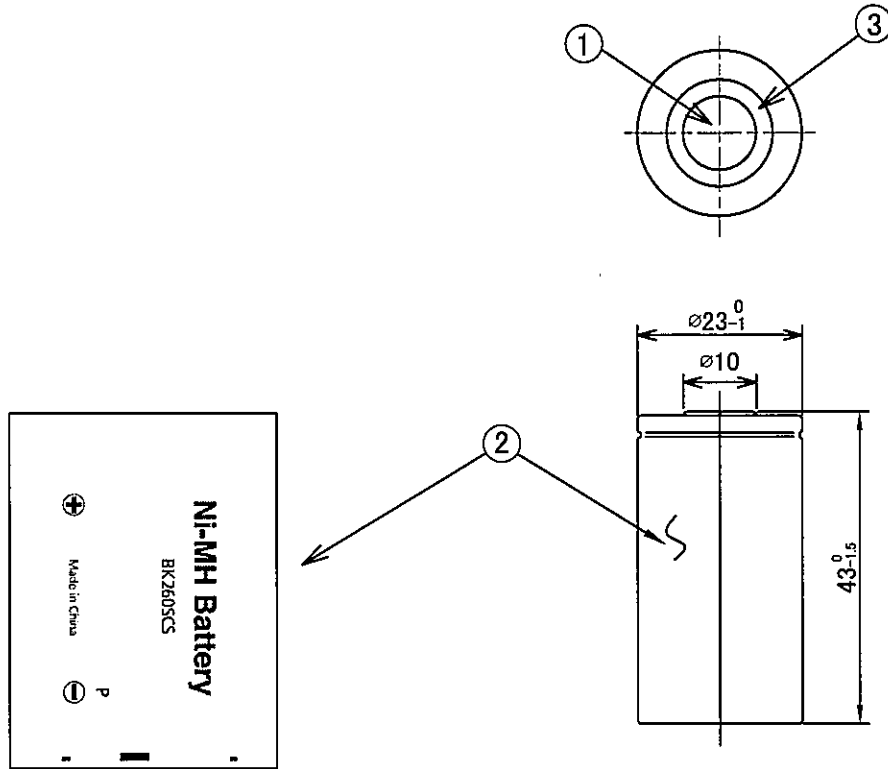

HEAT STAMP : DATE CODE (RANDOM)

EX: 13 08
 T T
 YEAR MONTH

NOMINAL VOLTAGE : 1.2 V
 RATED CAPACITY : 2450 mAh
 AVERAGE CAPACITY : 2700 mAh
 APPROX WEIGHT : 52 g

秘
 Confidential

3	Insulator Ring	SYNTHETIC PAPER YUPO	1		White
2	Outer Jacket	PVC (Orange)	1	Heat Stamp: Date Code	
1	Cell	BK260SCS	1	Charged	Made in China
Symbol	Name	Material	qt.	Process	Remark

11						Model No.	BK-26SCSA01
Scale	Designed	Drawn	Checked	Checked	Approved	Name	Dimension Sketch 制品图
1:1	Victor	Victor				Parts No.	W21260463
	2016.10.13	2016.10.13					