

Programmable Bluetooth® Low Energy wireless SoC

Features

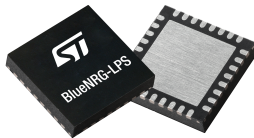

Product status link

[BlueNRG-LPS](#)

Product summary

Order code	BlueNRG-332xy
------------	---------------

- Bluetooth Low Energy system-on-chip supporting Bluetooth 5.3 specifications
 - 2 Mbps data rate
 - Long range (Coded PHY)
 - Advertising extensions
 - Channel selection algorithm #2
 - GATT caching
 - Direction finding (AoA/AoD)
 - LE Ping procedure
 - Periodic advertising and periodic advertising sync transfer
 - LE L2CAP connection-oriented channel
 - LE power control and path loss monitoring
- Radio
 - RX sensitivity level: -97 dBm @ 1 Mbps, -104 dBm @ 125 kbps (long range)
 - Programmable output power up to +8 dBm (at antenna connector)
 - Data rate supported: 2 Mbps, 1 Mbps, 500 kbps and 125 kbps
 - 128 physical connections
 - Integrated balun
 - Support for external PA and LNA
 - BlueNRG core coprocessor (DMA based) for Bluetooth Low Energy timing critical operation
 - 2.4 GHz proprietary radio driver
 - Suitable for systems requiring compliance with the following radio frequency regulations: ETSI EN 300 328, EN 300 440, FCC CFR47 part 15, ARIB STD-T66
- Ultra-low power radio performance
 - 8 nA in SHUTDOWN mode (1.8 V)
 - 0.8 uA in DEEPSTOP mode (with external LSE and BLE wake-up sources, 1.8 V)
 - 1.0 uA in DEEPSTOP mode (with internal LSI and BLE wake-up sources, 1.8 V)
 - 4.3 mA peak current in TX (@ 0 dBm, 3.3 V)
 - 3.4 mA peak current in RX (@ sensitivity level, 3.3V)
- High performance and ultra-low power Arm® Cortex®-M0+ 32-bit, running up to 64 MHz
- Dynamic current consumption: 14 µA/MHz
- Operating supply voltage: from 1.7 to 3.6 V
- -40 °C to 105 °C temperature range
- Supply and reset management
 - High efficiency embedded SMPS step-down converter with intelligent bypass mode
 - Ultra-low power power-on-reset (POR) and power-down-reset (PDR)
 - Programmable voltage detector (PVD)

- Clock sources
 - 64 MHz PLL
 - Fail safe 32 MHz crystal oscillator with integrated trimming capacitors
 - 32 kHz crystal oscillator
 - Internal low-power 32 kHz RO
- On-chip non-volatile Flash memory of 192 kB
- On-chip RAM of 24 kB + 4 kB PKA RAM
- One-time-programmable (OTP) memory area of 1 kB
- Embedded UART bootloader
- Ultra-low power modes with or without timer and RAM retention
- Quadrature decoder
- Enhanced security mechanisms such as:
 - Flash read/write protection
 - SWD disabling
 - Secure bootloader
- Security features
 - True random number generator (RNG)
 - Hardware encryption AES maximum 128-bit security co-processor
 - HW public key accelerator (PKA)
 - Cryptographic algorithms: RSA, Diffie-Helman, ECC over GF(p)
 - CRC calculation unit
 - 64-bit unique ID
- System peripherals
 - 1x DMA controller with 8 channels supporting ADC, SPI-I2S, I2C, USART, LPUART, TIMERS
 - 1x SPI with I2S interface multiplexed
 - 1x I²C (SMBus/PMBus)
 - 1x LPUART (low power)
 - 1x USART (ISO 7816 smartcard mode, IrDA, SPI Master and Modbus)
 - 1x independent WDG
 - 1x real-time clock (RTC)
 - 1x independent SysTick
 - 1x 16-bits, four channel general purpose timer
 - 2x 16-bits, two channel general purpose timer
 - Infrared interface
- Up to 20 fast I/Os
 - All of them with wake-up capability
 - All of them retain state in low-power
 - All of them 5 V tolerant
- Analog peripherals
 - 12-bit ADC with 8 input channels, up to 16 bits with down sampler
 - Battery monitoring
 - Analog watchdog
- Development support
 - Serial wire debug (SWD)
 - 4 breakpoints and 2 watchpoints
- All packages are ECOPACK2 compliant

Applications

- Industrial
- Home and industrial automation
- Asset tracking, ID location, real-time locating system
- Smart lighting
- Fitness, wellness and sports
- Healthcare, consumer medical
- Security/proximity
- Remote control
- Assisted living
- Mobile phone peripherals
- PC peripherals

Description

The BlueNRG-LPS is an ultra-low power programmable Bluetooth® Low Energy wireless SoC solution. It embeds STMicroelectronics's state-of-the-art 2.4 GHz radio IPs, optimized for ultra-low-power consumption and excellent radio performance, for unparalleled battery lifetime. It is compliant with Bluetooth® Low Energy SIG core specification version 5.3 addressing point-to-point connectivity and Bluetooth Mesh networking and allows large-scale device networks to be established in a reliable way. The BlueNRG-LPS is also suitable for 2.4 GHz proprietary radio wireless communication to address ultra-low latency applications.

The BlueNRG-LPS embeds a Arm® Cortex®-M0+ microcontroller that can operate up to 64 MHz and also the BlueNRG core co-processor (DMA based) for Bluetooth Low Energy timing critical operations.

The main Bluetooth® Low Energy 5.3 specification supported features are:

2 Mbps data rate, long range (Coded PHY), advertising extensions, channel selection algorithm #2, GATT caching, Direction Finding (AoA/AoD), hardware support for simultaneous connection, master/slave and multiple roles simultaneously, extended packet length support, LE Ping procedure, periodic advertising and periodic advertising sync transfer, LE power control and path loss monitoring.

In addition, the BlueNRG-LPS provides enhanced security hardware support by dedicated hardware functions:

True random number generator (RNG), encryption AES maximum 128-bit security co-processor, public key accelerator (PKA), CRC calculation unit, 64-bit unique ID, Flash memory read and write protection.

The Public Key Acceleration (PKA) supports the modular arithmetic including exponentiation with maximum modulo size of 3136 bits and the elliptic curves over prime field scalar multiplication, ECDSA signature, ECDSA verification with maximum modulo size of 521 bits CRC calculation unit.

The BlueNRG-LPS can be configured to support standalone or network processor applications. In the first configuration, the BlueNRG-LPS operates as a single device in the application for managing both the application code and the Bluetooth Low Energy stack.

The BlueNRG-LPS embeds high-speed and flexible memory types:

Flash memory of 192 kB, RAM memory of 24 kB, one-time-programmable (OTP) memory area of 1 kB, ROM memory of 7 kB.

Direct data transfer between memory and peripherals and from memory-to-memory is supported by eight DMA channels with a full flexible channel mapping by the DMAMUX peripheral.

The BlueNRG-LPS embeds a 12-bit ADC, allowing measurements of up to eight external sources and up to three internal sources, including battery monitoring and a temperature sensor.

The BlueNRG-LPS has a low-power RTC and three general purpose 16-bit timers.

The BlueNRG-LPS features standard and advanced communication interfaces:

1x SPI/I2S, 1x LPUART, 1x USART supporting ISO 7816 (smartcard mode), IrDA and Modbus mode, 1x I²C supporting SMBus/PMBus.

The BlueNRG-LPS operates in the -40 to +105 °C temperature range from a 1.7 V to 3.6 V power supply. A comprehensive set of power-saving modes enables the design of low-power applications.

The BlueNRG-LPS integrates a high efficiency SMPS step-down converter and an integrated PDR circuitry with a fixed threshold that generates a device reset when the VDD drops under 1.65 V.

The BlueNRG-LPS comes in different package versions supporting up to:

20 I/Os for the QFN32 package. 20 I/Os for the WLCSP36 package.

Figure 1. The BlueNRG-LPS block diagram

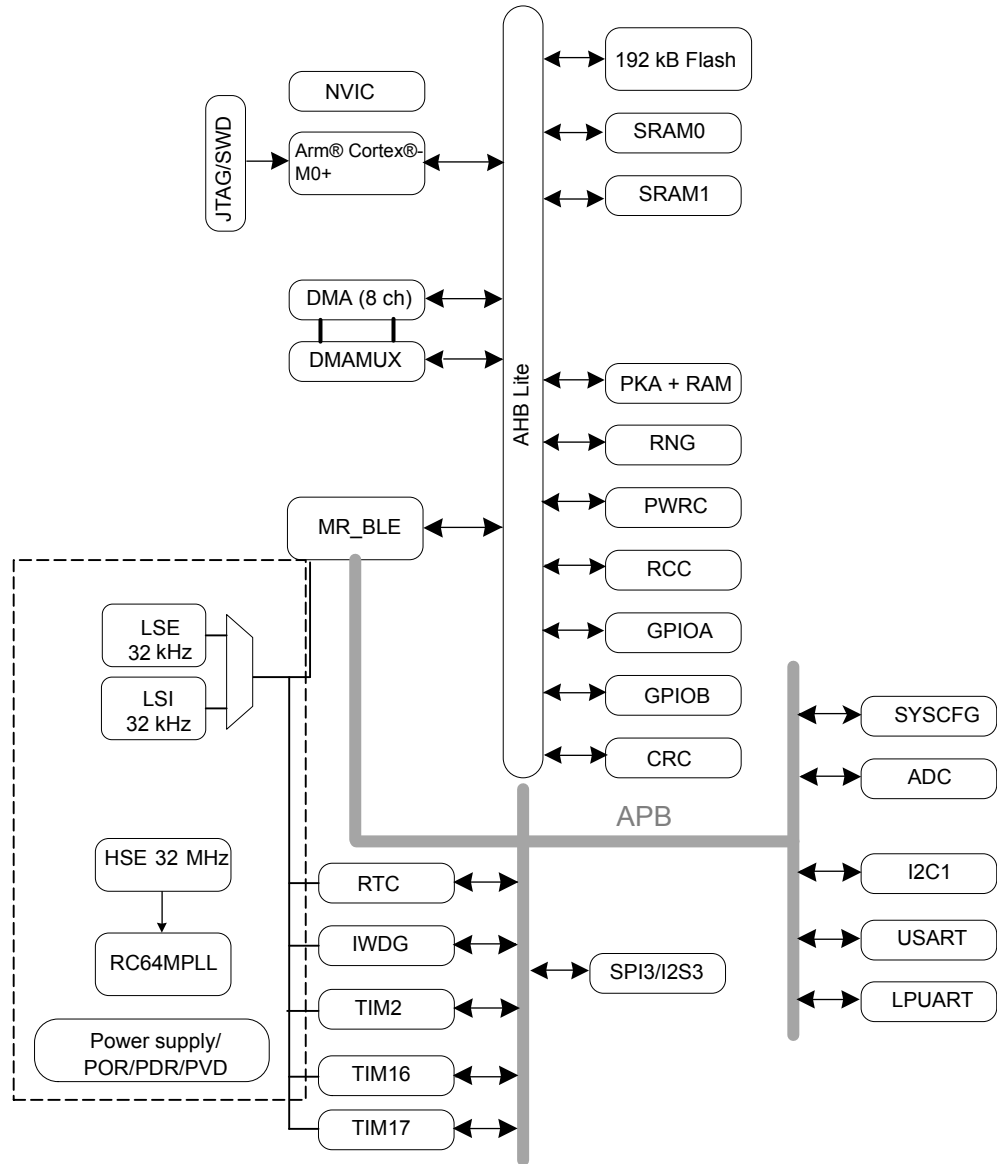

1 Functional overview

1.1 System architecture

The main system consists of 32-bit multilayer AHB bus matrix that interconnects:

- Three masters:
 - CPU (Cortex®-M0+) core S-bus
 - DMA1
 - Radio system
- Seven slaves:
 - Internal Flash memory on CPU (Cortex®-M0+) S bus
 - Internal SRAM0 (12 kB)
 - Internal SRAM1 (12 kB)
 - APB0 peripherals (through an AHB to APB bridge)
 - APB1 peripherals (through an AHB to APB bridge)
 - AHB0 peripherals
 - AHBRF including AHB to APB bridge and radio peripherals (connected to APB2)

The bus matrix provides access from a master to a slave, enabling concurrent access and efficient operation even when several high-speed peripherals work simultaneously.

Figure 2. Bus matrix

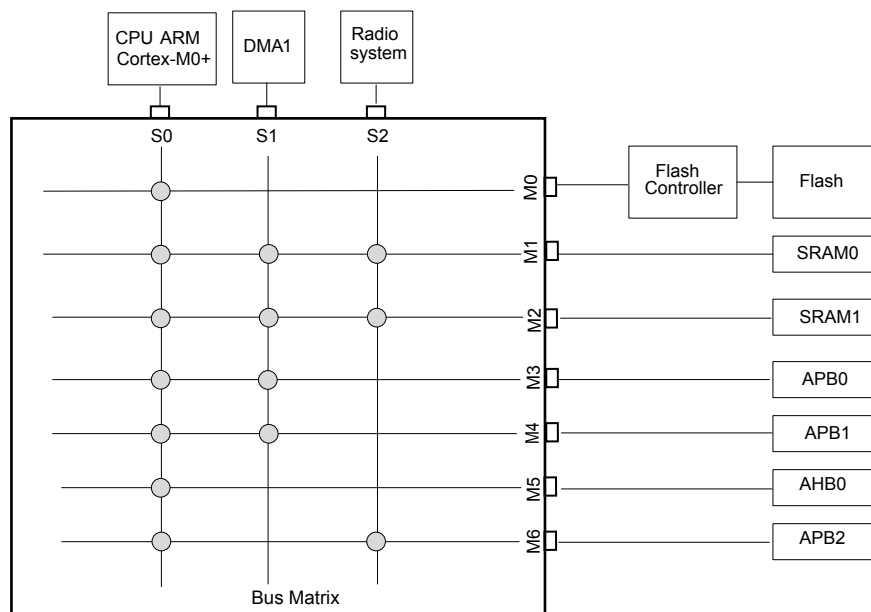

1.2 Arm® Cortex®-M0+ core with MPU

The BlueNRG-LPS contains an Arm® Cortex®-M0+ microcontroller core. The Arm® Cortex®-M0+ was developed to provide a low-cost platform that meets the needs of CPU implementation, with a reduced pin count and low-power consumption, while delivering outstanding computational performance and an advanced response to interrupts. The Arm® Cortex®-M0+ can run from 1 MHz up to 64 MHz.

The Arm® Cortex®-M0+ processor is built on a highly area and power optimized 32-bit processor core, with a 2-stage pipeline Von Neumann architecture. The processor delivers exceptional energy efficiency through a small but powerful instruction set and extensively optimized design, providing high-end processing hardware including a single-cycle multiplier.

The interrupts are handled by the Arm® Cortex®-M0+ Nested Vector Interrupt Controller (NVIC). The NVIC controls specific Arm® Cortex®-M0+ interrupts as well as the BlueNRG-LPS peripheral interrupts. With its embedded ARM core, the BlueNRG-LPS family is compatible with all ARM tools and software.

1.3 Memories

1.3.1 Embedded Flash memory

The Flash controller implements the erase and program Flash memory operation. The flash controller also implements the read and write protection.

The Flash memory features are:

- Memory organization:
 - 1 bank of 192 kB
 - Page size: 2 kB
 - Page number 96
- 32-bit wide data read/write
- Page erase and mass erase

The Flash controller features are:

- Flash memory read operations: single read or mass read
- Flash memory write operations: single data write or 4x32-bits burst write or mass write
- Flash memory erase operations: page erase or mass erase
- Page write protect mechanism: 4 variable-size memory segments

1.3.2 Embedded SRAM

The BlueNRG-LPS has a total of 24 kB of embedded SRAM, split into two banks as shown in the following table:

Table 1. SRAM overview

SRAM bank	Size	Address	Retained in DEEPSTOP
SRAM0	12 kB	0x2000 0000	Always
SRAM1	12 kB	0x2000 3000	Programmable by the user

1.3.3 Embedded ROM

The BlueNRG-LPS has a total of 7 kB of embedded ROM. This area is ST reserved and contains:

- The UART bootloader from which the CPU boots after each reset (first 6 kB of ROM memory)
- Some ST reserved values including the ADC trimming values (the last 1 kB of ROM memory)

1.3.4 Embedded OTP

The one-time-programmable (OTP) is a memory of 1 kB dedicated for user data. The OTP data cannot be erased.

The user can protect the OTP data area by writing the last word at address 0x1000 1BFC and by performing a system reset. This operation freezes the OTP memory from further unwanted write operations.

1.3.5 Memory protection unit (MPU)

The MPU is used to manage accesses to memory to prevent one task from accidentally corrupting the memory or resources used by any other active task. This memory area is organized into up to 8 protected areas. The protection area sizes are between 32 bytes and the whole 4 gigabytes of addressable memory.

The MPU is especially helpful for applications where some critical or certified code has to be protected against the misbehavior of other tasks. It is usually managed by an RTOS (real-time operating system). If a program accesses a memory location that is prohibited by the MPU, the RTOS can detect it and take action. In an RTOS environment, the kernel can dynamically update the MPU area settings, based on the process to be executed. The MPU is optional and can be bypassed for applications that do not need it.

1.4 Security and safety

The BlueNRG-LPS contains many security blocks for the BLE and the host application.

It includes:

- Flash read/write protection over accidental and intentional actions
- As protection against potential hacker attacks, the SWD access can be disabled
- Secure bootloader (refer to the dedicated application note AN5471)
- Customer storage of the BLE keys
- True random number generator (RNG)
- Public key accelerator (PKA) including:
 - Modular arithmetic including exponentiation with maximum modulo size of 3136 bits
 - Elliptic curves over prime field scalar multiplication, ECDSA signature, ECDSA verification with maximum modulo size of 521 bits
- Cyclic redundancy check calculation unit (CRC)

1.5 RF subsystem

The BlueNRG-LPS embeds an ultra-low power radio, compliant with Bluetooth® Low Energy (BLE) specification. The BLE features 1 Mbps and 2 Mbps transfer rates as well as long range options (125 kbps, 500 kbps), supports multiple roles simultaneously acting at the same time as Bluetooth® Low Energy sensor and hub device.

The BLE protocol stack is implemented by an efficient system partitioned as follows:

- Hardware part: BlueCore handling time critical and time consuming BLE protocol parts
- Firmware part: Arm® Cortex®-M0+ core handling non time critical BLE protocol parts

1.5.1 RF front-end block diagram

The RF front end is based on a direct modulation of the carrier in TX, and uses a low IF architecture in RX mode.

Thanks to an internal transformer with RF pins, the circuit directly interfaces the antenna (single ended connection, impedance close to 50 Ω). The natural band pass behavior of the internal transformer simplifies outside circuitry aimed at harmonic filtering and out of band interferer rejection.

In transmit mode, the maximum output power is user selectable through the programmable LDO voltage of the power amplifier. A linearized, smoothed analog control offers a clean power ramp-up.

In receive mode the circuit can be used in standard high performance or in reduced power consumption (user programmable). The automatic gain control (AGC) is able to reduce the chain gain at both RF and IF locations, for an optimized interferer rejection. Thanks to the use of complex filtering and highly accurate I/Q architecture, high sensitivity, and excellent linearity can be achieved.

Figure 3. BlueNRG-LPS RF block diagram

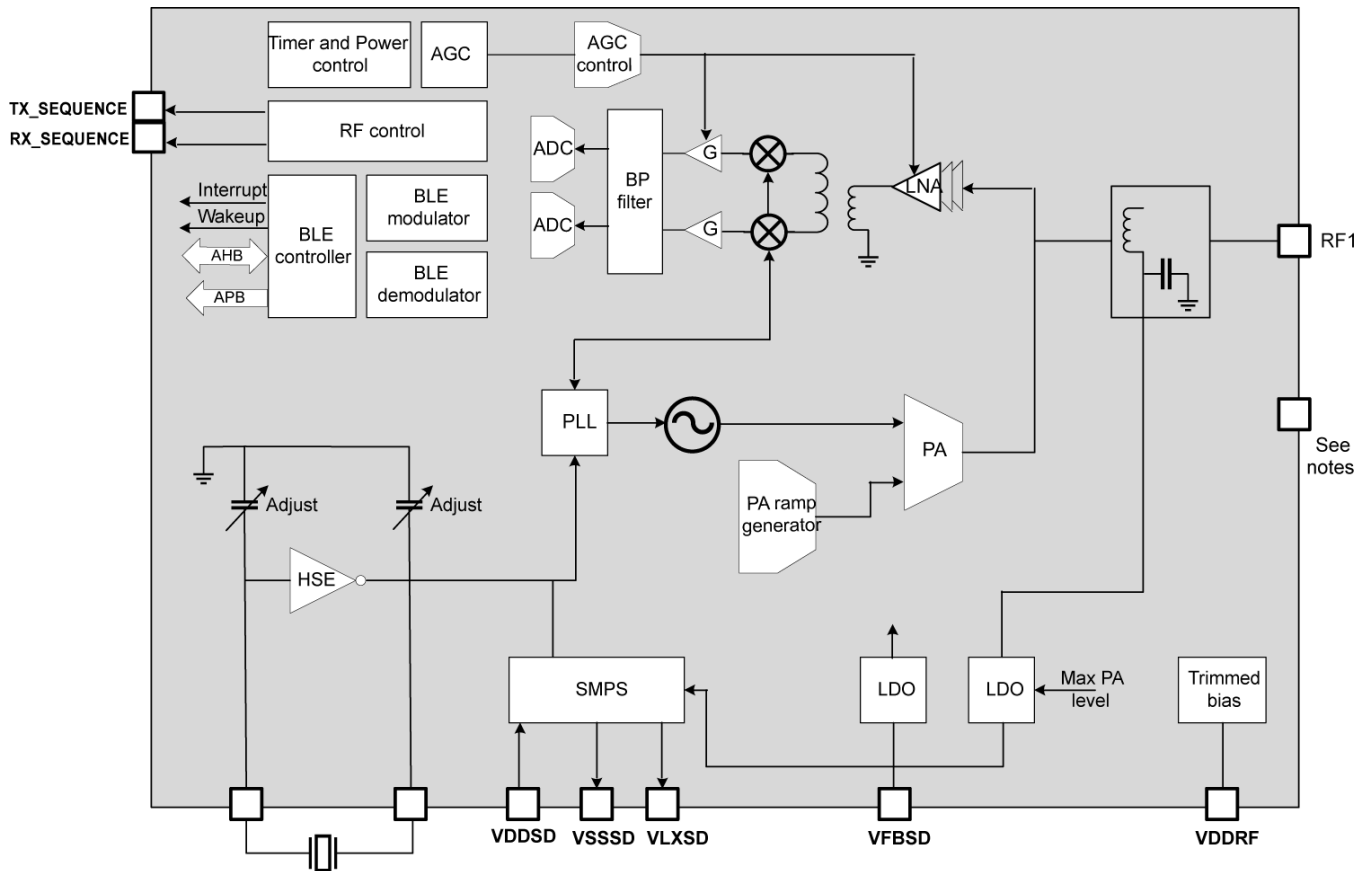

Note: QFN32: VSS through exposed pad, and VSSRF pins must be connected to ground plane.
CSP36: VSSRF pins must be connected to ground plane.

1.6 Power supply management

1.6.1 SMPS step-down regulator

The device integrates a step-down converter to improve low power performance when the VDD voltage is high enough. The SMPS output voltage can be programmed from 1.2 V to 1.90 V. It is internally clocked at 4 MHz or 8 MHz.

The device can be operated without the SMPS by just wiring its output to VDD. This is the case for applications where the voltage is low, or where the power consumption is not critical.

Except for the configuration SMPS OFF, an L/C BOM must be present on the board and connected to the VFBSD pad.

Figure 4. Power supply configuration

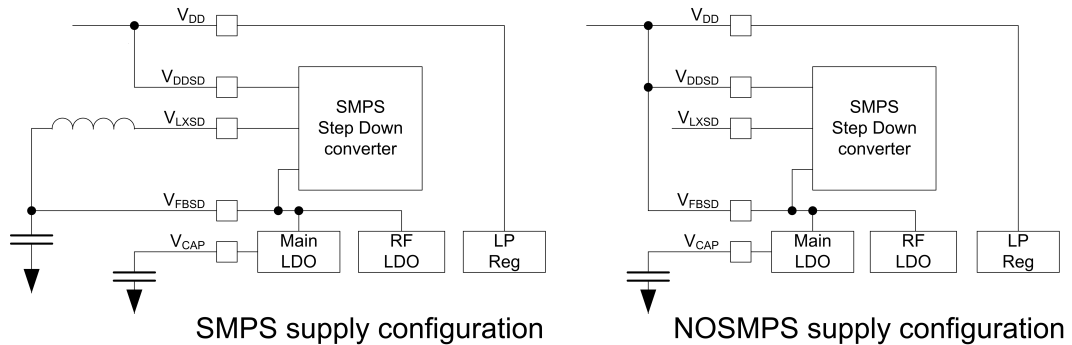

1.6.2 Power supply schemes

The BlueNRG-LPS embeds three power domains:

- VDD33 (VDDIO or VDD):
 - the voltage range is between 1.7 V and 3.6 V
 - it supplies a part of the I/O ring, the embedded regulators and the system analog IPs as power management block and embedded oscillators
- VDD12o:
 - always-on digital power domain
 - this domain is generally supplied at 1.2 V during active phase of the device
 - this domain is supplied at 1.0 V during low power mode (DEEPSTOP)
- VDD12i:
 - interruptible digital power domain
 - this domain is generally supplied at 1.2 V during active phase of the device
 - this domain is shut down during low power mode (DEEPSTOP)

Figure 5. Power supply domain overview

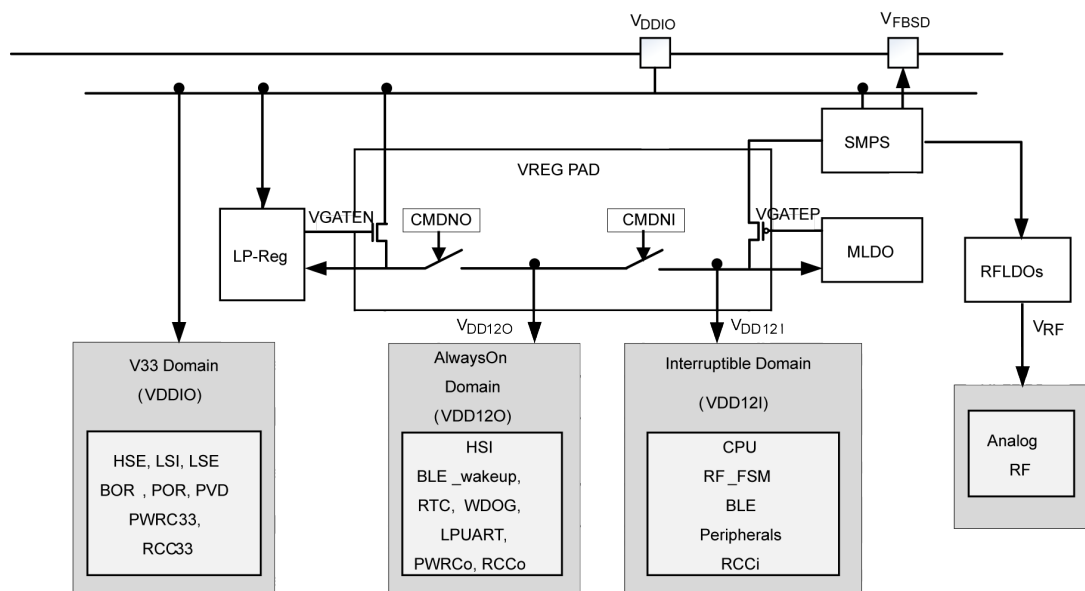

1.6.3 Linear voltage regulators

The digital power supplies are provided by different regulators:

- The main LDO (MLDO):
 - it provides 1.2 V from a 1.4-3.3 V input voltage
 - it supplies both VDD12i and VDD12o when the device is active
 - it is disabled during the low power mode (DEEPSTOP)
 - Low power LDO (LPREG):
 - it stays enabled during both active and low power phases
 - it provides 1.0 V voltage
 - it is not connected to the digital domain when the device is active
 - it is connected to the VDD12o domain during low power mode (DEEPSTOP)
 - A dedicated LDO (RFLDO) to provide a 1.2 V to the analog RF block
- An embedded SMPS step-down converter is available (inserted between the external power and the LDOs).

1.6.4 Power supply supervisor

The BlueNRG-LPS device embeds several power voltage monitoring:

- Power-on-reset (POR): during the power-on, the device remains in reset mode if VDDIO is below a VPOR threshold (typically 1.65 V)
- Power-down-reset (PDR): during power-down, the PDR puts the device under reset when the supply voltage (VDD) drops below the VPDR threshold (around 20 mV below VPOR). The PDR feature is always enabled
- Power voltage detector (PVD): can be used to monitor the VDDIO (against a programmed threshold) or an external analog input signal. When the feature is enabled and the PVD measures a voltage below the comparator, an interrupt is generated (if unmasked)

1.7 Operating modes

Several operating modes are defined for the BlueNRG-LPS:

- RUN mode
- DEEPSTOP mode
- SHUTDOWN mode

Table 2. Relationship between the low power modes and functional blocks

Mode	SHUTDOWN	DEEPSTOP	IDLE	RUN
CPU	OFF	OFF	OFF	ON
Flash	OFF	OFF	ON	ON
RAM	OFF	ON/OFF granularity 12 kB	ON/OFF	ON/OFF
Radio	OFF	OFF	ON/OFF	ON/OFF
Supply system	OFF	OFF	ON (DC-DC ON/OFF)	ON (DC-DC ON/OFF)
Register retention	OFF	ON	ON	ON
HS clock	OFF	OFF	ON	ON
LS clock	OFF	ON/OFF	ON	ON
Peripherals	OFF	OFF	ON/OFF	ON/OFF
Wake-on RTC	OFF	ON/OFF	ON/OFF	NA
Wake on LPUART	OFF	ON/OFF	ON/OFF	NA
Wake on IWDG	OFF	ON/OFF	ON/OFF	NA
Wake-on GPIOs	OFF	ON/OFF	ON/OFF	NA
Wake-on reset pin	ON	ON	ON	NA
GPIOs configuration retention	PWRC pull-up/pull-down only	ON	ON	ON

1.7.1 RUN mode

In RUN mode the BlueNRG-LPS is fully operational:

- All interfaces are active
- The internal power supplies are active
- The system clock and the bus clock are running
- The CPU core and the radio can be used

The power consumption may be reduced by gating the clock of the unused peripherals.

1.7.2 DEEPSTOP mode

DEEPSTOP is the only low-power mode of the BlueNRG-LPS allowing the restart from a saved context environment and the application at wake-up to go on running.

The conditions to enter DEEPSTOP mode are:

- The radio is sleeping (no radio activity)
- The CPU is sleeping (WFI with SLEEPDEEP bit activated)
- No unmasked wake-up sources are active
- The low-power mode selection (LPMS) bit of the power controller unit is 0 (default)
- The GPIO Retention Mode Selection (GPIORET) bit of the Power Controller unit must be set

In DEEPSTOP mode:

- The system and the bus clocks are stopped
- Only the essential digital power domain is ON and supplied at 1.0 V
- The bank RAM0 is kept in retention
- The bank RAM1 can be in retention or not, depending on the software configuration
- The I/Os pull-up and pull-down can be controlled during DEEPSTOP mode, depending on the software configuration
- The low speed clock can be running or stopped, depending on the software configuration:
 - ON or OFF
 - Sourced by LSE or by LSI
- The RTC, IWDG and LPUART stay active, if enabled and the low speed clock is ON
- The radio wake-up block, including its timer, stay active (if enabled and the low speed clock is ON)
- Up to 20 GPIOs retaining their configuration:
 - I/Os retain the RUN mode configuration while in DEEPSTOP mode
- Up to 20 I/Os are able to be in output driving:
 - A static low or high level
- Some I/Os are able to be in output driving:
 - The low speed clock (on PA10)
 - The RTC output (on PA8)

Possible wake-up sources are:

- The radio block is able to generate two events to wake up the system through its embedded wake-up timer running on low speed clock:
 - Radio wake-up time is reached
 - CPU host wake-up time is reached
- The RTC can generate a wake-up event
- The IWDG can generate a reset event
- The LPUART is able to generate a wake-up event
- All GPIOs are able to wake up the system

At wake-up, all the hardware resources located in the digital power domain that are OFF during the DEEPSTOP mode, are reset. The CPU reboots. The wake-up reason is visible in the register of the power controller.

1.7.3 SHUTDOWN mode

The SHUTDOWN mode is the least power consuming mode.

The conditions to enter SHUTDOWN mode are the same conditions needed to enter DEEPSLEEP mode except that the LPMS bit of the power controller unit is 1.

In SHUTDOWN mode, the BlueNRG-LPS is in ultra-low power consumption: all voltage regulators, clocks and the RF interface are not powered. The BlueNRG-LPS can enter shutdown mode by internal software sequence. The only way to exit shutdown mode is by asserting and deasserting the RSTN pin.

In SHUTDOWN mode:

- The system is powered down as both the regulators are OFF
- The VDDIO power domain is ON
- All the clocks are OFF, LSI and LSE are OFF
- The I/Os pull-up and pull-down can be controlled during SHUTDOWN mode, depending on the software configuration
- The only wake-up source is a low pulse on the RSTN pin

The exit from SHUTDOWN is similar to a POR startup. The PDR feature can be enabled or disabled during SHUTDOWN.

1.8 Reset management

The BlueNRG-LPS offers two different resets:

- The PORESETn: this reset is provided by the low power management unit (LPMU) analog block and corresponds to a POR or PDR root cause. It is linked to power voltage ramp-up or ramp-down. This reset impacts all resources of the BlueNRG-LPS. The exit from SHUTDOWN mode is equivalent to a POR and thus generates a PORESETn. The PORESETn signal is active when the power supply of the device is below a threshold value or when the regulator does not provide the target voltage.
- The PADRESETn (system reset): this reset is built through several sources:
 - PORESETn
 - Reset due to the watchdog
The BlueNRG-LPS device embeds a watchdog timer, which may be used to recover from software crashes
 - Reset due to CPU Lockup
The Cortex®-M0+ generates a lockup to indicate the core is in the lock-up state resulting from an unrecoverable exception. The lock-up reset is masked if a debugger is connected to the Cortex®-M0+
 - Software system reset
The system reset request is generated by the debug circuitry of the Cortex®-M0+. The debugger sets the SYSRESETREQ bit of the application interrupt and reset control register (AIRCR). This system reset request through the AIRCR can also be done by the embedded software (into the hardfault handler for instance)
 - Reset from the RSTN external pin
The RSTN pin toggles to inform that a reset has occurred

This PADRESETn resets all resources of the BlueNRG-LPS, except:

- Debug features
- Flash controller key management
- RTC timer
- Power controller unit
- Part of the RCC registers

The pulse generator guarantees a minimum reset pulse duration of 20 μ s for each internal reset source. In case of reset from the RSTN external pad, the reset pulse is generated when the pad is asserted low.

1.9 Clock management

Three different clock sources may be used to drive the system clock of the BlueNRG-LPS:

- HSI: high speed internal 64 MHz RC oscillator
- PLL64M: 64 MHz PLL clock
- HSE: high speed 32 MHz external crystal

The BlueNRG-LPS also has a low speed clock tree used by some timers in the radio, RTC, IWDG and LPUART.

Three different clock sources can be used for this low speed clock tree:

- Low speed internal (LSI): low speed and low drift internal RC with a fixed frequency between 24 kHz and 49 kHz depending on the sample
- Low speed external (LSE) from:
 - An external crystal 32.768 kHz
 - A single-ended 32.738 kHz input signal
- A 32 kHz clock derived from dividing HSI or HSE. In this case, the slow clock is not available in DEEPSTOP low-power mode

By default, after a system reset, all low speed sources are OFF.

Both the activation and the selection of the slow clock are relevant during DEEPSTOP mode and at wakeup as slow clock generates a clock for the timers involved in wake-up event generation.

The HSI and the PLL64M clocks are provided by the same analog block called RC64MPLL. The 64 MHz clock output by this block can be:

- A non-accurate clock when no external XO provides an input clock to this block (HSI)
- An accurate clock when the external XO provides the 32 MHz and once its internal PLL is locked (PLL64M)

After reset, the CLK_SYS is divided by four to provide 16 MHz to the whole system (CPU, DMA, memories and peripherals).

- LPUART: always uses a 16 MHz clock or LSE to have a fixed reference clock for baud rate management. The goal is to allow the CPU to boost or slow down the system clock (depending on on-going activities) without impacting a potential on-going serial interface transfer on external I/Os.
- SPI: when using the I2S mode, the baud rate is managed through the always 16 MHz or always 32 MHz clock or system clock (CLK_SYS) to reach higher baud rates. When running in other modes than the I2S, the baud rate is managed by the system clock. This implies its baud rate is impacted by dynamic system clock frequency changes.
- RNG: in parallel with the system clock, the RNG uses an always 16 MHz clock to generate at a constant frequency the random number whatever the system clock frequency
- Flash controller: in parallel with the system clock, the Flash controller uses an always 16 MHz clock to generate specific delays required by the Flash memory during programming and erase operations for example
- PKA: in parallel with the system clock, the PKA uses the system clock frequency
- Radio: it does not directly use the system clock for its APB/AHB interfaces, but the system clock with a potential divider (1 or 2 or 4). In parallel, the radio uses an always 16 MHz and an always 32 MHz for modulator, demodulator and to have a fixed reference clock to manage specific delays
- ADC: in parallel with the system clock, ADC uses a 64 MHz prescaled clock running at 16 MHz

1.10 Boot mode

Following CPU boot, the application software can modify the memory map at address 0x0000 0000. This modification is performed by programming the REMAP bit in the Flash controller.

The following memory can be remapped:

- Main Flash memory
- SRAM0 memory

1.11 Embedded UART bootloader

The BlueNRG-LPS has a pre-programmed bootloader supporting UART protocol with automatic baud rate detection. The main features of the embedded bootloader are:

- Auto baud rate detection up to 1 Mbps
- Flash mass erase, section erase
- Flash programming
- Flash readout protection enable/disable

The pre-programmed bootloader is an application, which is stored in the BlueNRG-LPS internal ROM at manufacturing time by STMicroelectronics. This application allows upgrading the device Flash with a user application using a serial communication channel (UART).

Bootloader is activated by hardware by forcing PA10 high during hardware reset, otherwise, application residing in Flash is launched.

Note: Bootloader protocol is described in a separate application note (the UART bootloader protocol, AN5471)

1.12 General purpose inputs/outputs (GPIO)

Each of the GPIO pins can be configured by software as output (push-pull or open-drain), as input (with or without pull-up or pull-down) or as peripheral alternate function. Most of the GPIO pins are shared with digital or analog alternate functions. Fast I/O toggling can be achieved thanks to their mapping on the AHB0 bus.

The I/Os alternate function configuration can be locked if needed following a specific sequence in order to avoid spurious writing to the I/Os registers.

1.13 Direct memory access (DMA)

The DMA is used in order to provide high-speed data transfer between peripherals and memory as well as memory-to-memory. Data can be quickly moved by DMA without any CPU actions. In this manner, CPU resources are free for other operations.

The DMA controller has eight channels in total. Each has an arbiter to handle the priority among DMA requests.

DMA main features are:

- Eight independently configurable channels (requests)

- Each of the eight channels is connected to dedicated hardware DMA requests, software trigger is also supported on each channel. This configuration is done by software
- Priorities among requests from channels of DMA are software programmable (four levels consisting of very high, high, medium, low) or hardware in case of equality (request 1 has priority over request 2, and so on)
- Independent source and destination transfer size (byte, half word, word), emulating packing and unpacking. Source/destination addresses must be aligned on the data size
- Support for circular buffer management
- Three event flags (DMA half transfer, DMA transfer complete and DMA transfer error) logically ORed together in a single interrupt request for each channel
- Memory-to-memory transfer (RAM only)
- Peripheral-to-memory and memory-to-peripheral, and peripheral-to-peripheral transfers
- Access to SRAMs, APB0 and APB1 peripherals as source and destination
- Programmable number of data to be transferred: up to 65536

1.14 Nested vectored interrupt controller (NVIC)

The interrupts are handled by the Cortex®-M0+ nested vector interrupt controller (NVIC). NVIC controls specific Cortex®-M0+ interrupts as well as the BlueNRG-LPS peripheral interrupts.

The NVIC benefits are the following:

- Nested vectored interrupt controller that is an integral part of the ARM® Cortex®-M0+
- Tightly coupled interrupt controller provides low interrupt latency
- Control system exceptions and peripheral interrupts
- NVIC supports 32 vectored interrupts
- Four programmable interrupt priority levels with hardware priority level masking
- Software interrupt generation using the ARM® exceptions SVCall and PendSV
- Support for NMI
- ARM® Cortex® M0+ vector table offset register VTOR implemented

NVIC hardware block provides flexible interrupt management features with minimal interrupt latency.

1.15 Analog digital converter (ADC)

The BlueNRG-LPS embeds a 12-bit ADC. The ADC consists of a 12-bit successive approximation analog-to-digital converter (SAR) with 2 x 8 multiplexed channels allowing measurements of up to eight external sources and up to two internal sources.

The ADC main features are:

- Conversion frequency is up to 1 Msps
- Three input voltage ranges are supported (0 - 1.2 V, 0 - 2.4 V, 0 - 3.6 V)
- Up to eight analog single-ended channels or four analog differential inputs or a mix of both
- Temperature sensor conversion
- Battery level conversion up to 3.6 V
- ADC continuous or single mode conversion is possible
- ADC down-sampler for multi-purpose applications to improve analog performance while off-loading the CPU (ratio adjustable from 1 to 128)
- A watchdog feature to inform when data is outside thresholds
- DMA capability
- Interrupt sources with flags.

1.15.1 Temperature sensor

The temperature sensor (TS) generates a voltage that varies linearly with temperature. The temperature sensor is internally connected to the ADC input channel, which is used to convert the sensor output voltage into a digital value.

To improve the accuracy of the temperature sensor measurement, each device is individually factory-calibrated by ST. The temperature sensor factory calibration data are stored by ST in the system memory area, accessible in read-only mode.

1.16 True random number generator (RNG)

RNG is a random number generator based on a continuous analog noise that provides a 16-bit value to the host when read. The minimum period is 1.25 us, corresponding to 20 RNG clock cycles between two consecutive random number.

1.17 Timers and watchdog

The BlueNRG-LPS includes three general-purpose timers, one watchdog timer and a SysTick timer.

1.17.1 General-purpose timers (TIM2, TIM16, TIM17)

There are up to three general-purpose timers embedded in the BlueNRG-LPS.

Each general-purpose timer can be used to generate PWM outputs, or act as a simple time base.

- TIM2
 - Full-featured general-purpose timer
 - Features four independent channels for input capture/output compare, PWM or one-pulse mode output
 - Independent DMA request generation, support of quadrature encoders
- TIM16 and TIM17
 - General-purpose timers with mid-range features:
 - 16-bit auto-reload upcounters and 16-bit prescalers
 - 1 channel and 1 complementary channel
 - All channels can be used for input capture/output compare, PWM or one-pulse mode output
 - The timers have independent DMA request generation
 - The timers are internally connected to generate an infrared interface (IRTIM) for remote control

1.17.2 Independent watchdog (IWDG)

The independent watchdog is based on a 12-bit downcounter and 8-bit prescaler. It is clocked from the LS clock and it can operate in DEEPSLEEP mode. It can also be used as a watchdog to reset the device when a problem occurs.

1.17.3 SysTick timer

This timer is dedicated to real-time operating systems, but could also be used as a standard down counter. It features:

- A 24-bit down counter
- Autoreload capability
- Maskable system interrupt generation when the counter reaches 0

1.18 Real-time clock (RTC)

The RTC is an independent BCD timer/counter. The RTC provides a time of day/clock/calendar with programmable alarm interrupt. RTC includes also a periodic programmable wake-up flag with interrupt capability. The RTC provides an automatic wake-up to manage all low power modes.

Two 32-bit registers contain seconds, minutes, hours (12- or 24-hour format), day (day of week), date (day of month), month, and year, expressed in binary coded decimal format (BCD). The sub-second value is also available in binary format. Compensations for 28-, 29- (leap year), 30-, and 31-day months are performed automatically. Daylight saving time compensation can also be performed. Additional 32-bit registers contain the programmable alarm sub seconds, seconds, minutes, hours, day, and date.

A digital calibration circuit with 0.95 ppm resolution is available to compensate for quartz crystal inaccuracy. After power-on reset, all RTC registers are protected against possible parasitic write accesses. As long as the supply voltage remains in the operating range, the RTC never stops, regardless of the device status (RUN mode, low power mode or under system reset). The RTC counter does not freeze when CPU is halted by a debugger.

1.19 Inter-integrated circuit interface (I²C)

The BlueNRG-LPS embeds one I²Cs. The I²C bus interface handles communications between the microcontroller and the serial I²C bus. It controls all I²C bus-specific sequencing, protocol, arbitration and timing.

The I²C peripheral supports:

- I²C bus specification and user manual rev. 5 compatibilities:
 - Slave and master modes
 - Multimaster capability
 - Standard-mode (Sm), with a bitrate up to 100 kbit/s
 - Fast-mode (Fm), with a bitrate up to 400 kbit/s
 - Fast-mode Plus (fm+), with a bitrate up to 1 Mbit/s and 20 mA output driver I/Os
 - 7-bit and 10-bit addressing mode
 - Multiple 7-bit slave addresses (2 addresses, 1 with configurable mask)
 - All 7-bit address acknowledge mode
 - General call
 - Programmable setup and hold times
 - Easy to use event management
 - Optional clock stretching
 - Software reset
- System management Bus (SMBus) specification rev 2.0 compatibility:
 - Hardware PEC (Packet Error Checking) generation and verification with ACK control
 - Address resolution protocol (ARP) support
 - Host and device support
 - SMBus alert
 - Timeouts and idle condition detection
- Power system management protocol (PMBus™) specification rev 1.1 compatibility
- Independent clock: a choice of independent clock sources allowing the I²C communication speed to be independent from the PCLK reprogramming
- Programmable analog and digital noise filters
- 1-byte buffer with DMA capability

1.20 Universal synchronous/asynchronous receiver transmitter (USART)

USART offers flexible full-duplex data exchange with external equipment requiring an industry standard NRZ asynchronous serial data format. USART is able to communicate with a speed up to 2 Mbit/s. Furthermore, USART is able to detect and automatically set its own baud rate, based on the reception of a single character.

The USART peripheral supports:

- Synchronous one-way communication
- Half-duplex single wire communication
- Local interconnection network (LIN) master/slave capability
- Smart card mode, ISO 7816 compliant protocol
- IrDA (infrared data association) SIR ENDEC specifications
- Modem operations (CTS/RTS)
- RS485 driver enable
- Multiprocessor communications
- SPI-like communication capability

High speed data communication is possible by using DMA (direct memory access) for multibuffer configuration.

1.21 LPUART

The device embeds one low-power UART, enabling asynchronous serial communication with minimum power consumption. The LPUART supports half duplex single wire communication and modem operations (CTS/RTS), allowing multiprocessor communication.

The LPUART has a clock domain independent from the CPU clock, and can wake up the system from DEEPSLEEP mode using baud rates up to 9600 baud. The wake-up events from Stop mode are programmable and can be:

- Start bit detection
- Any received data frame
- A specific programmed data frame

Only a 32.768 kHz clock (LSE) is needed to allow LPUART communication up to 9600 baud. Therefore, even in DEEPSTOP mode, the LPUART can wait for an incoming frame while having an extremely low energy consumption. Higher speed clock can be used to reach higher baud rates in RUN mode.

The LPUART interfaces can be served by the DMA controller.

1.22 Serial peripheral interface (SPI)

The BlueNRG-LPS has one SPI interface (SPI3) allowing communication up to 32 Mbit/s in both master and slave modes. The SPI peripheral supports:

- Master or slave operation
- Multimaster support
- Full-duplex synchronous transfers on three lines
- Half-duplex synchronous transfer on two lines (with bidirectional data line)
- Simplex synchronous transfers on two lines (with unidirectional data line)
- Serial communication with external devices
- NSS management by hardware or software for both master and slave: dynamic change of master/slave operations
- SPI Motorola support
- SPI TI mode support
- Hardware CRC feature for reliable communication

All SPI interfaces can be served by the DMA controller.

1.23 Inter-IC sound (I2S)

The BlueNRG-LPS SPI interface SPI3 supports the I2S protocol. The I2S interface can operate in slave or master mode with half-duplex communication. It can address four different audio standards:

- Philips I2S standard
- MSB-justified standards (left-justified)
- LSB-justified standards (right-justified)
- PCM standard.

The I2S interfaces DMA capability for transmission and reception.

1.24 Serial wire debug port

The BlueNRG-LPS embeds an ARM SWD interface that allows interactive debugging and programming of the device. The interface is composed of only two pins: SWDIO and SWCLK. The enhanced debugging features for developers allow up to 4 breakpoints and up to 2 watchpoints.

1.25 TX and RX event alert

The BlueNRG-LPS is provided with the TX_SEQUENCE and RX_SEQUENCE signals which alert, respectively, transmission and reception activities.

A signal can be enabled for TX and RX on two pins, through alternate functions:

- TX_SEQUENCE is available on PA10 (AF2) or PB14 (AF1).
- RX_SEQUENCE is available on PA8 (AF2) or PA11 (AF2).

The signal is high when radio is in TX (or RX), low otherwise.

The signals can be used to control external antenna switching and support coexistence with other wireless technologies.

Note:

The RF_ACTIVITY signal is used to notify if there is an ongoing RF operation (either TX or RX). It is a logical OR between the RX_SEQUENCE and TX_SEQUENCE. This signal can be used to enable an antenna switch component when achieving antenna switching during AoA or AoD operation.

1.26 Direction finding

The BlueNRG-LPS Bluetooth radio controller supports the angle of arrival (AoA) and angle of departure (AoD) features by managing:

- the constant tone extension (CTE) inside a packet
- the antenna switching mechanism for both AoA and AoD.

The antenna switching mechanism provides a 7-bit antenna identifier ANTENNA_ID[6:0] indicating the antenna number to be used.

In a AoD transmitter or in a AoA receiver, the radio needs to switch antenna during the CTE field of the packet. For this purpose, the ANTENNA_ID signal can be enabled on some I/Os, by programming them in the associated alternate function. This signal needs to be provided to an external antenna switching circuit, since ANTENNA_ID[0] is the least significant bit and ANTENNA_ID[6] the most significant bit of the antenna identifier to be used.

2 Pinouts and pin description

The BlueNRG-LPS comes in two package versions: WLCSP36 offering 20 GPIOs and QFN32 offering 20 GPIOs.

Figure 7. Pinout top view (QFN32 package)

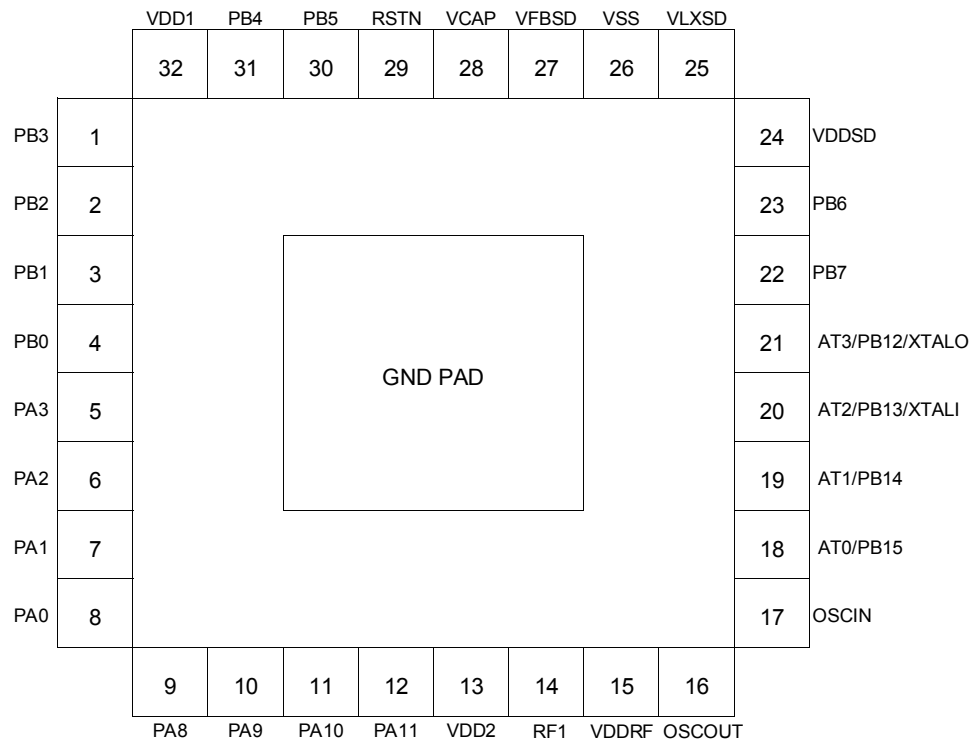

Figure 8. Pinout bump side view (WLCSP36 package)

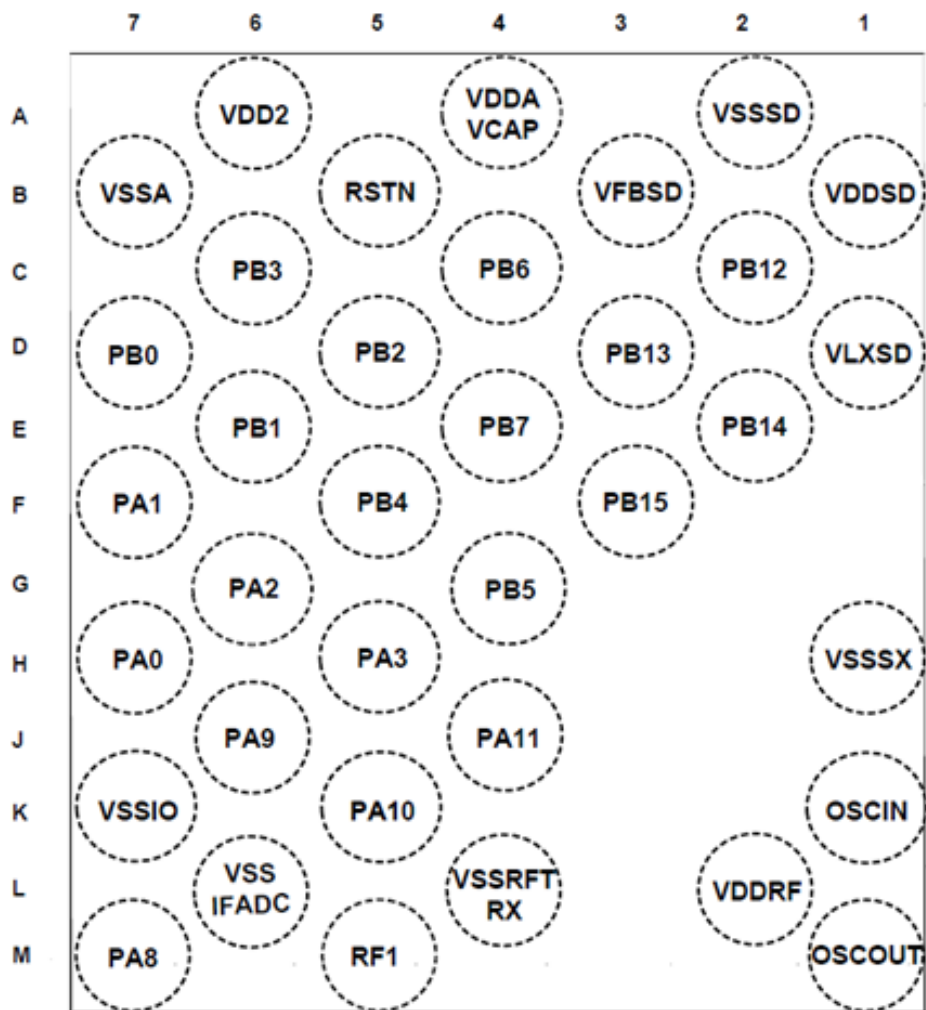

Table 3. Pins description

Pin number		Pin name (function after reset)	Pin type	I/O structure	Alternate functions	Additional functions
QFN32	WLCSP36					
1	C6	PB3	I/O	FT_a	USART_CTS, LPUART_TX, SPI3_SCK, TIM2_CH4, TIM17_CH1, ANTENNA_ID[3], I2S3_SCK	ADC_VINP0, wakeup
2	D5	PB2	I/O	FT_a	USART_RTS_DE, TIM2_CH3, TIM16_BK	ADC_VINM0, wakeup
3	E6	PB1	I/O	FT_a	USART_CK, TIM2_ETR, TIM16_CH1N, ANTENNA_ID[1]	ADC_VINP1, wakeup
4	D7	PB0	I/O	FT_a	USART_RX, LPUART_RTS_DE, TIM16_CH1, ANTENNA_ID[0]	ADC_VINM1, wakeup
5	H5	PA3	I/O	FT_a	SWCLK, USART_RTS_DE, SPI3_SCK, TIM2_CH2, TIM16_CH1N, I2S3_SCK	ADC_VINP2, wakeup
6	G6	PA2	I/O	FT_a	SWDIO, USART_CK, SPI3_MCK, TIM2_CH1, TIM16_CH1, I2S3_MCK	ADC_VINM2, wakeup
7	F7	PA1	I/O	FT_f	I2C1_SDA, IR_OUT, USART_TX, TIM2_CH4	Wakeup
8	H7	PA0	I/O	FT_f	I2C1_SCL, USART_CTS, IR_OUT, TIM2_CH3	Wakeup
9	M7	PA8	I/O	FT	USART_RX, RX_SEQUENCE, SPI3_MISO, TIM2_CH3, TIM16BK, I2S3_MISO	Wakeup, RTC_OUT
10	J6	PA9	I/O	FT	USART_TX, RTC_OUT, SPI3_NSS, TIM2_CH4, TIM17_CH1, I2S3_WS	Wakeup
11	K5	PA10	I/O	FT	LPUART_CTS, TX_SEQUENCE, SPI3_MCK, TIM17_CH1N, I2S3_MCK	Wakeup, LCO
12	J4	PA11	I/O	FT	MCO, RX_SEQUENCE, SPI3_MOSI, TIM17_BK, I2S3_SD	Wakeup
13	A6	VDD2	S	-	-	1.7-3.6 battery voltage input
14	M5	RF1	I/O	RF	-	RF input/output. Impedance 50 Ω
15	L2	VDDRF	S	-	-	1.7-3.6 battery voltage input
16	M1	OSCOUT	I/O	FT_a	-	32 MHz crystal
17	K1	OSCIN	I/O	FT_a	-	32 MHz crystal
18	F3	PB15	I/O	FT_a	USART_RX	Wakeup
19	E2	PB14	I/O	FT_a	TX_SEQUENCE, I2C1_SDA, TIM2_ETR, MCO, USART_RX	PVD_IN, Wakeup
20	D3	PB13	I/O	FT_a	TIM2_CH4	SXTAL1, Wakeup
21	C2	PB12	I/O	FT_a	LPUART_CTS, LCO, TIM2_CH3	SXTAL0, Wakeup
22	E4	PB7	I/O	FT_f	USART_CTS, I2C1_SDA, LPUART_RX, TIM2_CH2, RF_ACTIVITY	Wakeup
23	C4	PB6	I/O	FT_f	I2C1_SCL, LPUART_TX, TIM2_CH1, TIM17_CH1, ANTENNA_ID[6]	Wakeup
24	B1	VDDSD	S	-	-	1.7-3.6 battery voltage input
25	D1	VLXSD	S	-	-	SMPS input/output

Pin number		Pin name (function after reset)	Pin type	I/O structure	Alternate functions	Additional functions
QFN32	WLCSP36					
26	A2	VSSSD	S	-	-	SMPS Ground
27	B3	VFBSD	S	-	-	SMPS output
28	A4	VDDA_VCAP	S	-	-	1.2 V digital core
29	B5	RSTN	I/O	RST		Reset pin
30	G4	PB5	I/O	FT_a	LPUART_RX, TIM2_CH2, TIM17_BK, ANTENNA_ID[5]	Wakeup, ADC_VINP3
31	F5	PB4	I/O	FT_a	LPUART_TX, TIM2_CH1, TIM17_CH1N, ANTENNA_ID[4]	Wakeup, ADC_VINM3
32	-	VDD1	S	-	-	1.7-3.6 battery voltage input
-	B7	VSSA	S	-	-	Ground analog ADC core
-	k7	VSSIO	S	-	-	Ground I/O
-	L6	VSSIFADC	S	-	-	Ground analog RF
-	H1	VSSSX	S	-	-	Ground analog RF
-	L4	VSSRFTRX	S	-	-	Ground analog RF
Exposed pad	-	GND	S	-	-	Ground

Table 4. Legend/abbreviations used in the pinout table

Name		Abbreviation	Definition
Pin name		Unless otherwise specified in brackets below, the pin name and the pin function during and after reset are the same as the actual pin name	
Pin type		S	Supply pin
		I	Input only pin
		I/O	Input / output pin
I/O structure		FT	5 V tolerant I/O
		TT	3.6 V tolerant I/O
		RF	RF I/O
		RST	Bidirectional reset pin with weak pull-up resistor
		Options for TT or FT I/Os	
		_f ⁽¹⁾ .	I/O, Fm+ capable
	_a ⁽²⁾ .	I/O, with analog switch function supplied by IO BOOSTER ⁽³⁾	
Notes		Unless otherwise specified by a note, all I/Os are set as analog inputs during and after reset	
Pin functions	Alternate functions	Functions selected through GPIOx_AFR registers	
	Additional functions	Functions directly selected/enabled through peripheral registers	

1. The related I/O structures in Table 3. Pins description are: FT_f

2. The related I/O structures in Table 3. Pins description are: FT_a

3. IO BOOSTER block allows the good behavior of those switches to be guaranteed when the VBAT goes below 2.7 V.

Table 5. Alternate function port A

Port	AF0	AF1	AF2	AF3	AF4	AF5	AF6	AF7	
	I2C1/ SYS_AF/ USART	IR/LPUART/USART	IR/RTC USART/RF	SPI3	TIM2	SYS_AF	TIM16/TIM17	SYS_AF	
Port A	PA0	I2C1_SCL	USART_CTS	IR_OUT	-	TIM2_CH3	-	-	-
	PA1	I2C1_SDA	IR_OUT	USART_TX	-	TIM2_CH4	-	-	-
	PA2	SWDIO	USART_CK	-	SPI3_MCKK / I2S3_MCK	TIM2_CH1	SWDIO	TIM16_CH1	SWDIO
	PA3	SWCLK	USART_RTS_DE	-	SPI3_SCK / I2S3_SCK	TIM2_CH2	SWCLK	TIM16_CH1N	SWCLK
	PA8	USART_RX	-	RX_SEQUENCE	SPI3_MISO / I2S3_MISO	TIM2_CH3	-	TIM16_BK	-
	PA9	USART_TX	-	RTC_OUT	SPI3_NSS / I2S3_WS	TIM2_CH4	-	TIM17_CH1	-
	PA10	-	LPUART_CTS	TX_SEQUENCE	SPI3_MCK / I2S3_MCK	-	-	TIM17_CH1N	-
	PA11	MCO	-	RX_SEQUENCE	SPI3_MOSI / I2S3_SD	-	-	TIM17_BK	-

Table 6. Alternate function port B

Port	AF0	AF1	AF2	AF3	AF4	AF5	AF6	AF7	
	I2C1/ USART/ LPUART	SYS_AF/ LPUART	LPUART/TIM2 TIM16/RIM17	TIM2/SYS_AF/ LPUART	TIM2	-	RF/USART	-	
Port B	PB0	USART_RX	LPUART_RTS_DE	TIM16_CH1	-	-	ANTENNA_ID[0]	-	
	PB1	USART_CK	-	TIM16_CH1N	TIM2_ETR	-	ANTENNA_ID[1]	-	
	PB2	USART_RTS_DE	-	TIM16_BK	TIM2_CH3	-	ANTENNA_ID[2]	-	
	PB3	USART_CTS	LPUART_TX	TIM17_CH1	TIM2_CH4	SPI3_SCK / I2S3_SCK	-	ANTENNA_ID[3]	-
	PB4	LPUART_TX	-	TIM17_CH1N	-	TIM2_CH1	-	ANTENNA_ID[4]	-
	PB5	LPUART_RX	-	TIM17_BK	-	TIM2_CH2	-	ANTENNA_ID[5]	-
	PB6	I2C1_SCL	-	TIM17_CH1	LPUART_TX	TIM2_CH1	-	ANTENNA_ID[6]	-
	PB7	I2C1_SDA	-	USART_CTS	LPUART_RX	TIM2_CH2	-	RF_ACTIVITY	-
	PB12	-	LCO	LPUART_CTS	-	TIM2_CH3	-	-	-
	PB13	-	-	-	-	TIM2_CH4	-	-	-
	PB14	I2C1_SMBA	TX_SEQUENCE	TIM2_ETR	MCO	-	-	USART_RX	-
	PB15	-	-	-	-	-	-	USART_TX	-

3 Memory mapping

Program memory, data memory and registers are organized within the same linear 4-Gbyte address space.

Figure 9. Memory map

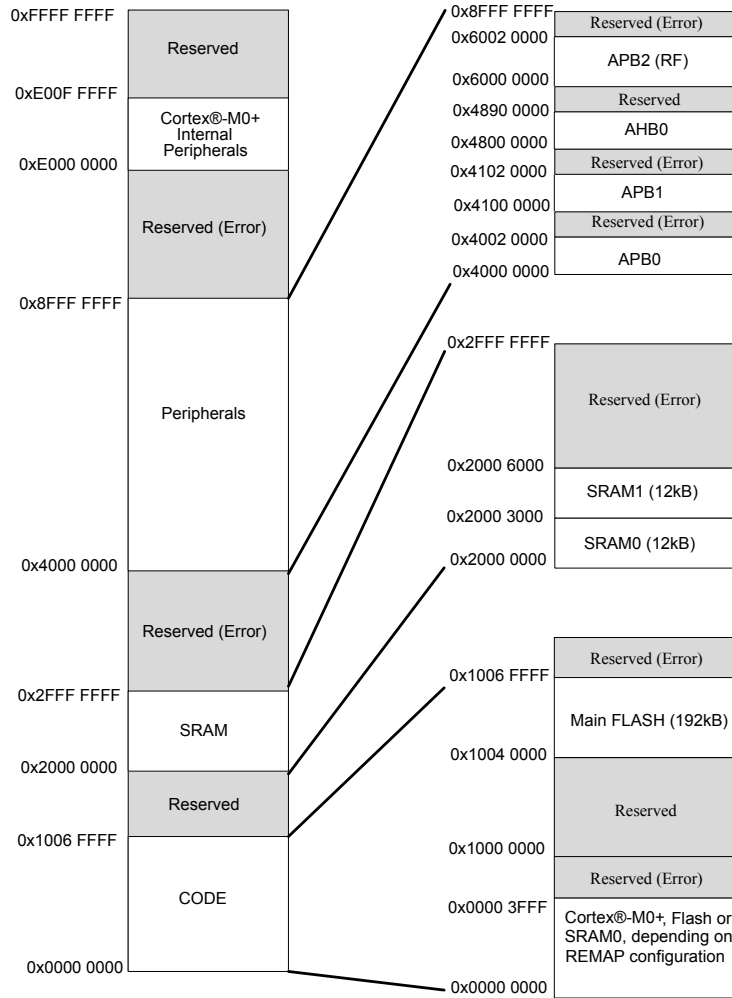

4 Application circuits

The schematics below are purely indicative.

Figure 10. Application circuit: DC-DC converter, WLCSP36 package

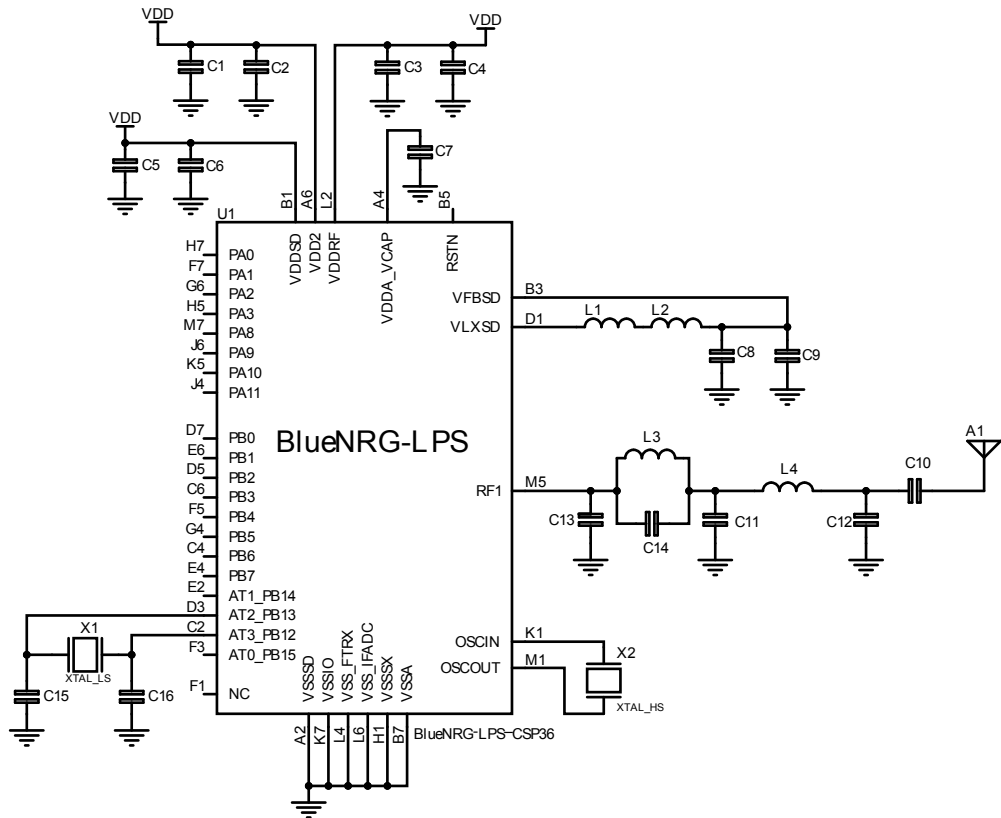

Figure 11. Application circuit: DC-DC converter, QFN32 package

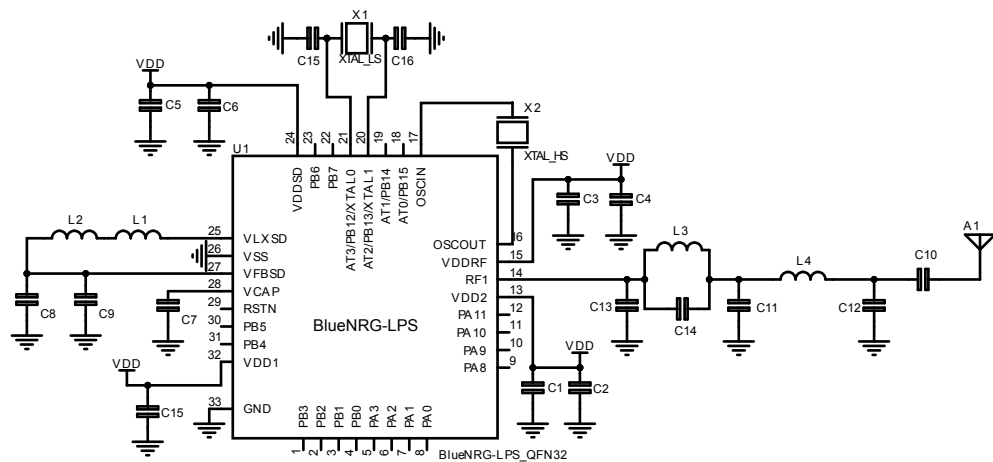

Table 7. Application circuit external components

Component	Description
C1	Decoupling capacitor
C2	Decoupling capacitor
C3	Decoupling capacitor
C4	Decoupling capacitor
C5	Decoupling capacitor
C6	Decoupling capacitor
C7	Main LDO capacitor
C8	DC-DC converter output capacitor
C9	DC-DC converter output capacitor
C10	DC block capacitor
C12	RF Matching capacitor
C13	RF Matching capacitor
C14	RF Matching capacitor
C15	32 kHz crystal loading capacitor
C16	32 kHz crystal loading capacitor
L1	DC-DC converter output inductor
L2	DC-DC converter noise filter
L3	RF matching inductor
L4	RF matching inductor
X1	Low speed crystal
X2	High speed crystal
U1	BlueNRG-LPS

Note: *In order to make the board DC-DC OFF, the inductance L1 must be removed and the supply voltage must be applied to the VFBS pin.*

5 Electrical characteristics

5.1 Parameter conditions

Unless otherwise specified, all voltages are referenced to ground (GND).

5.1.1 Minimum and maximum values

Unless otherwise specified, the minimum and maximum values are guaranteed in the following standard conditions:

- Ambient temperature is $T_A = 25\text{ °C}$
- Supply voltage is $V_{DD} = 3.3\text{ V}$
- System clock frequency is 32 MHz (clock source HSI)
- SMPS clock frequency is 4 MHz

Data based on characterization results, design simulation and/or technology characteristics are indicated in the table footnotes and are not tested in production. Based on characterization, the minimum and maximum values refer to sample tests and represent the mean value plus or minus three times the standard deviation (mean $\pm 3\sigma$).

5.1.2 Typical values

Unless otherwise specified, typical data are based on $T_A = 25\text{ °C}$, $V_{DD} = 3.3\text{ V}$. They are given only as design guidelines and are not tested.

Typical ADC accuracy values are determined by characterization of a batch of samples from a standard diffusion lot over the full temperature range, where 95% of the devices have an error less than or equal to the value indicated (mean $\pm 2\sigma$).

5.1.3 Typical curves

Unless otherwise specified, all typical curves are only given as design guidelines and are not tested.

5.1.4 Loading capacitor

The loading conditions used for pin parameter measurement are shown in the figure below.

Figure 12. Pin loading conditions

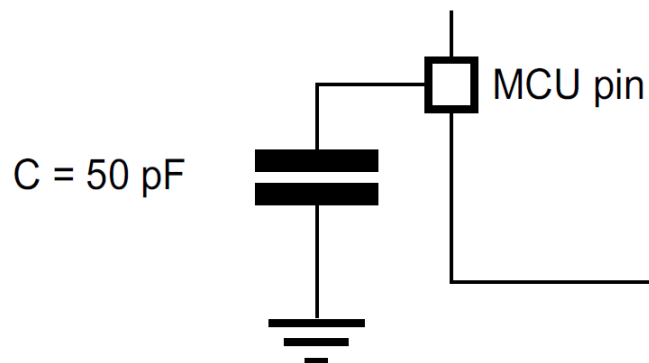

5.1.5 Pin input voltage

The input voltage measurement on a pin of the device is described in the figure below.

Figure 13. Pin input voltage

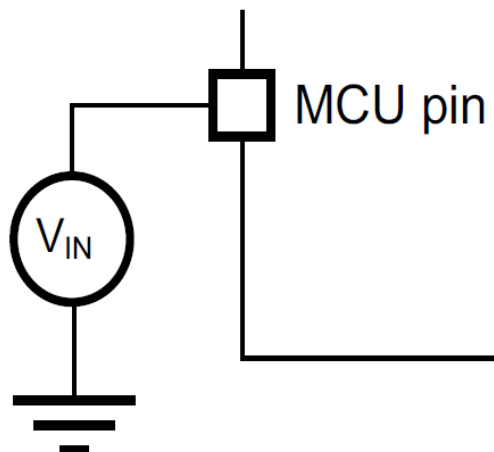

5.2 Absolute maximum ratings

Stresses above the absolute maximum ratings listed in the tables below, may cause permanent damage to the device. These are stress ratings only and functional operation of the device at these conditions is not implied. Exposure to maximum rating conditions for extended periods may affect device reliability.

Table 8. Voltage characteristics

Symbol	Ratings	Min.	Max.	Unit
VDD1, VDD2, VDD3, VDD4, VDDRF, VDDSD	DC-DC converter supply voltage input and output	-0.3	+3.9	V
VDDA_VCAP	DC voltage on linear voltage regulator	-0.3	+1.32	
FXTALOUT, FXTALIN	DC Voltage on HSE	-0.3	1.32	
PA0 to PA15, PB0 to PB15	DC voltage on digital input/output pins	-0.3	+3.9	
VLXSD, VFBSD	DC voltage on analog pins			
XTAL0/PB12, XTAL1/PB13	DC voltage on XTAL pins		+3.6	
RF1	DC voltage on RF pin	-0.3	+1.4	
$ \Delta V_{DD} $	Variations between different V_{DDX} power pins of the same domain		50	mV

Note: All the main power and ground pins must always be connected to the external power supply, in the permitted range.

Table 9. Current characteristics

Symbol	Ratings	Max.	Unit
ΣI_{VDD}	Total current into sum of all VDD power lines (source)	130	mA
$\Sigma I_{V_{GND}}$	Total current out of sum of all ground lines (sink)	130	
$I_{VDD(PIN)}$	Maximum current into each VDD power pin (source)	100	
$I_{V_{GND}(PIN)}$	Maximum current out of each ground pin (sink)	100	
$I_{IO(PIN)}$	Output current sunk by any I/O and control pin	20	
	Output current sourced by any I/O and control pin	20	
$\Sigma I_{IO(PIN)}$	Total output current sunk by sum of all I/Os and control pins	100	
	Total output current sourced by sum of all I/Os and control pins	100	
$\Sigma I_{INJ(PIN)} $	Total injected current (sum of all I/Os and control pins)	-5/0	

Table 10. Thermal characteristics

Symbol	Ratings	Value	Unit
T_{STG}	Storage temperature range	-40 to -125	°C
T_J	Maximum junction temperature	125	

5.3 Operating conditions

5.3.1 Summary of main performance

Table 11. Main performance SMPS ON

Symbol	Parameter	Test conditions	Typ. VDD = 1.8 V	Typ. VDD = 3.3 V	Unit
I_{CORE}	Core current consumption	SHUTDOWN	8	19	nA
		DEEPSTOP, no timer, wake-up GPIO, RAM0 retained	0.6	0.61	μA
		DEEPSTOP, no timer, wakeup GPIO, all RAM retained	0.63	0.64	
		DEEPSTOP (32 kHz LSI), RAM0 retained	1.06	1.12	
		DEEPSTOP (32 kHz LSI), all RAMs retained	1.09	1.15	
		DEEPSTOP (32 kHz LSE), RAM0 retained	0.85	0.96	
		DEEPSTOP (32 kHz LSE), all RAM retained	0.88	0.99	
		CPU in RUN (64 MHz). Dhrystone, clock source PLL64		2638	μA
		CPU in RUN (32 MHz). Dhrystone, clock source PLL64		2186	
		CPU in WFI (64 MHz), all peripherals off, clock source PLL64		1688	

Symbol	Parameter	Test conditions	Typ. VDD = 1.8 V	Typ. VDD = 3.3 V	Unit
I _{CORE}	Core current consumption	CPU in WFI (16 MHz), all peripherals off, clock source Direct HSE		1000	µA
		Radio RX at sensitivity level		3350	
		Radio TX 0 dBm output power		4300	
		Radio RX at sensitivity level with CPU in WFI (32MHz), clock source Direct HSE		4950	
		Radio TX 0 dBm output power with CPU in WFI (32MHz), clock source Direct HSE		5600	
I _{DYNAMIC}	Dynamic current	Computed value: (CPU 64 MHz Dhrystone - CPU 32 MHz Dhrystone) / 32		14	µA/MHz

Table 12. Main performance SMPS bypassed

Symbol	Parameter	Test conditions	Typ. VDD = 1.8 V	Typ. VDD = 3.3 V	Unit
I _{CORE}	Core current consumption	SHUTDOWN	8	19	nA
		DEEPSTOP, no timer, wake-up GPIO, RAM0 retained	0.6	0.61	μA
		DEEPSTOP, no timer, wake-up GPIO, all RAM retained	0.63	0.64	
		DEEPSTOP (32 kHz LSI), RAM0 retained	1.06	1.12	
		DEEPSTOP (32 kHz LSI), all RAMs retained	1.09	1.15	
		DEEPSTOP (32 kHz LSE), RAM0 retained	0.85	0.96	
		DEEPSTOP (32 kHz LSE), all RAM retained	0.88	0.99	
		CPU in RUN (64 MHz). Dhrystone, clock source PLL64		4450	
		CPU in WFI (64 MHz), all peripherals off, clock source PLL64		2313	
		CPU in WFI (16 MHz), all peripherals off, clock source Direct HSE		700	
		Radio RX at sensitivity level		6700	
		Radio TX 0 dBm output power		8900	
		Radio RX at sensitivity level with CPU in WFI (32MHz), clock source Direct HSE		9200	
		Radio TX 0 dBm output power with CPU in WFI (32MHz), clock source Direct HSE		11000	

Table 13. Peripheral current consumption at VDD = 3.3 V, system clock (CLK_SYS), SMPS on

Parameter	Test conditions	Typ.	Unit
ADC		39	μA
DMA		37	
GPIOA		2	
GPIOB		2	
I2C1		38	
IWDG		9	
LPUART		53	
PKA		25	
RNG		88	
RTC		12	
SPI3/I2S3		46	
Systick		10	
TIM2		140	
TIM16		87	
TIM17		87	
USART		79	
SYSCFG		22	
CRC		8	

5.3.2 General operating conditions

Table 14. General operating conditions

Symbol	Parameter	Conditions	Min.	Max.	Unit
f _{HCLK}	Internal AHB clock frequency		1	64	MHz
f _{PCLK0}	Internal APB0 clock		1	64	
f _{PCLK1}	Internal APB1 clock frequency		1 ⁽¹⁾	64	
f _{PCLK2}	Internal APB2 clock frequency		16	32	
V _{DD}	Standard operating voltage		1.7	3.6	V
V _{FBSMPS}	SMPS feedback voltage		1.4	3.6	
V _{DDRF}	Minimum RF voltage		1.7	3.6	
V _{IN}	I/O input voltage		-0.3	VDD+0.3	
P _D	Power dissipation at T _A =105 °C ⁽²⁾	QFN32 package		30	mW
T _A	Ambient temperature	Maximum power dissipation	-40	105	°C
T _J	Junction temperature range		-40	105	

1. It could be 0 if all the peripherals are disabled.
2. T_A cannot exceed T_J max.

5.3.3 RF general characteristics

All performance data are referred to a 50 Ω antenna connector, via reference design.

Table 15. Bluetooth Low Energy RF general characteristics

Symbol	Parameter	Test conditions	Min.	Typ.	Max.	Unit
F _{RANGE}	Frequency range ⁽¹⁾		2400		2483.5	MHz
RF _{CH}	RF channel center frequency ⁽¹⁾		2402		2480	
PLL _{RES}	RF channel spacing ⁽¹⁾			2		MHz
ΔF	Frequency deviation ⁽¹⁾			250		kHz
Δf ₁	Frequency deviation average ⁽¹⁾		450		550	kHz
C _{Fdev}	Center frequency deviation ⁽¹⁾	During the packet and including both initial frequency offset and drift			±150	kHz
Δfa	Frequency deviation Δf ₂ (average) / Δf ₁ (average) ⁽¹⁾		0.80			
R _{gfsk}	On-air data rate ⁽¹⁾		1		2	Mbps
ST _{acc}	Symbol time accuracy ⁽¹⁾				±50	ppm
MOD	Modulation scheme		GFSK			
BT	Bandwidth-bit period product			0.5		
M _{index}	Modulation index ⁽¹⁾		0.45	0.5	0.55	
P _{MAX}	Maximum output	At antenna connector, VSMP5 = 1.9 V, LDO code		+8		dBm
P _{MIN}	Minimum output	At antenna connector		-20		dBm
PRFC	RF power accuracy	@ 27 °C		±1.5		dB
		All temperatures		±2.5		

1. Tested according to Bluetooth SIG radio frequency physical layer (RF PHY) test suite (not tested in production).

5.3.4 RF transmitter characteristics

All performance data are referred to a 50 Ω antenna connector, via reference design.

Table 16. Bluetooth Low Energy RF transmitter characteristics at 1 Mbps not coded

Symbol	Parameter	Test conditions	Min.	Typ.	Max.	Unit
P _{BW1M}	6 dB bandwidth for modulated carrier	Using resolution bandwidth of 100 kHz	500			kHz
P _{RF1, 1 Ms/s}	In-band emission at ±2 MHz ⁽¹⁾	Using resolution bandwidth of 100 kHz and average detector			-20	dBm
P _{RF2, 1 Ms/s}	In-band emission at ±[3+n]MHz, where n=0,1,2.. ⁽¹⁾	Using resolution bandwidth of 100 kHz and average detector			-30	dBm
P _{SPUR}	Spurious emission	Harmonics included. Using resolution bandwidth of 1 MHz and average detector			-41	dBm
F _{reqdrift}	Frequency drift ⁽¹⁾	Integration interval #n – integration interval #0, where n=2,3,4..k	-50		+50	kHz
I _{Freqdrift}	Initial carrier frequency drift ⁽¹⁾	Integration interval #1 – integration interval #0	-23		+23	kHz
I _{ntFreqdrift}	Intermediate carrier frequency drift ⁽¹⁾	Integration interval #n – integration interval #(n-5), where n=6,7,8..k	-20		+20	kHz
Drift Rate max	Maximum drift rate ⁽¹⁾	Between any two 10-bit groups separated by 50 μs	-20		+20	kHz/50 μs
Z _{RF1}	Optimum RF load (impedance at RF1 pin)	@ 2440 MHz		40		Ω

1. Tested according to Bluetooth SIG radio frequency physical layer (RF PHY) test suite (not tested in production).

Table 17. Bluetooth Low Energy RF transmitter characteristics at 2 Mbps not coded

Symbol	Parameter	Test conditions	Min.	Typ.	Max.	Unit
P _{BW1M}	6 dB bandwidth for modulated carrier	Using resolution bandwidth of 100 kHz	670			kHz
P _{RF1} , 2 Ms/s	In-band emission at ±4 MHz ⁽¹⁾	Using resolution bandwidth of 100 kHz and average detector			-20	dBm
P _{RF2} , 2 Ms/s	In-band emission at ±5 MHz ⁽¹⁾	Using resolution bandwidth of 100 kHz and average detector			-20	dBm
P _{RF3} , 2 Ms/s	In-band emission at ±[6+n]MHz, where n=0,1,2.. ⁽¹⁾	Using resolution bandwidth of 100 kHz and average detector			-30	dBm
P _{SPUR}	Spurious emission	Harmonics included. Using resolution bandwidth of 1 MHz and average detector			-41	dBm
Freq _{drift}	Frequency drift ⁽¹⁾	Integration interval #n – integration interval #0, where n=2,3,4..k	-50		+50	kHz
IFreq _{drift}	Initial carrier frequency drift ⁽¹⁾	Integration interval #1 – integration interval #0	-23		+23	kHz
IntFreq _{drift}	Intermediate carrier frequency drift ⁽¹⁾	Integration interval #n – integration interval #(n-5), where n=6,7,8..k	-20		+20	kHz
DriftRate _{max}	Maximum drift rate ⁽¹⁾	Between any two 20-bit groups separated by 50 μs	-20		+20	kHz/50μs
Z _{RF1}	Optimum RF load (impedance at RF1 pin)	@ 2440 MHz		40		Ω

1. Tested according to Bluetooth SIG radio frequency physical layer (RF PHY) test suite (not tested in production).

Table 18. Bluetooth Low Energy RF transmitter characteristics at 1 Mbps LE coded (S=8)

Symbol	Parameter	Test conditions	Min.	Typ.	Max.	Unit
P _{BW}	6 dB bandwidth for modulated carrier	Using resolution bandwidth of 100 kHz	500			kHz
P _{RF1} , LE coded	In-band emission at ±2 MHz ⁽¹⁾	Using resolution bandwidth of 100 kHz and average detector			-20	dBm
P _{RF2} , LE coded	In-band emission at ±[3+n] MHz, where n=0,1,2.. ⁽¹⁾	Using resolution bandwidth of 100 kHz and average detector			-30	dBm
P _{SPUR}	Spurious emission	Harmonics included. Using resolution bandwidth of 1 MHz and average detector			-41	dBm
Freq _{drift}	Frequency drift ⁽¹⁾	Integration interval #n – integration interval #0, where n=1,2,3..k	-50		+50	kHz
IFreq _{drift}	Initial carrier frequency drift ⁽¹⁾	Integration interval #3 – integration interval #0	-19.2		+19.2	kHz
IntFreq _{drift}	Intermediate carrier frequency drift ⁽¹⁾	Integration interval #n – integration interval #(n-3), where n=7,8,9..k	-19.2		+19.2	kHz
DriftRate _{max}	Maximum drift rate ⁽¹⁾	Between any two 16-bit groups separated by 48 μs	-19.2		+19.2	kHz/48 μs
Z _{RF1}	Optimum RF load (Impedance at RF1 pin)	@ 2440 MHz		40		Ω

1. Tested according to Bluetooth SIG radio frequency physical layer (RF PHY) test suite (not tested in production).

5.3.5 RF receiver characteristics

All performance data are referred to a 50 Ω antenna connector, via reference design.

Table 19. Bluetooth Low Energy RF receiver characteristics at 1 Msym/s uncoded

Symbol	Parameter	Test conditions	Min.	Typ.	Max.	Unit
RX _{SENS}	Sensitivity	PER < 30.8%	-	-97		dBm
P _{SAT}	Saturation	PER < 30.8%		8		dBm
Z _{RF1}	Optimum RF source (impedance at RF1 pin)	@ 2440 MHz		40		Ω
RF selectivity with BLE equal modulation on interfering signal						
C/I _{CO-channel}	Co-channel interference $f_{RX} = f_{interference}$	Wanted signal = -67 dBm, PER < 30.8%		8		dBc
C/I _{1 MHz}	Adjacent interference $f_{interference} = f_{RX} \pm 1 \text{ MHz}$	Wanted signal = -67 dBm, PER < 30.8%		-1		dBc
C/I _{2 MHz}	Adjacent Interference $f_{interference} = f_{RX} \pm 2 \text{ MHz}$	Wanted signal = -67 dBm, PER < 30.8%		-35		dBc
C/I _{3 MHz}	Adjacent interference $f_{interference} = f_{RX} \pm (3+n) \text{ MHz}$ [n = 0,1,2...]	Wanted signal = -67 dBm, PER < 30.8%		-47		dBc
C/I _{Image}	Image frequency interference $f_{interference} = f_{image}$	Wanted signal = -67 dBm, PER < 30.8%		-25		dBc
C/I _{Image±1 MHz}	Adjacent channel-to-image frequency $f_{interference} = f_{image} \pm 1 \text{ MHz}$	Wanted signal = -67 dBm, PER < 30.8%		-25		dBc
Out of band blocking (interfering signal CW)						
C/I _{Block}	Interfering signal frequency 30 MHz – 2000 MHz	Wanted signal = -67 dBm, PER < 30.8%, measurement resolution 10 MHz		5		dB
C/I _{Block}	Interfering signal frequency 2003 MHz – 2399 MHz	Wanted signal = -67 dBm, PER < 30.8%, measurement resolution 3 MHz		-5		dB
C/I _{Block}	Interfering signal frequency 2484 MHz – 2997 MHz	Wanted signal = -67 dBm, PER < 30.8%, measurement resolution 3 MHz		-5		dB
C/I _{Block}	Interfering signal frequency 3000 MHz – 12.75 GHz	Wanted signal = -67 dBm, PER < 30.8%, measurement resolution 25 MHz		10		dB
Intermodulation characteristics (CW signal at f ₁ , BLE interfering signal at f ₂)						
P_IM(3)	Input power of IM interferer at 3 and 6 MHz distance from wanted signal	Wanted signal = -64 dBm, PER < 30.8%		-27		dBm
P_IM(-3)	Input power of IM interferer at -3 and -6 MHz distance from wanted signal	Wanted signal = -64 dBm, PER < 30.8%		-40		dBm
P_IM(4)	Input power of IM interferer at ±4 and ±8 MHz distance from wanted signal	Wanted signal = -64 dBm, PER < 30.8%		-32		dBm
P_IM(5)	Input power of IM interferer at ±5 and ±10 MHz distance from wanted signal	Wanted signal = -64 dBm, PER < 30.8%		-32		dBm

Table 20. Bluetooth Low Energy RF receiver characteristics at 2 Msym/s uncoded

Symbol	Parameter	Test conditions	Min.	Typ.	Max.	Unit
RX _{SENS}	Sensitivity	PER < 30.8%		-94		dBm
P _{SAT}	Saturation	PER < 30.8%		8		dBm
Z _{RF1}	Optimum RF source (impedance at RF1 pin)	@ 2440 MHz		40		Ω

Symbol	Parameter	Test conditions	Min.	Typ.	Max.	Unit
RF selectivity with BLE equal modulation on interfering signal						
$C/I_{\text{CO-channel}}$	Co-channel interference $f_{\text{RX}} = f_{\text{interference}}$	Wanted signal= -67 dBm, PER < 30.8%		8		dBc
$C/I_{2 \text{ MHz}}$	Adjacent interference $f_{\text{interference}} = f_{\text{RX}} \pm 2 \text{ MHz}$	Wanted signal = -67 dBm, PER < 30.8%		-14		dBc
$C/I_{4 \text{ MHz}}$	Adjacent interference $f_{\text{interference}} = f_{\text{RX}} \pm 4 \text{ MHz}$	Wanted signal = -67 dBm, PER < 30.8%		-41		dBc
$C/I_{6 \text{ MHz}}$	Adjacent interference $f_{\text{interference}} = f_{\text{RX}} \pm (6+2n) \text{ MHz}$ [n = 0, 1, 2...]	Wanted signal = -67 dBm, PER < 30.8%		-45		dBc
C/I_{Image}	Image frequency interference $f_{\text{interference}} = f_{\text{image-2M}}$	Wanted signal = -67 dBm, PER < 30.8%		-25		dBc
$C/I_{\text{Image} \pm 1 \text{ MHz}}$	Adjacent channel-to-image frequency	Wanted signal= -67 dBm, PER < 30.8%		-14		dBc
	$f_{\text{interference}} = f_{\text{image-2M}} \pm 2 \text{ MHz}$					
Out of band blocking (interfering signal CW)						
C/I_{Block}	Interfering signal frequency 30 MHz – 2000 MHz	Wanted signal= -67 dBm, PER < 30.8%, measurement resolution 10 MHz		5		dB
C/I_{Block}	Interfering signal frequency 2003 MHz – 2399 MHz	Wanted signal= -67 dBm, PER < 30.8%, measurement resolution 3 MHz		-5		dB
C/I_{Block}	Interfering signal frequency 2484 MHz – 2997 MHz	Wanted signal= -67 dBm, PER < 30.8%, measurement resolution 3 MHz		-5		dB
C/I_{Block}	Interfering signal frequency 3000 MHz – 12.75 GHz	Wanted signal= -67 dBm, PER < 30.8%, measurement resolution 25 MHz		10		dB
Intermodulation characteristics (CW signal at f_1 , BLE interfering signal at f_2)						
$P_{\text{IM}(6)}$	Input power of IM interferer at 6 and 12 MHz distance from wanted signal	Wanted signal= -64 dBm, PER < 30.8%		-27		dBm
$P_{\text{IM}(-6)}$	Input power of IM interferer at -6 and -12 MHz distance from wanted signal	Wanted signal= -64 dBm, PER < 30.8%		-30		dBm
$P_{\text{IM}(8)}$	Input power of IM interferer at ± 8 and ± 16 MHz distance from wanted signal	Wanted signal= -64 dBm, PER < 30.8%		-30		dBm
$P_{\text{IM}(10)}$	Input power of IM interferer at ± 10 and ± 20 MHz distance from wanted signal	Wanted signal= -64 dBm, PER < 30.8%		-28		dBm

Table 21. Bluetooth Low Energy RF receiver characteristics at 1 Msym/s LE coded (S=2)

Symbol	Parameter	Test conditions	Min.	Typ.	Max.	Unit
RX _{SENS}	Sensitivity	PER < 30.8%	-	-100		dBm
P _{SAT}	Saturation	PER < 30.8%		8		dBm
Z _{RF1}	Optimum RF source (impedance at RF1 pin)	@ 2440 MHz		40		Ω
RF selectivity with BLE equal modulation on interfering signal						
C/I _{CO-channel}	Co-channel interference $f_{RX} = f_{interference}$	Wanted signal = -79 dBm, PER < 30.8%		2		dBc
C/I _{1 MHz}	Adjacent interference $f_{interference} = f_{RX} \pm 1 \text{ MHz}$	Wanted signal = -79 dBm, PER < 30.8%		-5		dBc
C/I _{2 MHz}	Adjacent interference $f_{interference} = f_{RX} \pm 2 \text{ MHz}$	Wanted signal = -79 dBm, PER < 30.8%		-38		dBc
C/I _{3 MHz}	Adjacent interference $f_{interference} = f_{RX} \pm (3+n) \text{ MHz}$ [n = 0,1,2...]	Wanted signal = -79 dBm, PER < 30.8%		-50		dBc
C/I _{Image}	Image frequency interference $f_{interference} = f_{image}$	Wanted signal = -79 dBm, PER < 30.8%		-30		dBc
C/I _{Image±1 MHz}	Adjacent channel-to-image frequency $f_{interference} = f_{image} \pm 1 \text{ MHz}$	Wanted signal = -79 dBm, PER < 30.8%		-34		dBc

Table 22. Bluetooth Low Energy RF receiver characteristics at 1 Msym/s LE coded (S=8)

Symbol	Parameter	Test conditions	Min.	Typ.	Max.	Unit
RX _{SENS}	Sensitivity	PER < 30.8%	-	-104		dBm
P _{SAT}	Saturation	PER < 30.8%		8		dBm
Z _{RF1}	Optimum RF source (impedance at RF1 pin)	@ 2440 MHz		40		Ω
RF selectivity with BLE equal modulation on interfering signal						
C/I _{CO-channel}	Co-channel interference $f_{RX} = f_{interference}$	Wanted signal = -79 dBm, PER < 30.8%		1		dBc
C/I _{1 MHz}	Adjacent interference $f_{interference} = f_{RX} \pm 1 \text{ MHz}$	Wanted signal = -79 dBm, PER < 30.8%		-4		dBc
C/I _{2 MHz}	Adjacent interference $f_{interference} = f_{RX} \pm 2 \text{ MHz}$	Wanted signal = -79 dBm, PER < 30.8%		-39		dBc
C/I _{3 MHz}	Adjacent interference $f_{interference} = f_{RX} \pm (3+n) \text{ MHz}$ [n = 0,1,2...]	Wanted signal = -79 dBm, PER < 30.8%		-53		dBc
C/I _{Image}	Image frequency interference $f_{interference} = f_{image}$	Wanted signal = -79 dBm, PER < 30.8%		-33		dBc
C/I _{Image ± 1 MHz}	Adjacent channel-to-image frequency $f_{interference} = f_{image} \pm 1 \text{ MHz}$	Wanted signal = -79 dBm, PER < 30.8%		-32		dBc

5.3.6 Embedded reset and power control block characteristics

Table 23. Embedded reset and power control block characteristics

Symbol	Parameter	Test conditions	Min.	Typ.	Max.	Unit
TRSTTEMPO	Reset temporization after PDR is detected	VDD rising			500	us
VPDR	Power-down reset threshold			1.58		V
VPVD0	PVD0 threshold	PVD0 threshold at the falling edge of VDDIO		2.05		
VPVD1	PVD1 threshold	PVD1 threshold at the falling edge of VDDIO		2.21		
VPVD2	PVD2 threshold	PVD2 threshold at the falling edge of VDDIO		2.36		
VPVD3	PVD3 threshold	PVD3 threshold at the falling edge of VDDIO		2.53		
VPVD4	PVD4 threshold	PVD4 threshold at the falling edge of VDDIO		2.64		
VPVD5	PVD5 threshold	PVD5 threshold at the falling edge of VDDIO		2.82		
VPVD6	PVD6 threshold	PVD6 threshold at the falling edge of VDDIO		2.91		
VPVD7	PVD threshold for VIN_PVD	PVD7 threshold (VBGP) at the falling edge of VIN_PVD		1		

5.3.7 Supply current characteristics

The current consumption is a function of several parameters and factors such as: the operating voltage, ambient temperature, I/O pin loading, device software configuration, operating frequencies, I/O pin switching rate, program location in memory and executed binary code.

The MCU is put under the following conditions:

- All I/O pins are in analog input mode
- All peripherals are disabled except when explicitly mentioned
- The Flash memory access time is adjusted with the minimum wait states number
- When the peripherals are enabled $f_{PCLK} = f_{HCLK}$

Table 24. Current consumption

Symbol	Parameter	Conditions	Typ.			Unit
			25 °C	85 °C	105 °C	
I _{DD} (RUN)	Supply current in RUN mode	f _{HCLK} = 64 MHz All peripherals disabled	1821	1863	1898	μA
		f _{HCLK} = 32 MHz All peripherals disabled	1594	1634	1669	
		f _{HCLK} = 16 MHz All peripherals disabled	1481	1521	1554	
I _{DD} (DEEPSTOP)	Supply current in DEEPSTOP ⁽¹⁾	Clock OFF	654	3930	8870	nA
		Clock source LSI	1214	4556	9530	
		Clock source LSI RTC ON	1272	4653	9674	
		Clock source LSI IWDG ON	1232	4584	9569	
		Clock source LSI RTC, LPUART and IWDG ON	1291	4682	9722	
		Clock source LSE	991	4828	10596	

Symbol	Parameter	Conditions	Typ.			Unit
			25 °C	85 °C	105 °C	
I _{DD} (DEEPSTOP)	Supply current in DEEPSTOP ⁽¹⁾	Clock source LSE RTC ON	1010	4344	9316	nA
		Clock source LSE IWDG ON	971	4277	9242	
		Clock source LSE. LPUART ON	1076	4458	9426	
		Clock source LSE RTC, LUART and IWDG ON	1150	4585	9646	
I _{DD} (SHUTDOWN)	Supply current in SHUTDOWN		15	350	1090	
I _{DD} (RST)	Current under reset condition		1098	1160	1230	μA

1. The current consumption in DEEPSTOP is measured considering the entire SRAM retained.

5.3.8 Wake-up time from low power modes

The wake-up times reported are the latency between the event and the execution of the instruction. The device goes to low-power mode after WFI (wait for interrupt) instructions.

Table 25. Low power mode wake-up timing

Symbol	Parameter	Conditions	Typ.	Unit
T _{WUDEEPSTOP}	Wake-up time from DEEPSTOP mode to RUN mode	Wake-up from GPIO VDD = 3.3 V Flash memory	170	μs

5.3.9 High speed crystal requirements

The high speed external oscillator must be supplied with an external 32 MHz crystal that is specified for a 6 to 8 pF loading capacitor. The BlueNRG-LPS includes internal programmable capacitances that can be used to tune the crystal frequency in order to compensate the PCB parasitic one. These internal load capacitors are made by a fixed one, in parallel with a 6-bit binary weighted capacitor bank. Thanks to low CL step size (1-bit is typically 0.07 pF), very fine crystal tuning is possible. With a typical XTAL sensitivity of -14 ppm/pF, it is possible to trim a 32 MHz crystal, with a resolution of 1 ppm.

The requirements for the external 32 MHz crystal are reported in the table below.

Table 26. HSE crystal requirements

Symbol	Parameter	Conditions	Min.	Typ.	Max.	Unit
f _{NOM}	Oscillator frequency			32		MHz
f _{TOL}	Frequency tolerance	Includes initial accuracy, stability over temperature, aging and frequency pulling due to incorrect load capacitance			±50	ppm
ESR	Equivalent series resistance				100	Ω
P _D	Drive level				100	μW
CL	HSE crystal load capacitance	27 °C, typical corner GMCONF = 3	5 ⁽¹⁾	7 ⁽²⁾	9.2 ⁽³⁾	pF
CLstep	HSE crystal load capacitance 1-bit value	27 °C, GMCONF = 3 XOTUNE code between 32 and 33		0.07		pF

1. XOTUNE programed at minimum code = 0

2. XOTUNE programed at center code = 32

3. XOTUNE programed at maximum code = 63

5.3.10 Low speed crystal requirements

Low speed clock can be supplied with an external 32.768 kHz crystal oscillator. Requirements for the external 32.768 kHz crystal are reported in the table below.

Table 27. LSE crystal requirements

Symbol	Parameter	Conditions	Min.	Typ.	Max.	Unit
f_{NOM}	Nominal frequency			32.768		kHz
ESR	Equivalent series resistance				90	k Ω
P_{D}	Drive level				0.1	μW

5.3.11 High speed ring oscillator characteristics

Table 28. HSI oscillator characteristics

Symbol	Parameter	Conditions	Min.	Typ.	Max.	Unit
f_{NOM}	Nominal frequency			64		MHz

5.3.12 Low speed ring oscillator characteristics

Table 29. LSI oscillator characteristics

Symbol	Parameter	Conditions	Min.	Typ.	Max.	Unit
f_{NOM}	Nominal frequency			33		kHz
$\Delta f_{\text{RO_}\Delta\text{T}}/f_{\text{RO}}$	Frequency spread vs. temperature	Standard deviation		140		ppm/ $^{\circ}\text{C}$

5.3.13 PLL characteristics

Characteristics measured over recommended operating conditions unless otherwise specified.

Table 30. PLL characteristics

Symbol	Parameter	Conditions	Min.	Typ.	Max.	Unit
PN_{SYNTH}	RF carrier phase noise	At ± 1 MHz offset from carrier (measured at 2.4 GHz)		-110		dBc/Hz
		At 2.4 GHz ± 3 MHz offset from carrier (measured at 2.4 GHz)		-114		dBc/Hz
		At 2.4 GHz ± 6 MHz offset from carrier (measured at 2.4 GHz)		-128		dBc/Hz
		At ± 25 MHz offset from carrier		-135		dBc/Hz
$LOCK_{\text{TIMETX}}$	PLL lock time to TX	With calibration @2.5 ppm		150		μs
$LOCK_{\text{TIMERX}}$	PLL lock time to RX	With calibration @2.5 ppm		110		μs
$LOCK_{\text{TIMERXTX}}$	PLL lock time RX to TX	Without calibration @2.5 ppm		47		μs
$LOCK_{\text{TIMETXRX}}$	PLL lock time TX to RX	Without calibration @2.5 ppm		32		μs

5.3.14 Flash memory characteristics

The characteristics below are guaranteed by design.

Table 31. Flash memory characteristics

Symbol	Parameter	Test conditions	Typ.	Max.	Unit
t_{prog}	32-bit programming time		20	40	μs
t_{prog_burst}	4x32-bit burst programming time		4x20	4x40	
t_{ERASE}	Page (2 kbyte) erase time		20	40	ms
t_{ME}	Mass erase time		20	40	
I_{DD}	Average consumption from VDD	Write mode	3		mA
		Erase mode	3		
		Mass erase	5		

Table 32. Flash memory endurance and data retention

Symbol	Parameter	Test conditions	Min.	Unit
N_{END}	Endurance	$T_A = -40$ to $+105$ °C	10	kcycles
t_{RET}	Data retention	$T_A = 105$ °C	10	Years

5.3.15 Electrostatic discharge (ESD)

Electrostatic discharges (a positive then a negative pulse separated by 1 second) are applied to the pins of each sample according to each pin combination. The sample size depends on the number of supply pins in the device (3 parts x (n + 1) supply pins). This test conforms to the ANSI/JEDEC standard.

Table 33. ESD absolute maximum ratings

Symbol	Parameter	Conditions	Class	Max. ⁽¹⁾	Unit
$V_{ESD(HBM)}$	Electrostatic discharge voltage (human body model)	Conforming to ANSI/ESDA/JEDEC JS-001	2	2000	V
$V_{ESD(CBM)}$	Electrostatic discharge voltage (charge device model)	Conforming to ANSI/ESDA/STM5.3.1 JS-002	C2a	500	

1. Guaranteed by design.

5.3.16 I/O port characteristics

Unless otherwise specified, the parameters given in the tables below are derived from tests performed under the conditions summarized in Table 14. General operating conditions. All I/Os are designed as CMOS-compliant.

Table 34. I/O static characteristics

Symbol	Parameter	Conditions	Min.	Typ.	Max.	Unit
V_{IL}	I/O input low level voltage	$1.62 \text{ V} < V_{DD} < 3.6 \text{ V}$			$0.3 \times V_{DD}$	V
V_{IH}	I/O input high level voltage		$0.7 \times V_{DD}$			
I_{lkg}	Input leakage current	$0 \leq V_{IN} \leq \text{Max}(V_{DDx})^{(1)}$			+/-100	nA
		$\text{Max}(V_{DDx})^{(1)} \leq V_{IN} \leq \text{Max}(V_{DDx})^{(1)} + 1 \text{ V}$			650	
		$\text{Max}(V_{DDx})^{(1)} + 1 \text{ V} < V_{IN} \leq 5.5 \text{ V}$			200	
R_{PU}	Pull-up resistor	$V_{IN} = \text{GND}$	25	40	55	k Ω
R_{PD}	Pull-down resistor	$V_{IN} = V_{DD}$	25	40	55	

Symbol	Parameter	Conditions	Min.	Typ.	Max.	Unit
C_{IO}	I/O pin capacitance			5		pF

1. $Max(VDDx)$ is the maximum value among all the I/O supplies.

All I/Os are CMOS-compliant (no software configuration required).

GPIOs (general purpose input/outputs) can sink or source up to ± 8 mA and sink or source up to ± 20 mA (with a relaxed V_{OL} / V_{OH}).

In the user application, the number of I/O pins that can drive current must be limited to respect the absolute maximum rating specified.

- The sum of currents sourced by all I/Os on VDD, plus the maximum consumption of MCU sourced on VDD, cannot exceed the absolute maximum rating $\Sigma IVDD$
- The sum of currents sunk by all I/Os on VSS, plus the maximum consumption of the MCU sunk on GND, cannot exceed the absolute maximum rating $\Sigma IVGND$.

Table 35. Output voltage characteristics

Symbol	Parameter	Conditions	Min.	Max.	Unit
V_{OL}	Output low level voltage for I/O pin	CMOS port ⁽¹⁾ $ I_{IO} = 8$ mA $VDD \geq 2.7$ V		0.4	V
V_{OH}	Output high level voltage for I/O pin		VDD - 0.4		
V_{OL}	Output low level voltage for I/O pin	$ I_{IO} = 20$ mA $VDD \geq 2.7$ V		1.3	
V_{OH}	Output high level voltage for I/O pin		VDD - 1.3		
V_{OL}	Output low level voltage for I/O pin	$ I_{IO} = 4$ mA $VDD \geq 1.62$ V		0.4	
V_{OH}	Output high level voltage for I/O pin		VDD - 0.45		

1. CMOS outputs are compatible with JEDEC standards JESD36 and JESD52.

5.3.17

RSTN pin characteristics

The RSTN pin input driver uses CMOS technology. It is connected to a permanent pull-up resistor, RPU.

Unless otherwise specified, the parameters given in the table below are derived from tests performed under the ambient temperature and supply voltage conditions summarized in .

Table 36. RSTN pin characteristics

Symbol	Parameter	Test conditions	Min.	Typ.	Max.	Unit.
$V_{IL(RSTN)}$	RSTN input low level voltage				0.3 x VDD	V
$V_{IH(RSTN)}$	RSTN input high level voltage		0.7 x VDD			
$V_{hys(RSTN)}$	RSTN Schmitt trigger voltage hysteresis			200		mV
RPU	Weak pull-up equivalent resistor	$V_{IN} = GND$	25	40	55	k Ω

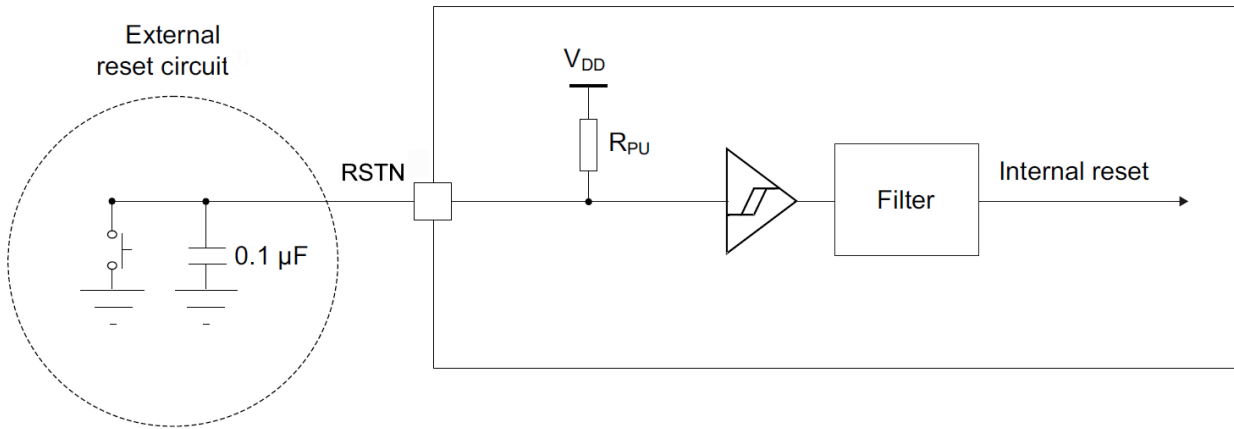
Figure 14. Recommended RSTN pin protection

Note: *The external reset circuit protects the device against parasitic resets. The user must ensure that the level on the RSTN pin can go below the $V_{IL}(RSTN)$ max. level specified in the table, otherwise the reset is not taken into account by the device. The external capacitor on RSTN must be placed as close as possible to the device.*

5.3.18 ADC characteristics

Table 37. ADC characteristics (HSI must be set to PLL mode)

Symbol	Parameter	Test conditions	Min.	Typ.	Max.	Units
Channels Diff	Number of channels for differential mode	QFN32, WLCSP36			4	
Channels SE	Number of channels for single ended mode	QFN32, WLCSP36			8	
IBAT _{ADCBIAS}	ADC biasing consumption at battery	Biasing blocks turned on		145		µA
IBAT _{ADCACTIVE}	ADC active consumption at battery	ADC activated in differential mode		185		µA
VDDA_VCAP	Analog supply voltage		1.2		1.32	V
R _{AIN}	Input impedance	In DC		250		kΩ
R _{in}	Internal access resistance	VBOOST is enabled for VDD < 2.7 V			550	Ω
C _{in}	Input sampling capacitor			4		pF
T _s	Sampling period	Default configuration		1		µs
T _{sw}	Sampling time	Default configuration		125		ns
DR	Output data rate			200		k samples/s
FRMT _{output}	Output data format			16		bits
TL	Latency time	200 kSps		5		µs
T _{STARTUP}	Start-up time	From ADC enable to conversion start			1	µs
DNL	Differential non-linearity			±0.7		bit
INL	Integral non-linearity			±1		bit

Symbol	Parameter	Test conditions	Min.	Typ.	Max.	Units
SNR Diff	Signal to noise ratio	Differential input @1 kHz, -1 dBFS, Fs = 800 kHz, DS=4		72		dB
STHD Diff	Signal to THD ratio (10 harmonics)	Differential input @1 kHz, -1 dBFS, Fs = 800 kHz, DS = 4		75		dB
ENOB Diff	Effective number of bits	Differential input @1 kHz, -1 dBFS, Fs = 800 kHz, DS = 4		11.5		bits
SNR SE	Signal-to-noise ratio	Single ended @1 kHz, -1 dBFS, Fs = 800 kHz, DS = 4		70		dB
STHD SE	Signal-to THD ratio (10 harmonics)	Single ended @1 kHz, -1 dBFS, Fs = 800 kHz, DS = 4		70		dB
ENOB SE	Effective number of bits	Single ended @1 kHz, -1 dBFS, Fs = 800 kHz, DS = 4		11		bits
	ADC_ERR_1V7	Absolute error when used for battery measurements at 1.7 V, 2.4 V, 3.0 V, 3.6 V		13		mV
	ADC_ERR_2V4			0		
	ADC_ERR_3V0			-9		
	ADC_ERR_3V6			-22		

5.3.19 Temperature sensor characteristics

Table 38. Temperature sensor characteristics

Symbol	Parameter	Conditions	Min.	Typ.	Max.	Unit
T _{rERR}	Error in temperature			±4		°C
T _{SLOPE}	Average temperature coefficient			8		bit/°C
T _{ICC}	Current consumption with AUXADC			415		µA
T _{TS-OUT}	Output code at 30 °C (+/-5 °C)			2533		bit

5.3.20 Timer characteristics

Table 39. TIM2/16/17 characteristics

Symbol	Parameter	Test conditions	Min.	Typ.	Max.	Unit
t _{res(TIM)}	Timer resolution time	f _{TIMxCLK} = 64 MHz		15.625		ns
R _{esTIM}	Timer resolution			16		bit
t _{COUNTER}	16-bit counter clock period	f _{TIMxCLK} = 64 MHz	0.015625		1024	µs
t _{MAX_COUNT}	Maximum possible count time	f _{TIMxCLK} = 64			67.10	s

Table 40. IWDG min./max. timeout period at 32 kHz (LSE)

Prescaler divider	PR[2:0] bits	Min. timeout RL[11:0] = 0x000	Max. timeout RL[11:0] = 0xFFFF	Unit
/4	0	0.125	512	ms
/8	1	0.250	1024	
/16	2	0.500	2048	

Prescaler divider	PR[2:0] bits	Min. timeout RL[11:0] = 0x000	Max. timeout RL[11:0] = 0xFFFF	Unit
/32	3	1.0	4096	ms
/64	4	2.0	8192	
/128	5	4.0	16384	
/256	6 or 7	8.0	32768	

5.3.21 I²C interface characteristics

The I²C interface meets the timing requirements of the I²C-Bus specifications and user manual rev. 03 for:

- Standard-mode (Sm): bit rate up to 100 kbit/s
- Fast-mode (Fm): bit rate up to 400 kbit/s
- Fast-mode plus (Fm+): bit rate up to 1 Mbit/s

SDA and SCL I/O requirements are met with the following restrictions: SDA and SCL I/O pins are not “true” open-drain. When configured as open-drain, the PMOS connected between the I/O pin and VDD is disabled, but is still present. The 20 mA output drive requirement in fast-mode plus is supported partially.

This limits the maximum load C_{load} supported in fast-mode plus, given by these formulas:

- $t_r(\text{SDA/SCL}) = 0.8473 \times R_p \times C_{load}$
- $R_p(\text{min.}) = [V_{DD} - V_{OL}(\text{max})] / I_{OL}(\text{max})$

where R_p is the I²C lines pull-up.

All I²C SDA and SCL I/Os embed an analog filter.

Table 41. I²C analog filter characteristics

Symbol	Parameter	Min.	Max.	Unit
tAF	Maximum pulse width of spikes that are suppressed by the analog filter	50	110	ns

5.3.22 SPI characteristics

The parameters for SPI are derived from tests performed according to f_{PCLKx} frequency and supply voltage conditions summarized in Table 14. General operating conditions.

- Output speed is set to OSPEEDRy[1:0] = 11
- Capacitive load C = 30 pF
- Measurement points are done at CMOS levels: $0.5 \times V_{DD}$

Table 42. SPI characteristics

Symbol	Parameter	Conditions	Min.	Typ.	Max.	Units
f_{SCK}	SPI clock frequency	Master mode		-	32	MHz
		Slave mode			32 ⁽¹⁾	
tsu(NSS)	NSS setup time		$4 / f_{PCLK}$	-	-	-
th(NSS)	NSS hold time		$2 / f_{PCLK}$	-	-	-
tw(SCKH), tw(SCKL)	SCK high and low time	Master mode	$1 / f_{PCLK} - 1.5$	$1 / f_{PCLK}$	$1 / f_{PCLK} + 1$	ns
tsu(MI)	Data input set-up time	Master mode	2	-	-	
tsu(SI)	Data input set-up time	Slave mode	1	-	-	
th(MI)	Data input hold time	Master mode	2	-	-	
th(SI)	Data input hold time	Slave mode	0	-	-	
t _a (SO)	Data output access time	Slave mode	6	-	30	

Symbol	Parameter	Conditions	Min.	Typ.	Max.	Units
$t_{dis(SO)}$	Data output disable time	Slave mode	6	-	32	ns
$t_{v(MO)}$	Data output valid time	Master mode	-	5	9	
$t_{v(SO)}$		Slave mode	-	12	35	
$t_{h(MO)}$	Data output hold time	Master mode	1	-	-	
$t_{h(SO)}$		Slave mode	6	-	-	

1. The maximum frequency in slave transmitter mode is determined by the sum of $t_{v(SO)}$ and $t_{su(MI)}$, which has to fit SCK low or high phase preceding the SCK sampling edge. This value can be achieved when the SPI communicates with a master having $t_{su(MI)} = 0$ while $duty(SCK) = 50\%$.

Figure 15. SPI timing diagram - slave mode and CPHA = 0

Figure 16. SPI timing diagram - slave mode and CPHA = 1

Figure 17. SPI timing diagram - master mode

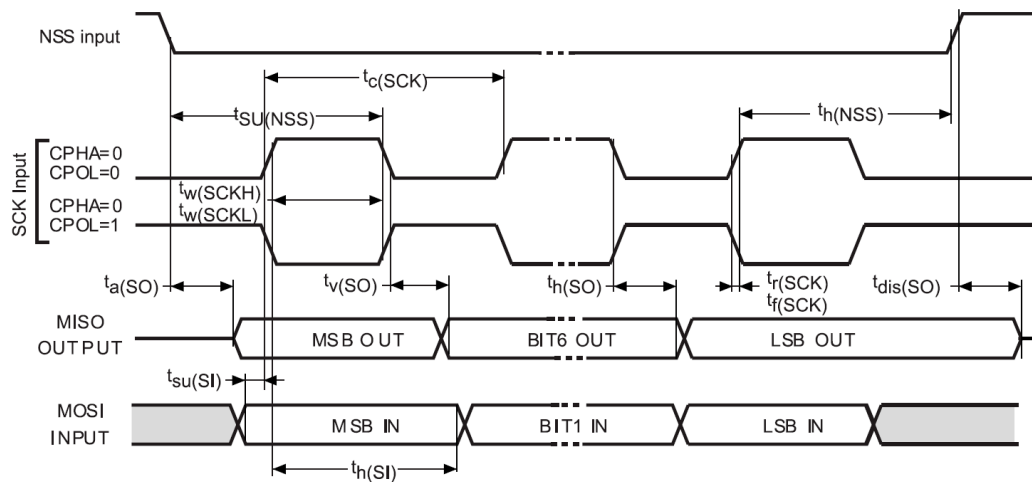
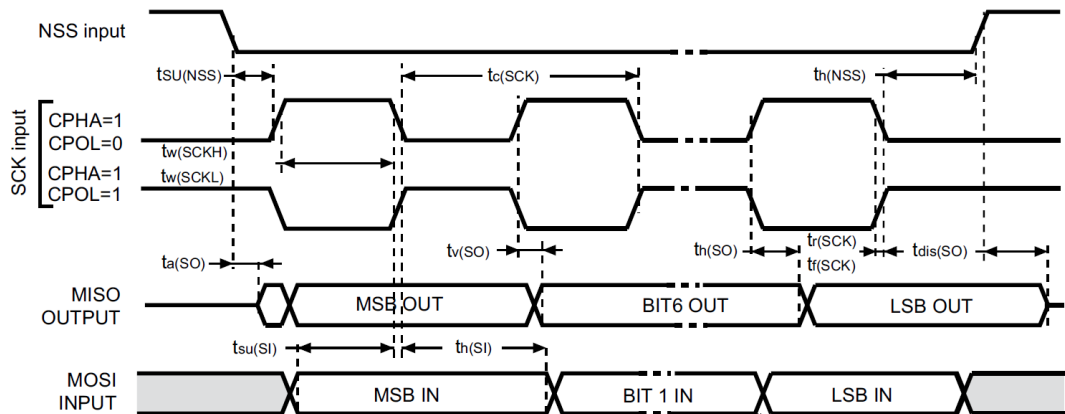
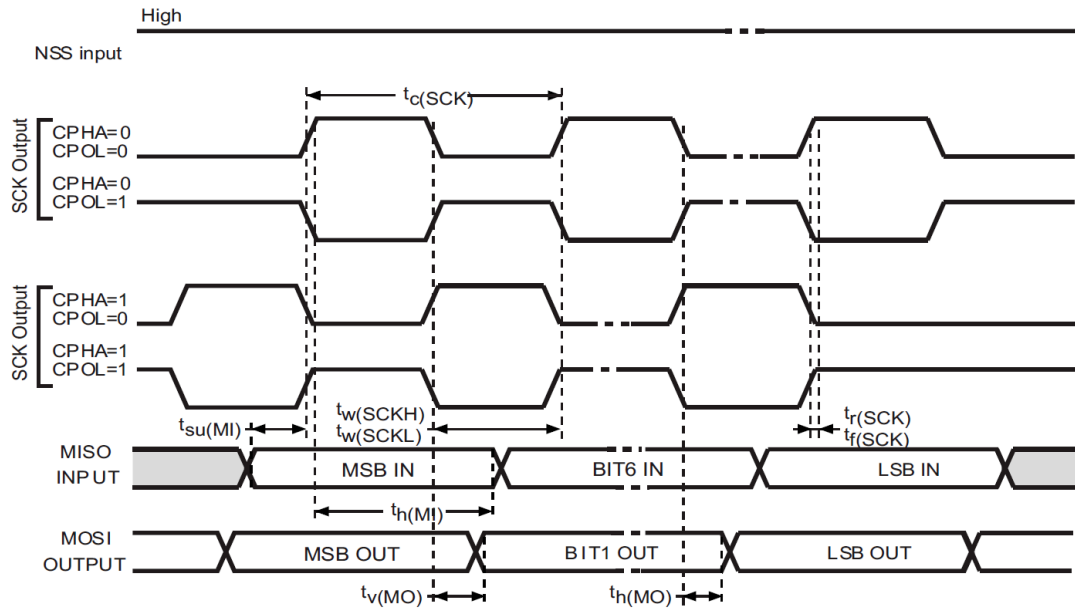

6 Package information

In order to meet environmental requirements, ST offers these devices in different grades of **ECOPACK** packages, depending on their level of environmental compliance. ECOPACK specifications, grade definitions and product status are available at: www.st.com. ECOPACK is an ST trademark.

6.1 QFN32 (5x5x0.9, pitch 0.5 mm) package information

Figure 18. QFN32 (5x5x0.9, pitch 0.5 mm) package outline

BOTTOM VIEW

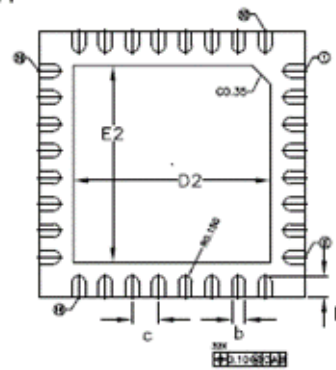

SIDE VIEW

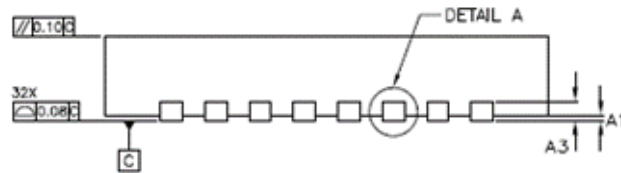

TOP VIEW

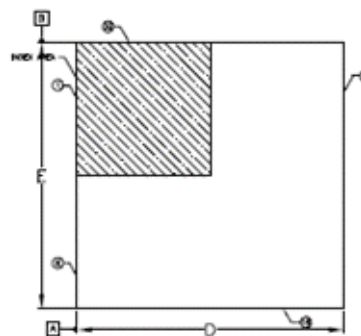

Table 43. QFN32 (5 x 5 x 0.9 pitch 0.5 mm) package mechanical data

Symbol	Min.	Typ.	Max.	Unit
A	0.90	0.95	1.00	mm
A1	0		0.05	
A3	0.20 Ref			
A3		0.20		
b	0.20	0.25	0.30	
D	4.90	5.00	5.10	
E	4.90	5.00	5.10	
D2	3.60	3.70	3.80	
E2	3.60	3.70	3.80	
e	0.50 BSC ⁽¹⁾			
L	0.30	0.40	0.50	
ddd			0.05	

1. Basic spacing between centers

Note: Tolerance of form and position is of 0.10 mm.

Figure 19. QFN32 (5x5x0.9, pitch 0.5 mm) package information recommended footprint

Figure 20. Carrier tape QFN32 5x5 specification

$A_0 = 7.25$
 $B_0 = 7.25$
 $K_0 = 0.75$

NOTES:

1. 10 SPROCKET HOLE PITCH CUMULATIVE TOLERANCE ± 0.2
2. CAMBER IN COMPLIANCE WITH IEC 481
3. POCKET POSITION RELATIVE TO SPROCKET HOLE MEASURED AS TRUE POSITION OF POCKET, NOT POCKET HOLE
4. A_0 AND B_0 ARE CALCULATED ON A PLANE AT A DISTANCE "R" ABOVE THE BOTTOM OF THE POCKET.

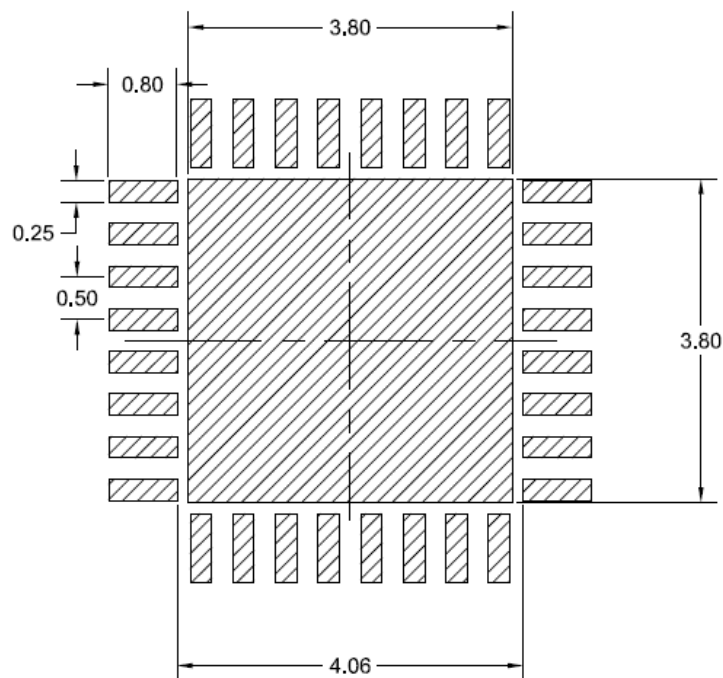
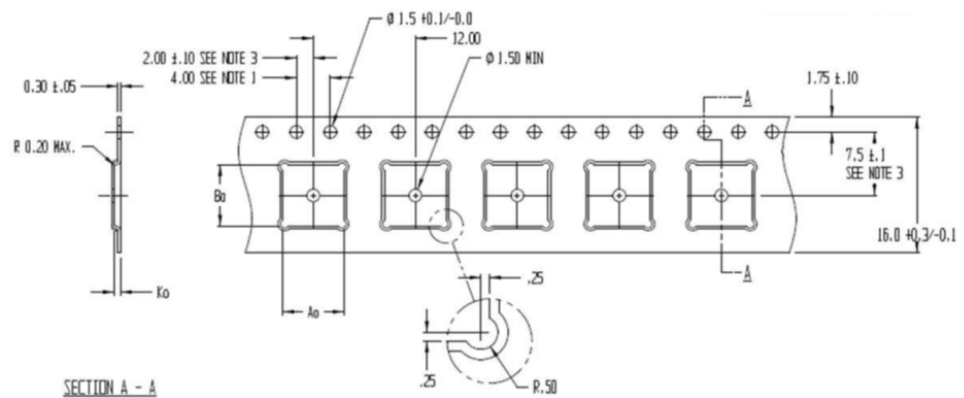
TITLE PART DRAWING NUMBER CD4080-A			
CARRIER TAPE			
TOLERANCES - UNLESS NOTED I.P.L. ± 0.2 Z.P.L. ± 0.10	MATERIAL PS4C	DWG SIZE B	
ALL DIMS IN MILLIMETERS PER ASME Y14.5M			
DATE 01/21/2010	SCALE 3:1	SHEET 1 OF 1	
PROJECT NO. 6337.00	DWG NO. T10805581	REV	

6.2 WLCSP36 package information

Figure 21. WLCSP36 (2.6525x 2.5925 x 0.4, pitch 0.4 mm) package outline (bumps view)

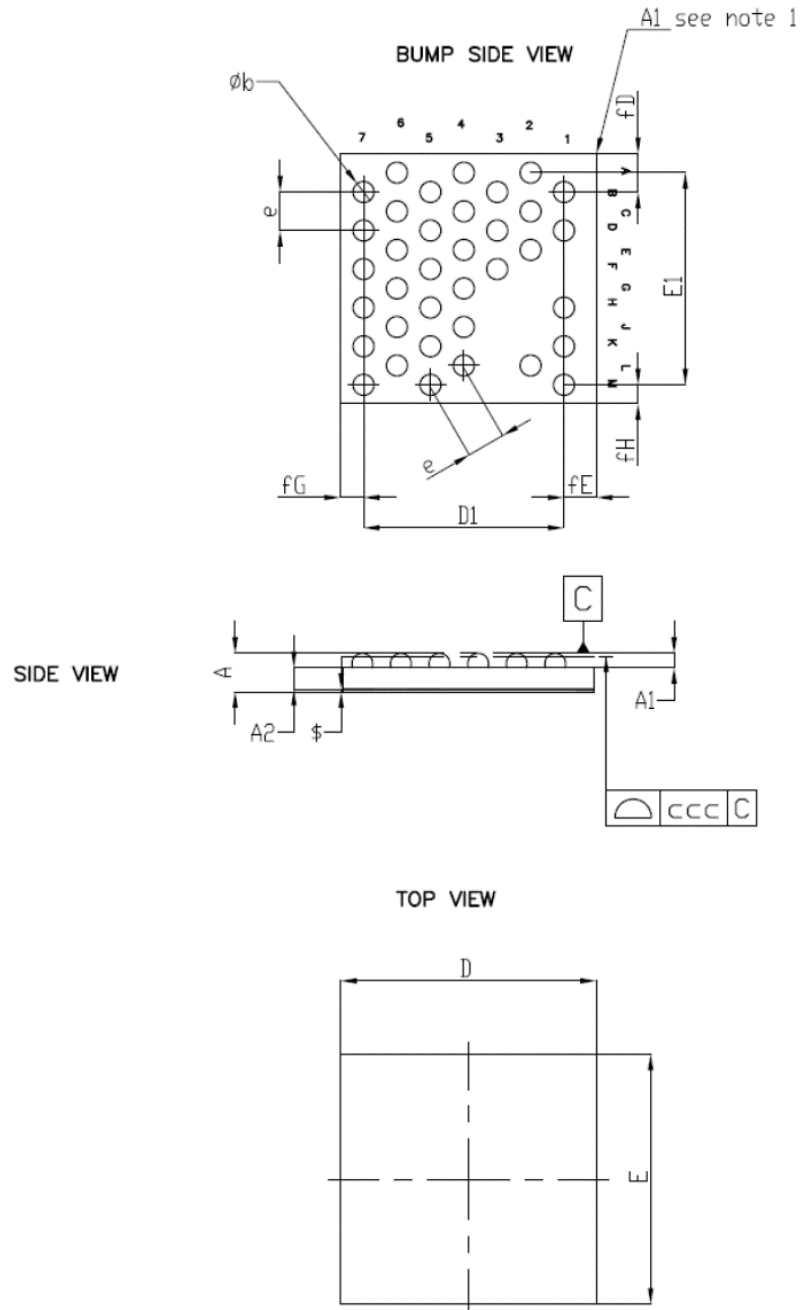
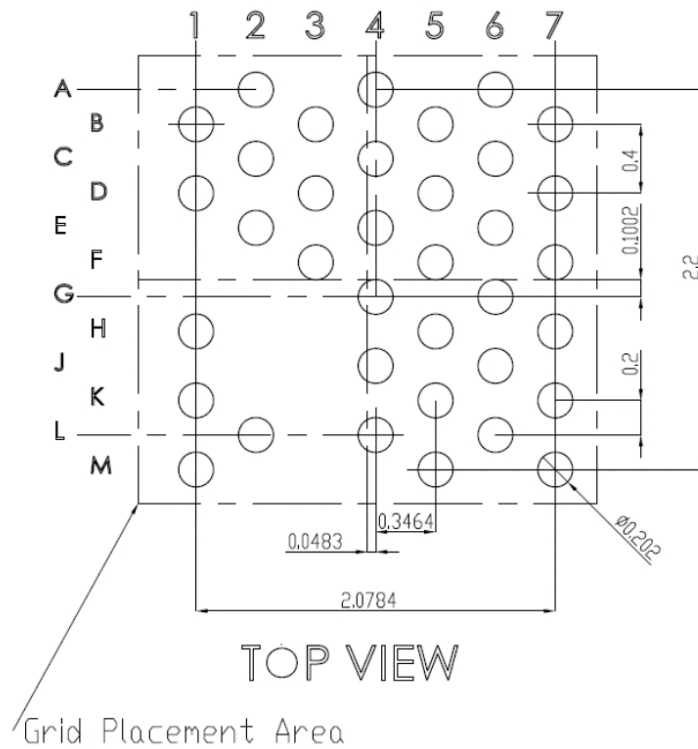

Table 44. WLCSP36 (2.6525x 2.5925 x 0.4, pitch 0.4 mm) mechanical data

Symbol	Millimeters		
	Min.	Typ.	Max.
A	0.378	0.400	0.422
A1	0.135	0.150	0.165
A2	0.209	0.225	0.241
b	0.193	0.218	0.243
D	2.6300	2.6525	2.6750
D1		2.078	
E	2.5700	2.5925	2.6150
E1		2.200	
e		0.400	
fD		0.397	
fE		0.335	
fG		0.239	
fH		0.196	
\$	0.022	0.025	0.028
ccc		0.030	

Figure 22. WLCSP36 (2.6525x 2.5925 x 0.4, pitch 0.4 mm) recommended footprint



6.3 Thermal characteristics

The maximum chip junction temperature ($T_{Jmax.}$) must never exceed the values in general operating conditions. The maximum chip-junction temperature, T_J max., in degrees Celsius, can be calculated using the equation:

$$T_{Jmax.} = T_{Amax.} + (PD_{max} \times \theta_{JA})$$

where:

- T_A max. is the maximum ambient temperature in °C
- θ_{JA} is the package junction-to-ambient thermal resistance, in °C/W
- PD max. is the sum of $PINT$ max. and PI/O max. (PD max. = $PINT$ max. + PI/O max.)
- $PINT$ max. is the product of IDD and VDD , expressed in Watt. This is the maximum chip internal power

PI/O max represents the maximum power dissipation on output pins:

- PI/O max. = $\Sigma (VOL \times IOL) + \Sigma ((VDD - VOH) \times IOH)$

taking into account the actual VOL / IOL and VOH / IOH of the I/Os at low and high level in the applications.

Note: When the SMPS is used, a portion of the power consumption is dissipated into the external inductor, therefore reducing the chip power dissipation. This portion depends mainly on the inductor ESR characteristics.

Note: As the radiated RF power is quite low (< 4 mW), it is not necessary to remove it from the chip power consumption.

Note: RF characteristics (such as: sensitivity, Tx power, consumption) are provided up to 85 °C.

Table 45. Package thermal characteristics

Symbol	Parameter	Value	Unit
θ_{JA}	Thermal resistance junction-ambient QFN32 - 5 mm x 5 mm	26.9	°C/W
	Thermal resistance junction-ambient WLCSP36 – 0.4 mm pitch	-	

7 Ordering information

Table 46. Ordering information

Order code	Package	Packing
BLUENRG-332xy	QFN32, WLCSP36	Tape and reel

Figure 23. Ordering information

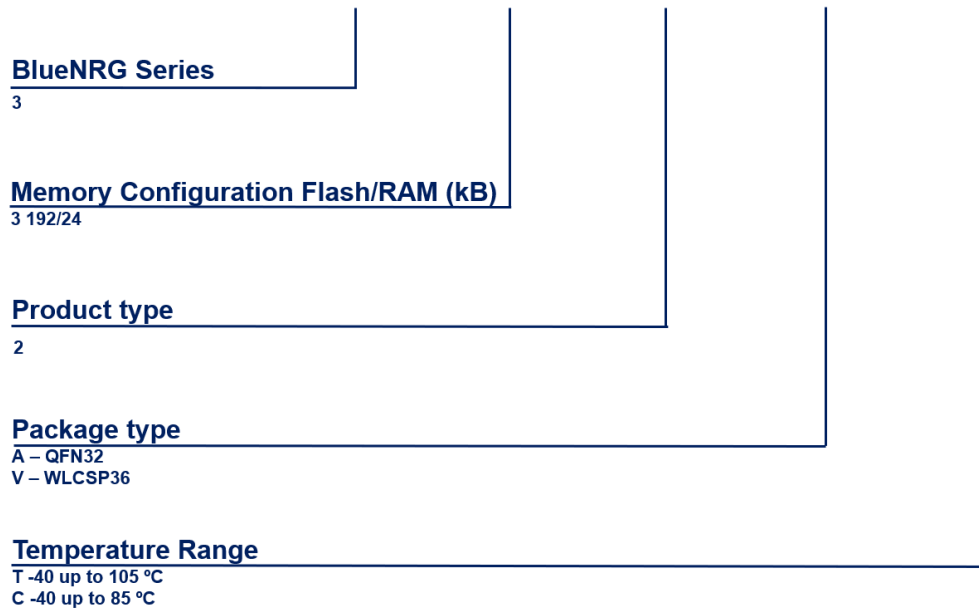

Revision history

Table 47. Document revision history

Date	Version	Changes
09-Dec-2021	1	Initial release.
13-Apr-2022	2	Updated Table 8. Voltage characteristics, Table 37. ADC characteristics (HSI must be set to PLL mode) and Table 23. Embedded reset and power control block characteristics.

Contents

1	Functional overview	5
1.1	System architecture	5
1.2	Arm® Cortex®-M0+ core with MPU	6
1.3	Memories	6
1.3.1	Embedded Flash memory	6
1.3.2	Embedded SRAM	6
1.3.3	Embedded ROM	6
1.3.4	Embedded OTP	6
1.3.5	Memory protection unit (MPU)	7
1.4	Security and safety	7
1.5	RF subsystem	7
1.5.1	RF front-end block diagram	7
1.6	Power supply management	8
1.6.1	SMPS step-down regulator	8
1.6.2	Power supply schemes	9
1.6.3	Linear voltage regulators	9
1.6.4	Power supply supervisor	10
1.7	Operating modes	10
1.7.1	RUN mode	11
1.7.2	DEEPSTOP mode	11
1.7.3	SHUTDOWN mode	12
1.8	Reset management	12
1.9	Clock management	13
1.10	Boot mode	15
1.11	Embedded UART bootloader	15
1.12	General purpose inputs/outputs (GPIO)	15
1.13	Direct memory access (DMA)	15
1.14	Nested vectored interrupt controller (NVIC)	16
1.15	Analog digital converter (ADC)	16
1.15.1	Temperature sensor	16
1.16	True random number generator (RNG)	17
1.17	Timers and watchdog	17
1.17.1	General-purpose timers (TIM2, TIM16, TIM17)	17
1.17.2	Independent watchdog (IWDG)	17
1.17.3	SysTick timer	17

1.18	Real-time clock (RTC)	17
1.19	Inter-integrated circuit interface (I ² C)	17
1.20	Universal synchronous/asynchronous receiver transmitter (USART)	18
1.21	LPUART	18
1.22	Serial peripheral interface (SPI)	19
1.23	Inter-IC sound (I2S)	19
1.24	Serial wire debug port	19
1.25	TX and RX event alert	19
1.26	Direction finding	20
2	Pinouts and pin description	21
3	Memory mapping	26
4	Application circuits	27
5	Electrical characteristics	29
5.1	Parameter conditions	29
5.1.1	Minimum and maximum values	29
5.1.2	Typical values	29
5.1.3	Typical curves	29
5.1.4	Loading capacitor	29
5.1.5	Pin input voltage	30
5.2	Absolute maximum ratings	30
5.3	Operating conditions	31
5.3.1	Summary of main performance	31
5.3.2	General operating conditions	34
5.3.3	RF general characteristics	34
5.3.4	RF transmitter characteristics	35
5.3.5	RF receiver characteristics	36
5.3.6	Embedded reset and power control block characteristics	40
5.3.7	Supply current characteristics	40
5.3.8	Wake-up time from low power modes	41
5.3.9	High speed crystal requirements	41
5.3.10	Low speed crystal requirements	42
5.3.11	High speed ring oscillator characteristics	42
5.3.12	Low speed ring oscillator characteristics	42
5.3.13	PLL characteristics	42
5.3.14	Flash memory characteristics	43
5.3.15	Electrostatic discharge (ESD)	43
5.3.16	I/O port characteristics	43

5.3.17	RSTN pin characteristics	44
5.3.18	ADC characteristics	45
5.3.19	Temperature sensor characteristics	46
5.3.20	Timer characteristics	46
5.3.21	I ² C interface characteristics	47
5.3.22	SPI characteristics	47
6	Package information	50
6.1	QFN32 (5x5x0.9, pitch 0.5 mm) package information	50
6.2	WLCSP36 package information	53
6.3	Thermal characteristics	55
7	Ordering information	56
	Revision history	57

List of tables

Table 1.	SRAM overview	6
Table 2.	Relationship between the low power modes and functional blocks	10
Table 3.	Pins description	23
Table 4.	Legend/abbreviations used in the pinout table	24
Table 5.	Alternate function port A	25
Table 6.	Alternate function port B	25
Table 7.	Application circuit external components	28
Table 8.	Voltage characteristics	30
Table 9.	Current characteristics	31
Table 10.	Thermal characteristics	31
Table 11.	Main performance SMPS ON	31
Table 12.	Main performance SMPS bypassed	33
Table 13.	Peripheral current consumption at VDD = 3.3 V, system clock (CLK_SYS), SMPS on	34
Table 14.	General operating conditions	34
Table 15.	Bluetooth Low Energy RF general characteristics	35
Table 16.	Bluetooth Low Energy RF transmitter characteristics at 1 Mbps not coded	35
Table 17.	Bluetooth Low Energy RF transmitter characteristics at 2 Mbps not coded	36
Table 18.	Bluetooth Low Energy RF transmitter characteristics at 1 Mbps LE coded (S=8)	36
Table 19.	Bluetooth Low Energy RF receiver characteristics at 1 Msym/s uncoded	37
Table 20.	Bluetooth Low Energy RF receiver characteristics at 2 Msym/s uncoded	37
Table 21.	Bluetooth Low Energy RF receiver characteristics at 1 Msym/s LE coded (S=2)	39
Table 22.	Bluetooth Low Energy RF receiver characteristics at 1 Msym/s LE coded (S=8)	39
Table 23.	Embedded reset and power control block characteristics	40
Table 24.	Current consumption	40
Table 25.	Low power mode wake-up timing	41
Table 26.	HSE crystal requirements	41
Table 27.	LSE crystal requirements	42
Table 28.	HSI oscillator characteristics	42
Table 29.	LSI oscillator characteristics	42
Table 30.	PLL characteristics	42
Table 31.	Flash memory characteristics	43
Table 32.	Flash memory endurance and data retention	43
Table 33.	ESD absolute maximum ratings	43
Table 34.	I/O static characteristics	43
Table 35.	Output voltage characteristics	44
Table 36.	RSTN pin characteristics	44
Table 37.	ADC characteristics (HSI must be set to PLL mode)	45
Table 38.	Temperature sensor characteristics	46
Table 39.	TIM2/16/17 characteristics	46
Table 40.	IWDG min./max. timeout period at 32 kHz (LSE)	46
Table 41.	I ² C analog filter characteristics	47
Table 42.	SPI characteristics	47
Table 43.	QFN32 (5 x 5 x 0.9 pitch 0.5 mm) package mechanical data	51
Table 44.	WLCSP36 (2.6525x 2.5925 x 0.4, pitch 0.4 mm) mechanical data	54
Table 45.	Package thermal characteristics	55
Table 46.	Ordering information	56
Table 47.	Document revision history	57

List of figures

Figure 1.	The BlueNRG-LPS block diagram	4
Figure 2.	Bus matrix	5
Figure 3.	BlueNRG-LPS RF block diagram	8
Figure 4.	Power supply configuration	9
Figure 5.	Power supply domain overview	9
Figure 6.	Clock tree	14
Figure 7.	Pinout top view (QFN32 package)	21
Figure 8.	Pinout bump side view (WLCSP36 package)	22
Figure 9.	Memory map	26
Figure 10.	Application circuit: DC-DC converter, WLCSP36 package	27
Figure 11.	Application circuit: DC-DC converter, QFN32 package	27
Figure 12.	Pin loading conditions	29
Figure 13.	Pin input voltage	30
Figure 14.	Recommended RSTN pin protection	45
Figure 15.	SPI timing diagram - slave mode and CPHA = 0	48
Figure 16.	SPI timing diagram - slave mode and CPHA = 1	48
Figure 17.	SPI timing diagram - master mode	49
Figure 18.	QFN32 (5x5x0.9, pitch 0.5 mm) package outline	50
Figure 19.	QFN32 (5x5x0.9, pitch 0.5 mm) package information recommended footprint	51
Figure 20.	Carrier tape QFN32 5x5 specification	52
Figure 21.	WLCSP36 (2.6525x 2.5925 x 0.4, pitch 0.4 mm) package outline (bumps view)	53
Figure 22.	WLCSP36 (2.6525x 2.5925 x 0.4, pitch 0.4 mm) recommended footprint	54
Figure 23.	Ordering information	56