

AC/DC Drivers

Quasi-Resonant Control type DC/DC Converter IC

BM1Q00XFJ Series

●General Description

The quasi-resonant controller typed AC/DC converter IC (BM1Q00XFJ series) provides an optimum system for all products that include an electrical outlet. Quasi-resonant operation enables soft switching and helps to keep EMI low. With MOSFET for switching and current detection resistors as external devices, a higher degree of design freedom is achieved. As BM1Q00XFJ series built in HV starter circuit, it contributes to low consumption power and high speed start. Because the built-in burst mode is reduced switching loss and IC consumption current is low, Stand-by power is very low. Because BM1Q00XFJ series built-in soft-start, burst mode, over current limiter which is cycle-by-cycle, over load protection, over voltage protection, CS open protection and so on, BM1Q00XFJ series are highly safety.

●Key Specifications

- Operating Power Supply Voltage Range:
 - VCC : 8.9V to 26.0V
 - VH : to 600V
- Operating Current:
 - Normal : 0.60mA (Typ.)
 - Burst : 0.35mA(Typ.)
- Max frequency: 120kHz(Typ.)
- Operate temperature range: -40°C to +105°C

●Typical Application Circuit

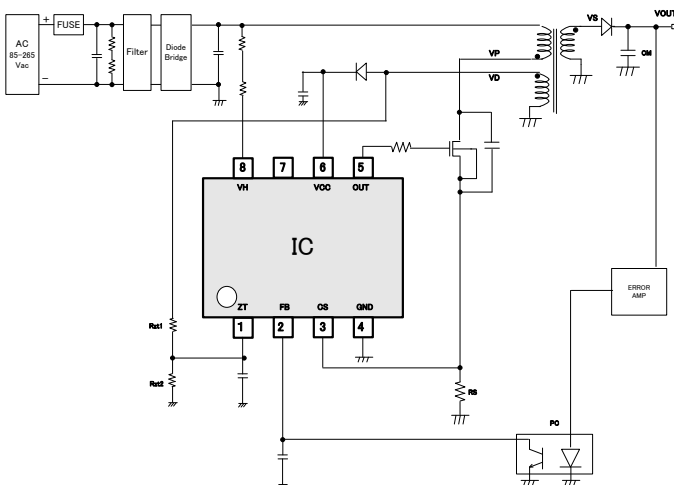

Fig 1. Application Circuit

●Features

- Quasi-resonant method
- Built-in 650V tolerate start circuit
- Low power when load is light (Burst operation)
- Maximum frequency control (120kHz)
- Frequency reduction function
- AC voltage correction function
- VCC pin : under voltage protection
- VCC pin : overvoltage protection
- Over-current protection (cycle-by-cycle)
- OUT pin : H voltage 12V clamp
- Soft start
- ZT trigger mask function
- ZT Over voltage protection
- FB Over Load protection [Auto-restart]
- CS pin open protection [Auto-restart]

●Package

SOP-J8 4.90mm × 6.00mm × 1.65mm
(Typ.) (Typ.) (Max.)



●Applications

AC adapters and household appliances (printer, TV, vacuum cleaners, air cleaners, air conditioners, IH cooking heaters etc.)

●Line Up

IC	VCC OVP	ZT OVP
BM1Q001FJ	Auto restart	None
BM1Q002FJ	Latch	Latch

●Absolute Maximum Ratings (Ta=25°C)

Item	Symbol	Rating	Unit	Condition
Input voltage range 1	Vmax1	-0.3 ~ 30	V	VCC
Input voltage range 2	Vmax2	-0.3 ~ 6.5	V	CS, FB
Input voltage range 3	Vmax3	-0.3 ~ 7.0	V	ZT
Input voltage range 4	Vmax4	-0.3 ~ 15	V	OUT
Input voltage range 5	Vmax5	-0.3 ~ 650	V	VH
OUT pin out peak current1	I _{OH}	-0.5	A	
OUT pin out peak current2	I _{OL}	1.0	A	
ZT pin current1	I _{SZT1}	-3.0	mA	
ZT pin current2	I _{SZT2}	3.0	mA	
Allowable dissipation	P _d	0.67 (Note1)	W	
Operating temperature	T _{opr}	-40 ~ +105	°C	
Max junction temperature	T _{jmax}	150	°C	
Storage temperature range	T _{str}	-55 ~ +150	°C	

(Note1) When mounted (on 70 mm x 70 mm, 1.6 mm thick, glass epoxy on single-layer substrate).

Reduce to 5.4 mW/°C when Ta = 25°C or above.

Caution: Operating the IC over the absolute maximum ratings may damage the IC. The damage can either be a short circuit between pins or an open circuit between pins and the internal circuitry. Therefore, it is important to consider circuit protection measures, such as adding a fuse, in case the IC is operated over the absolute maximum ratings.

●Operating Conditions (Ta=25°C)

Parameter	Symbol	Rating	Unit	Conditions
Power supply voltage range 1	VCC	8.9~26.0	V	VCC
Power supply voltage range 2	VH	80~600	V	VH

●Electrical Characteristics (Unless otherwise noted, Ta = 25°C, VCC = 15 V)

Parameter	Symbol	Specifications			Unit	Conditions
		MIN	TYP	MAX		
[Circuit current]						
Circuit current (ON)1	I _{ON1}	-	600	1000	uA	FB=2.0V (Switching operation)
Circuit current (ON)2	I _{ON2}	-	350	450	uA	FB=0.5V (Switching OFF)
Circuit current(OFF)	I _{OFF}	-	-	25	uA	VCC=12V, VH:open VCC UVLO = disable
[VH pin starter]						
VH Start current1	I _{START1}	0.400	0.700	1.000	mA	VCC= 0V
VH Start current2	I _{START2}	1.00	3.00	6.00	mA	VCC=10V
VH OFF current	I _{START3}	-	10	20	uA	Released VCCUVLO VH pin current
VH start current switched voltage	V _{SC}	0.400	0.800	1.400	V	VCC pin
[VCC pin protection]						
VCC UVLO voltage1	V _{UVLO1}	12.50	13.50	14.50	V	VCC rise
VCC UVLO voltage2	V _{UVLO2}	7.50	8.20	8.90	V	VCC fall
VCC UVLO hysteresis	V _{UVLO3}	-	5.30	-	V	V _{UVLO3} = V _{UVLO1} -V _{UVLO2}
VCC charge start voltage	V _{CHG1}	7.70	8.70	9.70	V	Starter circuit
VCC charge end voltage	V _{CHG2}	12.00	13.00	14.00	V	Stop voltage from V _{CHG1}
VCC OVP voltage1	V _{OV1}	26.00	27.50	29.00	V	VCC rise
VCC OVP voltage2	V _{OV2}	-	23.50	-	V	VCC fall [BM1Q001]
VCC OVP hysteresis	V _{OV3}	-	4.00	-	V	[BM1Q001]
[OUT pin]						
OUT pin H voltage	V _{OUTH}	10.5	12.5	14.5	V	I _O =-20mA, VCC=15V
OUT pin L voltage	V _{OUTL}	-	-	0.30	V	I _O =+20mA
OUT pin Pull-down resistor	R _{PDOUT}	75	100	125	kΩ	

● IC control unit Electrical Characteristics (Unless otherwise noted, Ta = 25°C, VCC = 15 V)

Parameter	Symbol	Specifications			Unit	Conditions
		MIN	TYP	MAX		
[DC/DC converter unit (Turn-off)]						
Pull-up resistor of FB pin	R _{FB}	22.5	30.0	37.5	kΩ	
CS over current voltage 1A	V _{lim1A}	0.475	0.500	0.525	V	FB=2.2V (ACSNS=L)
CS over current voltage 1B	V _{lim1B}	0.310	0.350	0.390	V	FB=2.2V (ACSNS=H)
CS over current voltage 2A	V _{lim2A}	0.100	0.125	0.150	V	FB=0.5V (ACSNS=L)
CS over current voltage 2B	V _{lim2B}	0.062	0.088	0.113	V	FB=0.5V (ACSNS=H)
Voltage gain1 (ΔVFB/ΔVCS)	AV _{CS1}	3.40	4.00	4.60	V/V	ACSNS=L
Voltage gain 2 (ΔVFB/ΔVCS)	AV _{CS2}	4.86	5.71	6.57	V/V	ACSNS=H
ZT current switched CS 1	I _{ZT1}	0.93	1.00	1.07	mA	
ZT current switched CS 2	I _{ZT2}	0.82	0.90	0.98	mA	
ZT current hysteresis switched CS voltage	I _{ZTHYS}	-	0.10	-	mA	
CS Leading Edge Blanking	T _{LEB}	-	0.250	-	us	
Turn-off time	T _{OFF}	-	0.150	-	us	At applying PULSE to the CS pin
Minimum ON width	T _{min}	-	0.400	-	us	T _{LEB} + T _{OFF}
Maximum ON width	T _{max}	30.0	39.0	50.7	us	
[DC/DC converter unit (Turn-on)]						
ZT input current 1	I _{ZT1}	4	14	24	uA	OUT=L, ZT=4.65V
ZT input current 2	I _{ZT2}	6	16	26	uA	OUT=L, ZT=5.00V
ZT input current 3	I _{ZT3}	8	18	28	uA	OUT=L, ZT=5.35V
Max frequency 1	F _{SW1}	108	120	132	kHz	FB=2.0V
Max frequency 2	F _{SW2}	21	30	39	kHz	FB=0.5V
Frequency reduction start voltage	V _{FBSW1}	1.10	1.25	1.40	V	
Frequency reduction end voltage	V _{FBSW2}	0.42	0.50	0.58	V	
ZT comparator voltage1	V _{ZT1}	60	100	140	mV	ZT fall
ZT comparator voltage2	V _{ZT2}	120	200	280	mV	ZT rise
ZT trigger mask time	T _{ZTMASK}	-	0.6	-	us	In OUT H → L, prevent noise
ZT trigger Timeout1	T _{ZTOUT1}	10.5	15.0	19.5	us	No bottom detection
ZT trigger Timeout2	T _{ZTOUT2}	3.5	5.0	6.5	us	From final ZT trigger
[DC/DC protection]						
Soft start time1	T _{SS1}	0.35	0.50	0.65	ms	
Soft start time 2	T _{SS2}	0.70	1.00	1.30	ms	
Soft start time 3	T _{SS3}	1.40	2.00	2.60	ms	
Soft start time 4	T _{SS4}	2.80	4.00	5.20	ms	
FB Burst voltage	V _{BURST}	0.42	0.50	0.58	V	Burst ON
FB OLP voltage a	V _{FOLP1A}	2.6	2.8	3.0	V	FBOLP detect (FB rise)
FB OLP voltage b	V _{FOLP1B}	-	2.6	-	V	FBOLP detect (FB fall)
FB OLP delay timer	T _{FOLP}	44.8	64	83.2	ms	
FBOLP stop timer	T _{OLPST}	358	512	666	ms	
Latch released voltage (VCC pin voltage)	V _{LATCH}	-	V _{UVLO2} - 0.50	-	V	
Latch mask time	T _{LATCH}	50	100	200	us	
ZT OVP voltage	V _{ZTL}	4.65	5.00	5.35	V	[BM1Q002FJ]

* Definition of ACSNS (L : ZT current < I_{ZT1} 、 H : ZT current > I_{ZT1})

● Pin Configuration

Table 1 Input-Output PIN Function

NO.	Pin Name	I/O	Function	ESD Diode	
				VCC	GND
1	ZT	I	Zero current detect pin	-	○
2	FB	I	Feedback signal input pin	○	○
3	CS	I	Primary current sensing pin	○	○
4	GND	I/O	GND pin	○	-
5	OUT	O	External MOS drive pin	○	○
6	VCC	I/O	Power supply pin	-	○
7	N.C.	-	Non Connection	-	-
8	VH	I	Starter circuit pin	-	○

● External Dimensions

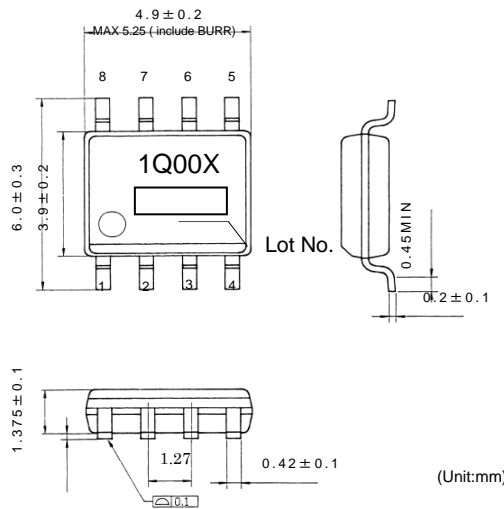

Fig-2 External Dimensions

● I/O Equivalent Circuit Diagram

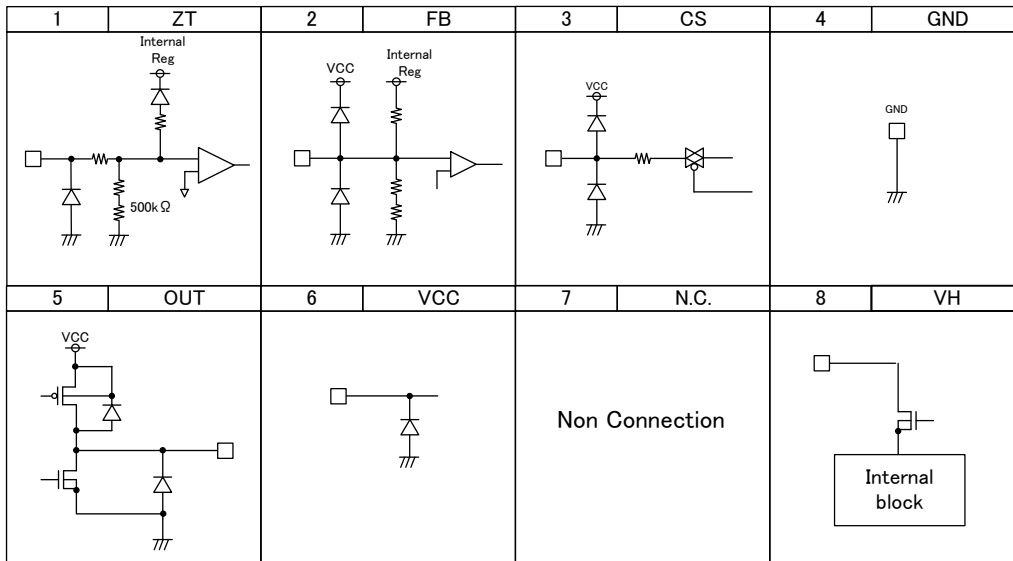

Fig-3 I/O Equivalent Circuit Diagram

● Block Diagram

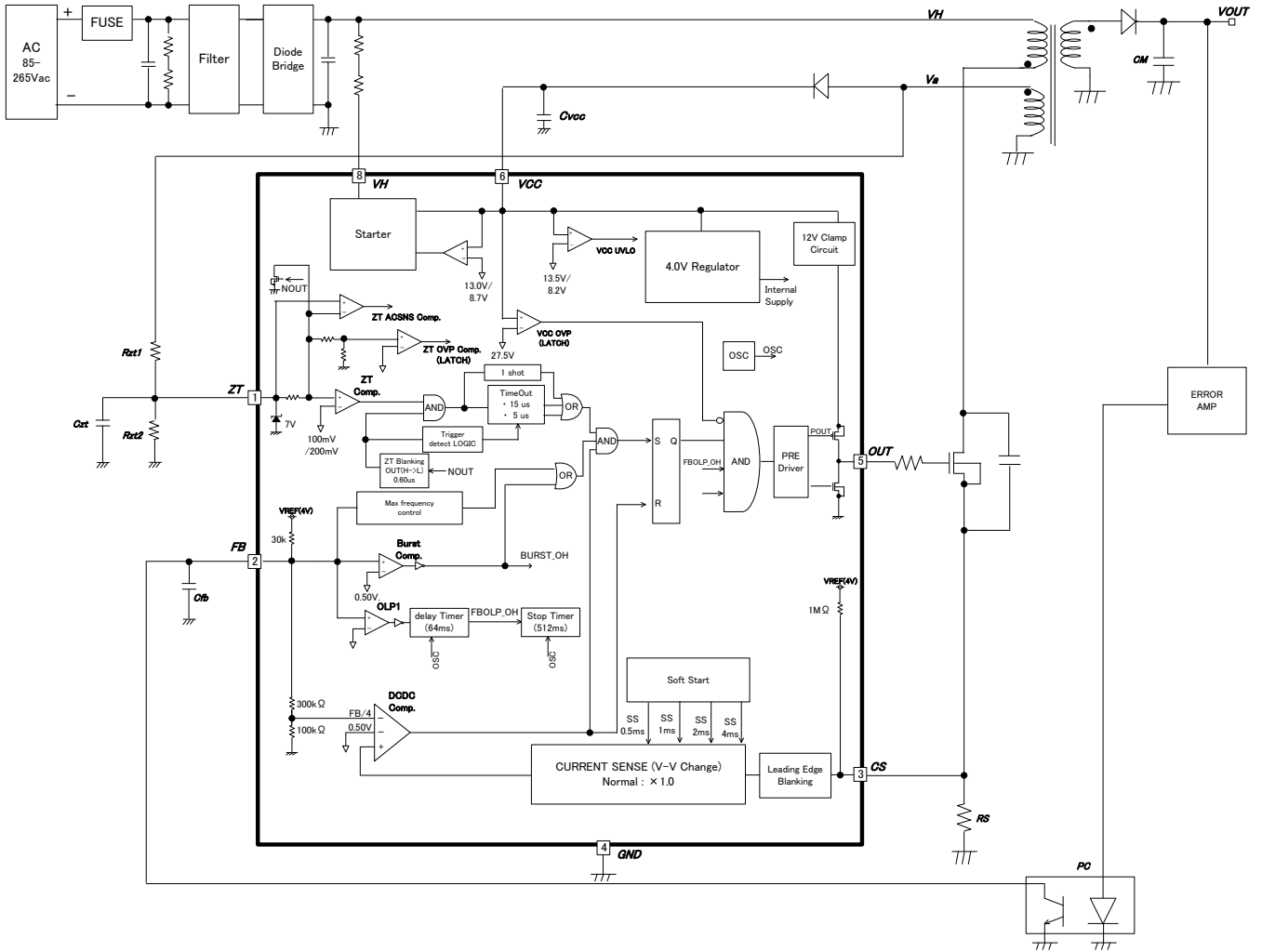

Fig-4 Block Diagram

●Description of Blocks

(1-1) Starter Circuit VH pin(8pin)

IC builds in starter circuit (tolerates 650V) to VH pin (8pin). It enables to be low standby power and high speed starting. The operating current is shown in Fig-6. After starting IC, consumption power is decided by multiplied idling current I_{START3} (typ=10uA) with VH voltage. The loss by the idling current is below.

- ex) power consumption of starter circuit only
 $V_{ac}=100V$ $Power=100V \cdot \sqrt{2} \cdot 10\mu A=1.41mW$
 $V_{ac}=240V$ $Power=240V \cdot \sqrt{2} \cdot 10\mu A=3.38mW$

Start time is decided by VH current and VCC pin capacitor.
 The reference value of start time is shown in Fig7. For example, VCC capacitor is charged within 0.1s in C_{VCC}=10uF
 When VCC pin is shorted to GND, current of "I_{START1}" flows. (Fig-6)
 When VH pin is shorted to GND, large current flows from VH line to GND. To prevent it, need to insert resistor (5kΩ ~60kΩ) of "R_{VH}" to limit current between VH line and VH pin.
 When VH pin is shorted to GND, the power of VH^2/R_{VH} is applied. For that, please decide resistor size to confirm power dissipation. When it does not satisfy power dissipation by one resistor, please use more than two resistors.

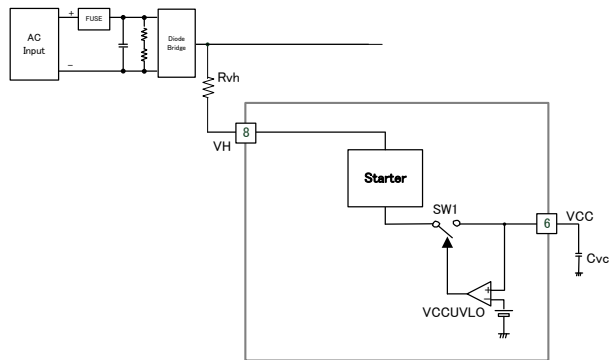

Fig-5 Starter Block Diagram

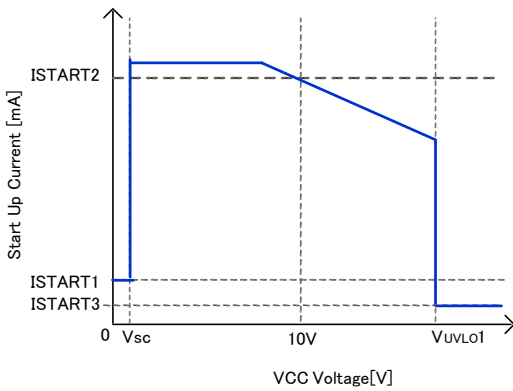

Fig-6 Start-up Current vs VCC Voltage
 *The start up current is flown from VH pin(8Pin).

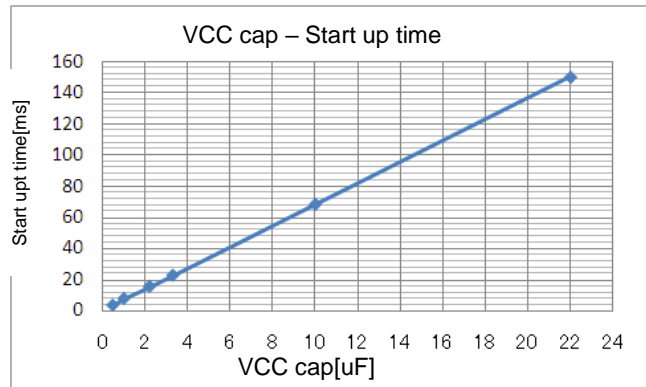

Fig-7 Start-up Time (example)

It shows operation waveform of start-up in Fig-8.

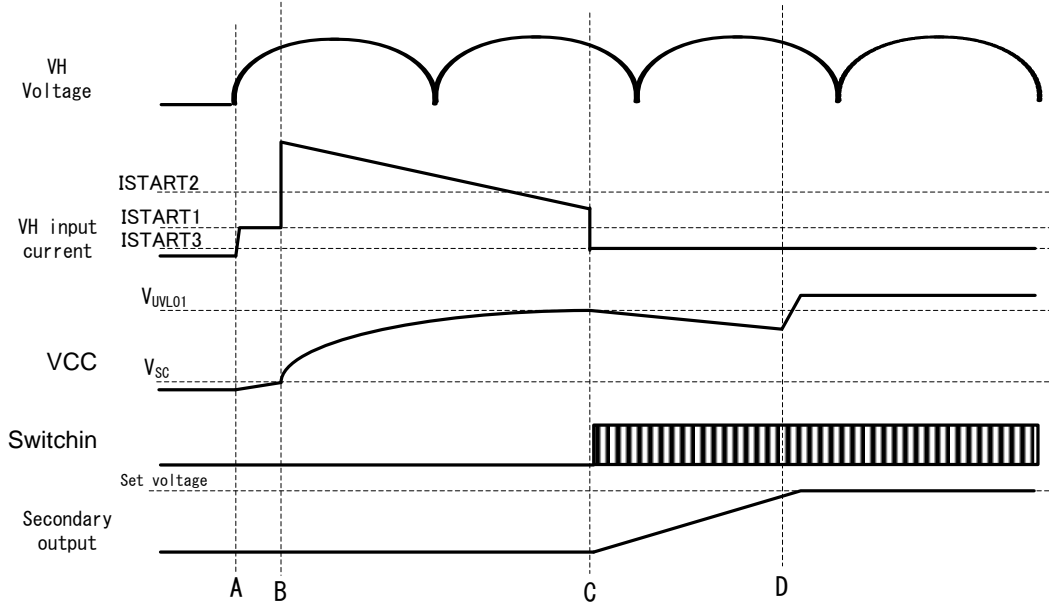

Fig-8 Start-up Waveform

- A: By inserting to outlet, VH voltage applies. From the time, charging to VCC pin starts from VH pin through starter circuit. At the time, due to $VCC < V_{sc}$ (typ=0.8V), VH input current is limited to ISTART1 by VCC pin short protection.
- B: Because of $VCC \text{ voltage} > V_{sc}$ (typ=0.8V), VCC short protection is released, the current flows from VH pin.
- C: Because of $VCC \text{ voltage} > V_{UVLO1}$ (typ=13.5V), the start-up stops, and VH input current is limited to ISTART3 (typ=10uA). Furthermore, because switching operation starts, Secondary output rises. However, because Secondary output is low, VCC pin voltage is decreased. The falling rate of VCC is determined by VCC pin capacitance, the consumption current of IC and the load current that flows from the VCC pin. ($V/t = C_{vcc}/I_{cc}$)
- D: Because secondary output has risen to specific voltage, VCC pin voltage is applied from the auxiliary winding and VCC voltage is stabilized.

(1-2) In Case of Useless VH pin (8pin)

This IC is also possible to start by connecting the start-up resistor to the VCC pin in the open the start-up circuit (650V breakdown voltage) of the VH pin. The structure that do not use the recharge function is shown in Fig- 9. At start-up (before VCC VULO releasing) , please be careful to set the start-up resistor shown in blue because the consumption current I_{OFF} (Max=25uA) flows from VCC pin(6pin). Also, in case of not to use recharge function, the same circuit is used.

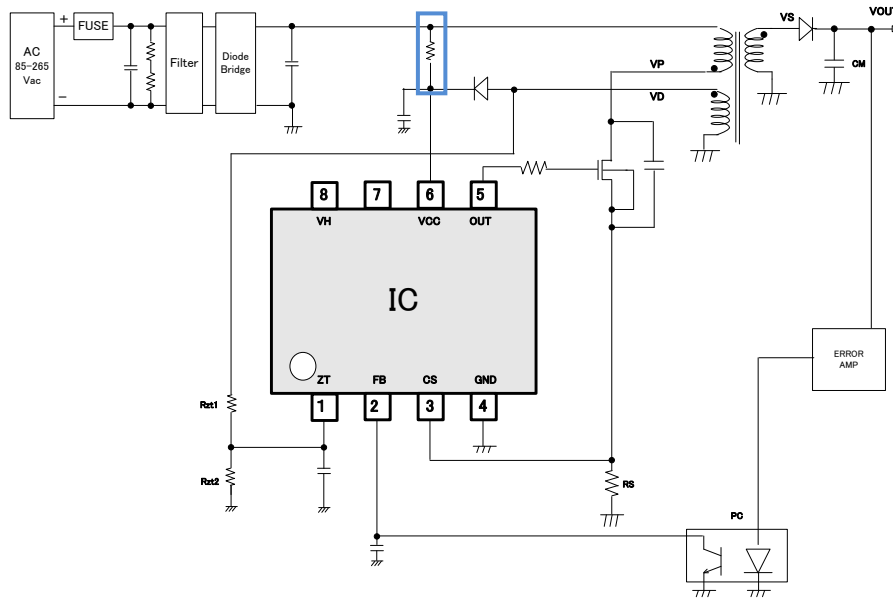

Fig-9 Application Circuit not to use VH Pin (8pin)

•How to set the start-up resistance

Start-up resistor R_{start} shown in Fig-9 in blue, is necessary for the IC to start if you do not use the VH pin. If you reduce R_{start} value, standby power is increased, start-up time is shorter. If you increase R_{start} on the contrary, standby power is reduced, start-up time will be longer. When the voltage $V_{CC}=12V$, standby current I_{OFF} is 25uA (max), V_{CC} UVLO voltage V_{UVLO1} is 14.5V (max).

ex) The example of start-up resistor R_{start} setting

$$R_{start} = (V_{min} - V_{UVLO1}(\max)) / I_{OFF}(\max)$$

In $V_{ac}=100V$, if margin is -30% , $V_{Hmin}=100 \times \sqrt{2} \times 0.7=99V$
 $V_{UVLO1}(\max)=14.5V$,so
 $R_{start} = (99-14.5) / 25\mu A=3.38M\Omega$

For an example, with a sufficient margin to 3.38MΩ, and the R_{start} is 2.0MΩ..

For AC100V, Power consumption in R_{start} is below.

$$P_d (R_{start}) = (V_H - V_{CC})^2 / R_{start} = (141V - 14.5V)^2 / 2.0M = 8.00mW$$

P_d in using start-up resistor is more than in using VH pin,

However for VCC pin capacitance value and VCC start-up resistor, please confirm by performing the evaluation of the actual application.

(2) Start Sequence (Soft start, Light load operation, Auto recovery in over load protection)

The start sequence of IC is shown in Fig-10. About each detail, explain in each section.

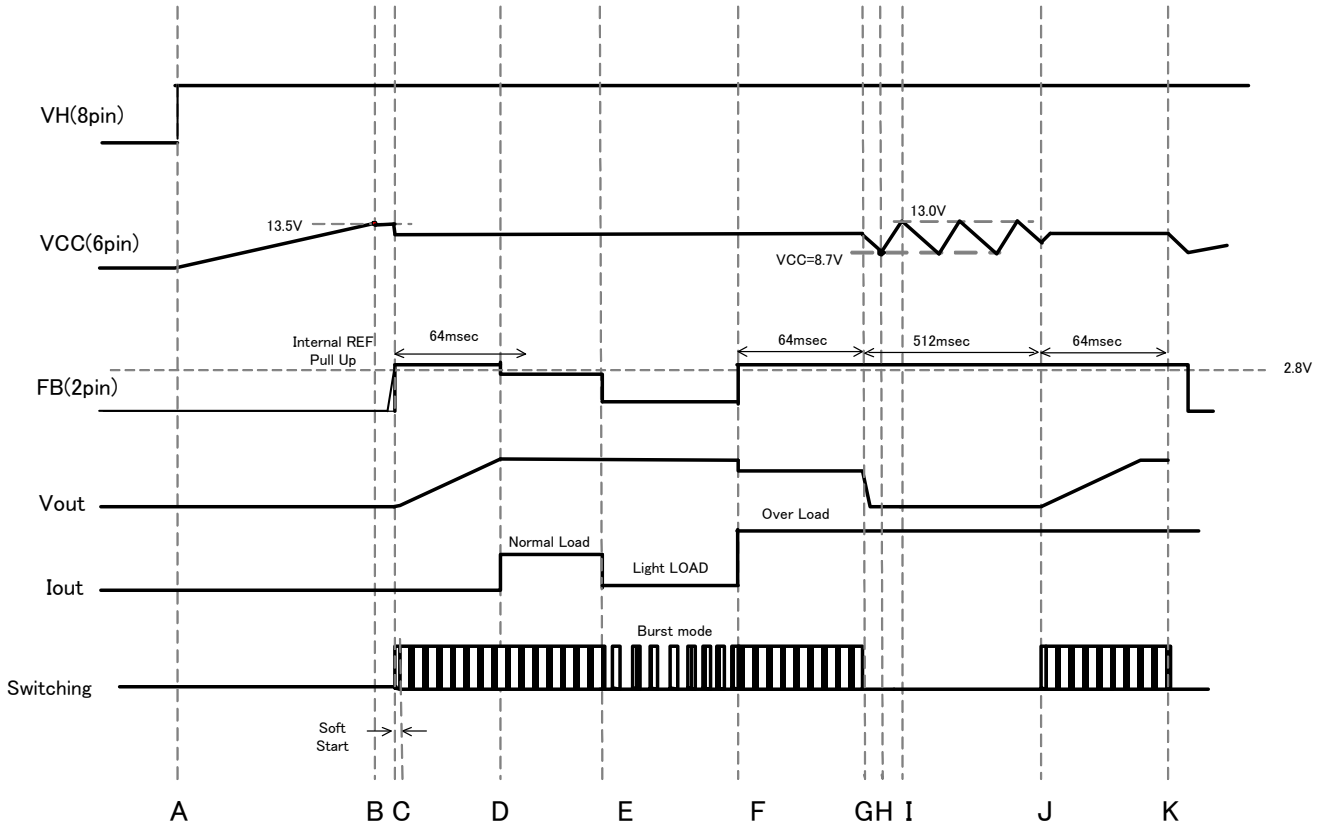

Fig-10 Start Sequence Time Chart

- A: Input voltage from AC line is supplied to VH pin(8Pin).
- B : VCC pin(6pin) voltage is rise, when $V_{CC} > V_{UVLO1}$ (typ=13.5V), IC starts operating.
 In case of protection function is no active, IC starts to switching operation.
 Then VCC pin voltage is dropped in cause of VCC (6pin) consumption current.
 In case of $V_{CC} < V_{CHG1}$ (typ=8.7V), starter circuit is operated, IC starts to charge VCC pin. After starting of charge, IC continues to charge until $V_{CC} > V_{CHG2}$ (typ=13.0V).
- C: There is a soft start function which regulates the voltage level at the CS pin to prevent a rise in voltage and current.
- D: When the switching operation starts, VOUT rises.
 Once the output voltage starts-up, set to stable the output voltage to within the T_{FOLP} (typ=64ms) period
- E: When it is light load, burst operation is used to keep power consumption down.
- F: When it is heavy load, FB pin voltage (2pin) is larger than V_{FOLP1A} (typ=2.8V), because output voltage is down.
- G: When the FB pin(2pin) voltage keeps V_{FOLP1A} (typ=2.8V) at or above T_{FOLP} (64ms typ), switching is stopped by the over load protection for T_{OLPST} (typ=512ms).
 When the FB pin(2pin) voltage does not keep V_{FOLP1B} (typ=2.6V) at T_{FOLP} (64ms typ), the timer of T_{FOLP} (typ=64ms) is reset.
- H : When VCC pin(6pin) voltage is V_{CHG1} (typ=8.7V) or less, starter circuit starts to charge VCC pin(6pin) to operate starter circuit.
- I : When VCC pin(6pin) voltage is over than V_{CHG2} (typ =13.0V), starter circuit stops to charge VCC pin(6pin).
- J: The same as F.
- K: The same as G.

(3) VCC pin(6pin) Protection Function

IC built in VCC UVLO(Under Voltage Lock Out) function and VCC OVP (Over Voltage Protection) function and VCC charge function.

VCC UVLO function is the protection for VCC (pin) voltage is low. VCC OVP function is the protection for VCC (6pin) voltage is high. They are for preventing MOSFET from destroying for switching in VCC voltage low or high.

VCC charge function is stable for output voltage in VCC pin voltage low, because starter circuit charge VCC pin from VH line.

(3-1) VCC UVLO / VCC OVP Function

VCCUVLO is an auto recovery type that has voltage hysteresis. VCCOVP is able to select an auto recovery type (BM1Q001FJ) and VCCOVP is a latch type (BM1Q002FJ).

$VCC < V_{LATCH}$ (typ=7.7V) is condition of latch release (reset) after detection of latch operation by VCCOVP.

Refer to the operation figure-11.

VCCOVP built in mask time for T_{LATCH} (typ=100us). This function operates to successful detection at VCC pin voltage $> V_{OVP1}$ (typ=27.5V). By this mask time, this IC masks surge etc.

In case of BM1Q001FJ (Auto recovery), When IC detects VCCOVP function, IC stops switching until VCC pin voltage is smaller than V_{OVP2} (typ=23.5V).

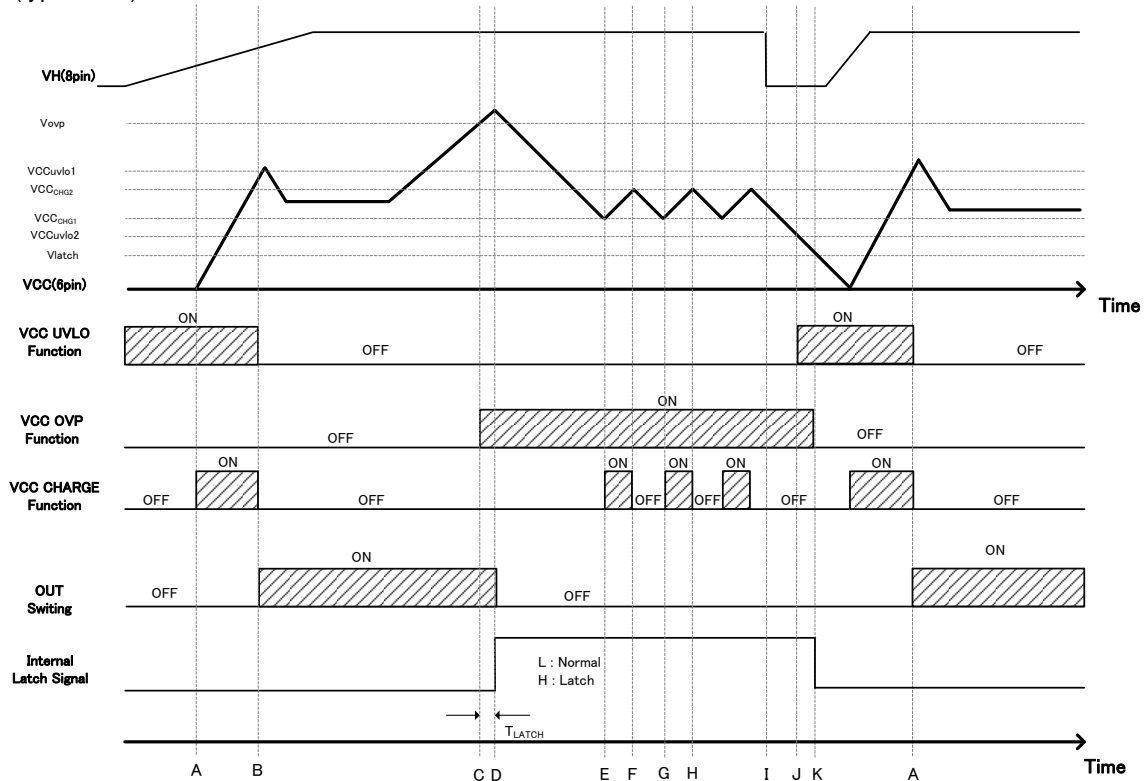

Fig-11 VCC UVLO / OVP Timing Chart(In case of BM1Q002FJ)

- A: VH (8pin) voltage input, VCC (6pin) voltage starts rising.
- B: VCC pin voltage $> V_{UVLO1}$, releases the VCC UVLO function and DC/DC operation starts.
- C: VCC pin voltage $> V_{OVP1}$, VCCOVP detects the over-voltage.
- D: When the VCC (6pin) voltage $> V_{OVP1}$ continues T_{LATCH} (typ =100us), switching is stopped by the VCCOVP function. (LATCH mode)
- E: VCC (6pin) voltage $< V_{CHG1}$, VCC charge function operates and the VCC pin (6pin) voltage rises.
- F: VCC (6pin) voltage $> V_{CHG2}$, VCC charge function stops.
- G: The same as E.
- H: The same as F.
- I: VH line voltage is down.
- J: $VCC < V_{UVLO2}$, VCC UVLO function starts to operate.
- K: $VCC < V_{LATCH}$, latch function is released.

•For Capacitor Value of VCC pin

For stable operation of the IC, please set the 1uF or higher capacitor value of VCC pin. When the VCC capacitor terminal is too large, response of the VCC pin to the Secondary output is slows down. Please be careful. If the degree of the transformer coupling is low, since a large surge occurs to the VCC pin, the IC may be destroyed. In this case, please attach a resistor which is from 10Ω to 100Ω to the path between the capacitor and diode at the back of the auxiliary winding. Please set the resistance value in order that surge of VCC pin does not exceed the absolute maximum rating of the VCC pin by performing the waveform evaluation of VCC pin.

•For settings VCC OVP voltage protection when Vout (Secondary output) is increased

VCC pin voltage is determined by the transformer ratio and Vout (Secondary output). Therefore, when the Secondary output is large, it is possible to protect IC by VCCOVP. Setting VCCOVP protection is below.

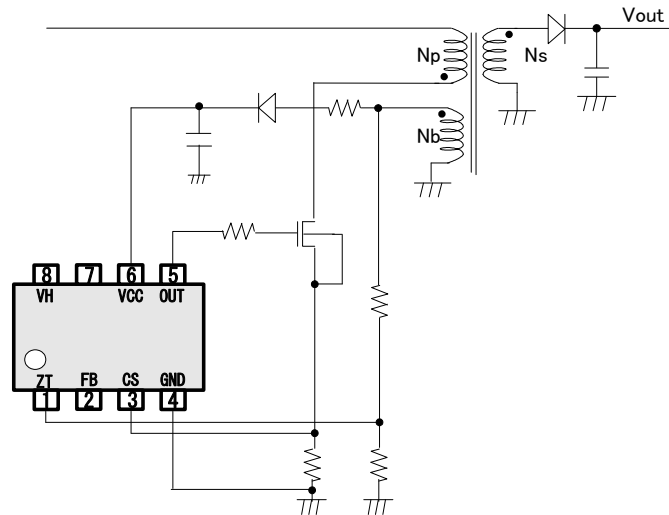

Fig-12 How to Set VCCOVP

$VCC \text{ voltage} = Vout \times Nb / Ns - VF$ (Vout:Secondary output, Nb:Number of auxiliary winding, Ns:Number of secondary winding)

If you wish to apply protection when it becomes Secondary output $\times 1.3$, please set the number of turns so that $1.3 \times (Vout \times (Nb / Ns) - VF) > VOVP1$

Because there is a blanking time of T_{LATCH} (typ = 100us) to VCCOVP protection, VCCOVP protection is not detected to momentary surge noise of the VCC pin, However, VCCOVP is detected when VCC voltage is higher than the $VOVP1$ at the period of more than T_{LATCH} , due to low degree of transformer coupling or other influences

In addition, as a protection of Secondary output, ZTOVP is also available. ZTOVP is described in (6).

(3-2)VCC Recharge Function

After VCC (6pin) voltage > V_{UVLO1} , IC start to operate. After that, when VCC pin voltage < V_{CHG1} , VCC charge function is active. Then starter circuit operates charge VCC (6pin) from VH line. By these, it does not occur start problem. When the IC charge the VCC pin (6pin) and the VCC pin voltage exceeds V_{CHG2} , the charging function is finished.

The operation is shown to Figure-13.

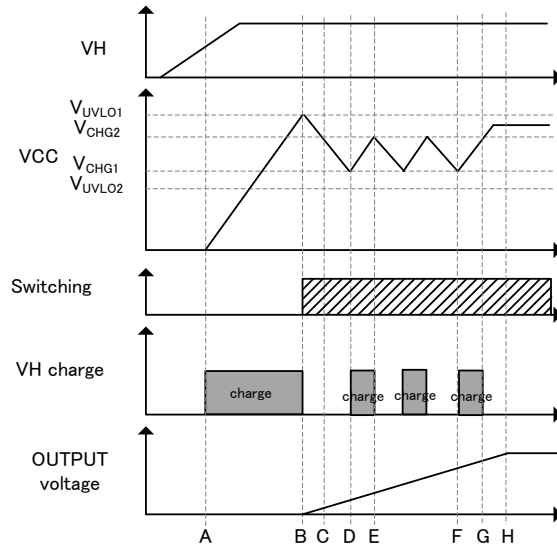

Fig-13 VCC pin Charge Operation

- A :As VH pin voltage(8pin)is rising, VCC pin(6pin) is started to charge by VCC charge function.
- B: VCC pin (6pin) voltage > V_{UVLO1} , VCC UVLO function is released, VCC charge function is stopped, DC/DC operation start.
- C: VCC pin (6pin) voltage is dropped for starting operation because OUTPUT voltage is low.
- D: VCC pin (6pin) voltage < V_{CHG1} , VCC pin(6pin) voltage rises to operate charge function.
- E: VCC pin (6pin) voltage > V_{CHG2} , VCC charge function stops.
- F: VCC pin (6pin) voltage < V_{CHG1} , VCC pin (6pin) voltage rises to re-operate charge function.
- G: VCC pin (6pin) voltage > V_{CHG2} , VCC charge function stops.
- H: OUTPUT voltage is stable. Then, VCC pin (6pin) voltage is also stable for charging from the auxiliary winding to VCC pin(6pin).

(4) DC/DC Driver

The IC operates PFM (Pulse Frequency Modulation) mode method.

By monitoring FB pin(2pin) and ZT pin (1pin), CS pin(3pin), the IC supply optimum system for DC/DC operation.

The IC controls ON width (Turn Off) of external MOSFET by FB pin (2pin) and CS pin (3pin). The IC controls OFF width (Turn ON) of external MOSFET by ZT pin (1pin). The detail is shown below.

(4-1) For QR-basic Operations

The QR basic block diagram and the basic operation are shown in Fig-14,15.

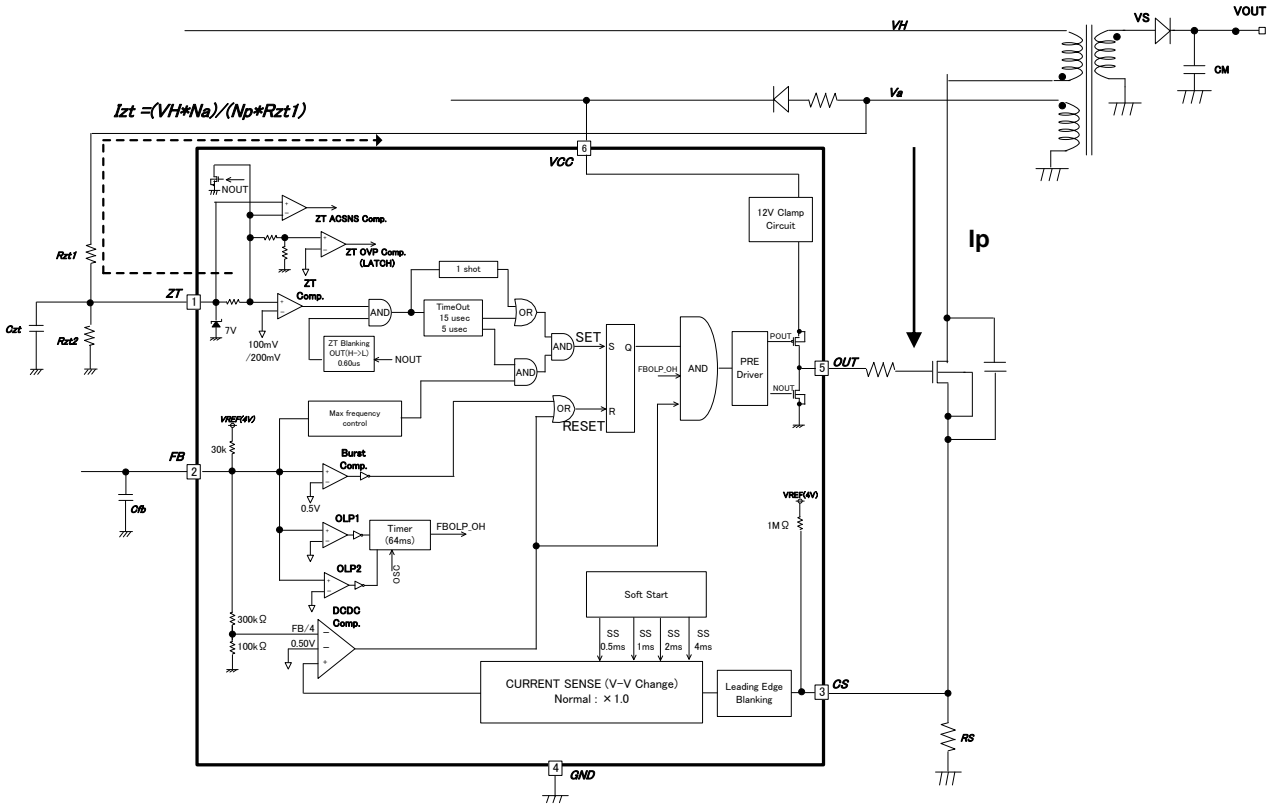

Fig-14 DC/DC Operation Block

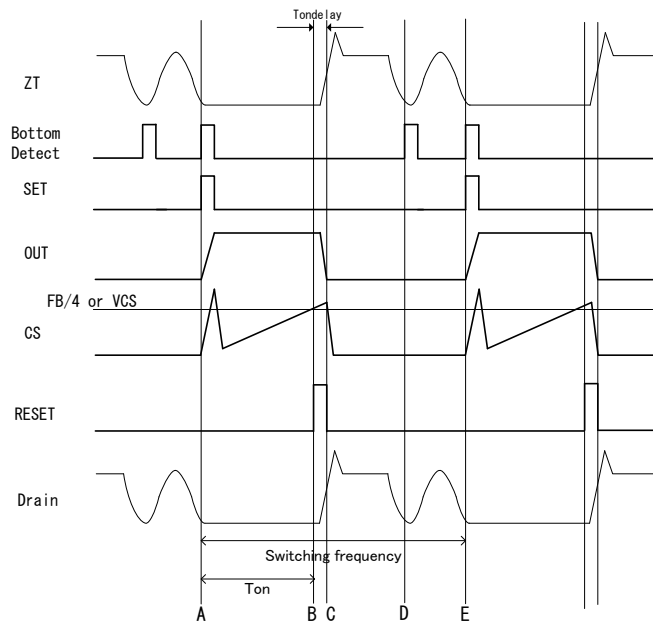

Fig-15 QR Basic Operation

For Fig-15

- A: The internal oscillator outputs the SET signal, and turns ON the MOSFET.
 At this time, the Drain - source capacitance of the MOSFET is discharged, so noise is generated to the CS pin.
 This noise is called Leading Edge.
 The filter for this noise is built in this IC. (It refer to (4-3))
 Minimum pulse width of the IC is a 400ns (typ) by this filter and the delay time.
 After that, current flows through the MOSFET, and Voltage $V_{cs} = R_s * I_p$ is applied to the CS pin.
- B: When CS pin voltage rises than FB pin voltage/Gain (typ = 4) or the overcurrent detection voltage V_{cs} , RESET signal is output, OUT turns OFF
- C: There is a delay time $T_{ondelay}$ from the point of B to turn OFF actually. Because of Tondelay the difference occurs in the maximum power by the AC voltage. This IC has a built-in function to reduce this difference. (It refer to (4-4))
- D: The energy stored in the transformer during T_{on} is discharged to the secondary side, and Free vibration of the Drain voltage caused by the C_{ds} (Drain - source capacitance) of MOSFET and L_p (transformer value) begins.
- E: Since the switching frequency is determined by the IC.
 SET signal is output from the internal oscillator and turn ON the MOSFET by process of certain time from A.

(4 -2) Determination of ON Width (Turn OFF)

ON width is controlled by FB (2pin), CS (3pin).
 By comparison between FB pin voltage divided by A_{Vcs} (typ=4) and CS pin voltage, the IC decides ON width.
 Besides, by comparison with V_{lim1} (typ =0.5V) voltage which is generated in IC, CS comparator level is changed lineally to be shown in Fig-16(bottom). Maximum frequency also changes at this time.
 CS (3pin) is shared with over current limiter circuit by pulse.
 IC is changed over current limiter level and max frequency by FB (2pin) voltage.

- mode1 : Burst operation
- mode2 : Frequency reduction operation (reduce max frequency)
- mode3 : Max frequency operation (120kHz)
- mode4 : Over load operation (To detect over load state, IC is stopped switching)

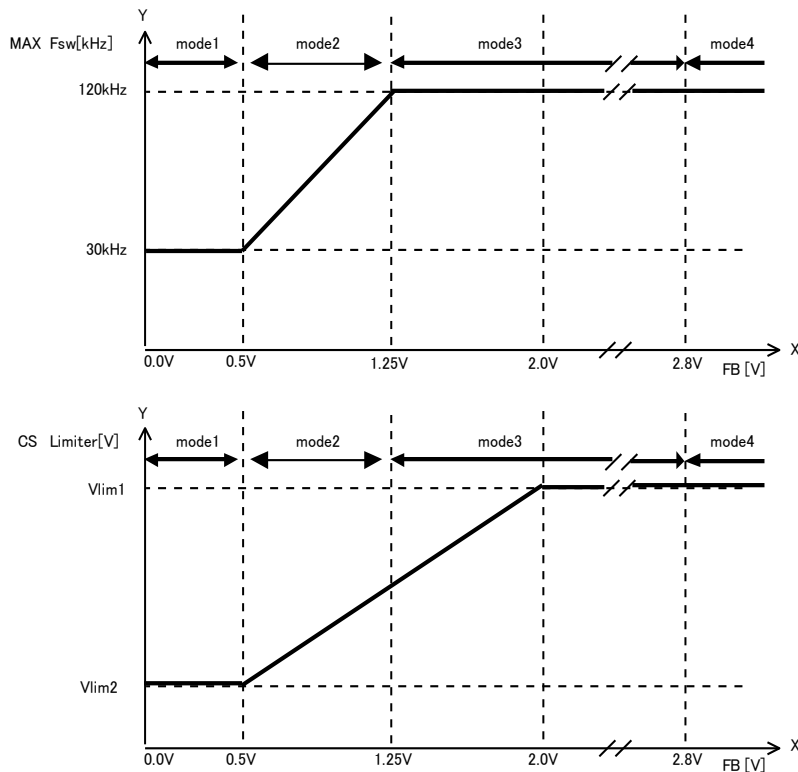

Fig-16 FB pin Voltage - Over Current Limiter, Max Frequency Characteristics

The ON width of "Ton" is decided by CS Limiter level "VCS"

$$T_{on} = (L_p \cdot V_{cs}) / (V_{in} \cdot R_s)$$

L_p: primary inductance value, V_{in} :VH voltage in Fig-14, R_s: Sense resistor in Fig-14

To adjust over current limiter level, CS over current protection voltage is switched in soft-start, AC voltage. Vlim1 and Vlim2 is changed below.

Table2 Over current protection voltage Detail

Soft start	AC=100V		AC=230V	
	Vlim1	Vlim2	Vlim1	Vlim2
start~0.5ms	0.063V (12%)	0.016V (3%)	0.044V (10%)	0.011V (2%)
0.5ms~1ms	0.125V (25%)	0.032V (6%)	0.088V (20%)	0.022V (4%)
1ms~2ms	0.250V (50%)	0.063V (12%)	0.175V (40%)	0.044V (9%)
2ms~4ms	0.375V (75%)	0.094V (19%)	0.263V (60%)	0.066V (13%)
4ms~	0.500V (100%)	0.125V (25%)	0.350V (70%)	0.087V (18%)

* (percent) is shown comparative value with Vlim1 (typ =0.5V) in normal operation.

The reason that distinguish between AC100V and AC230V is by CS over current protection voltage switch function which is shown to (4-4).

(4-3) LEB(Leading Edge Blanking) Function

When a MOSFET for switching is turned ON, surge current occurs in cause of capacitance or rush current. Therefore, when CS (3pin) voltage rises temporarily, over current limiter circuit may miss detections. To prevent miss detections, the IC build-in blanking function which mask for T_{LEB} (typ=250ns) from switching OUT pin(5pin) from L to H. This blanking function enables to reduce noise filter of CS pin(3pin). However, when CS pin noise does not converge less than 250ns, need to attach RC filter to CS pin shown in Fig-17. Then, delay time occurs to CS pin detection by RC filter. Also, even if the filter in not attached, it is recommended that it is attached an Rcs resistor to CS pin as surge provision. Rcs recommended resistor value is about 1kΩ.

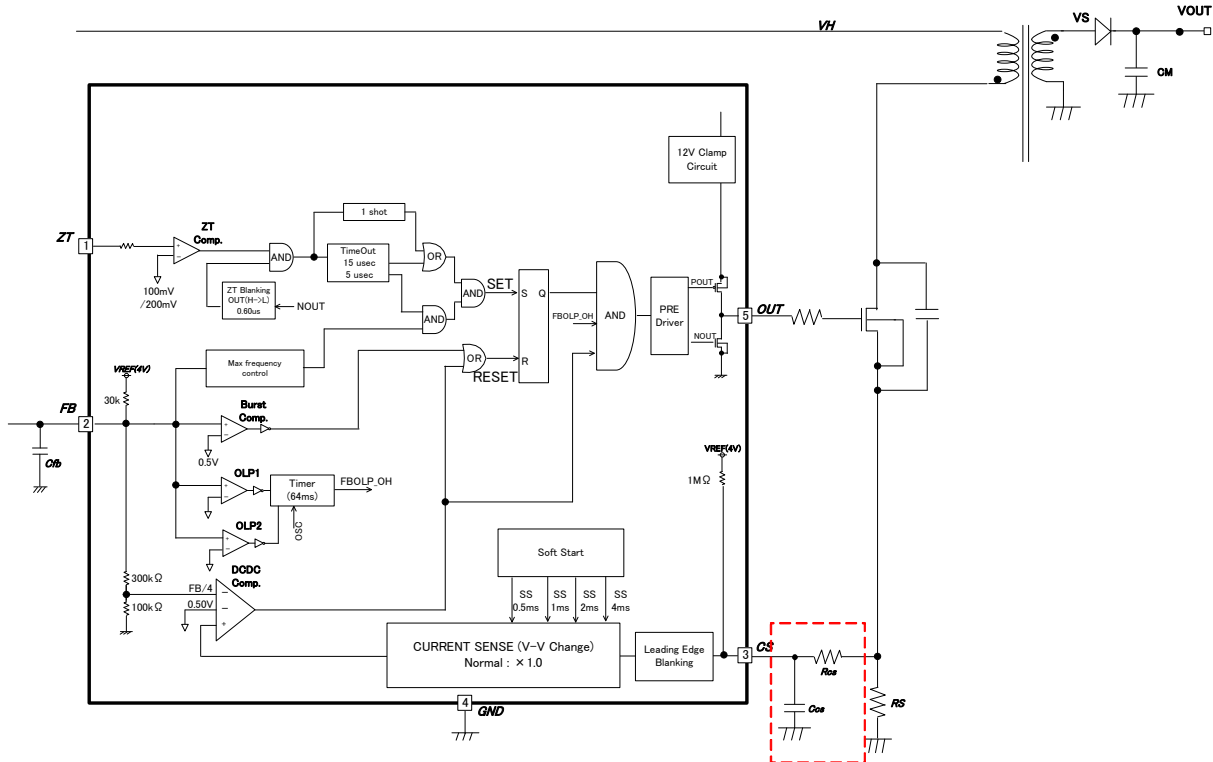

Fig-17. CS pin surrounding circuit

(4-4) CS Over Current Protection Switching Function

When input voltage (VH) is higher, ON time is short, and the operating frequency increases. As a result, maximum capable power increases for constant over current limiter. For that, monitoring input voltage (VH), IC switches over current detection of IC.

In case of high voltage (AC230V), IC changes over current comparator level to x0.7 multiple of normal level.

The detection method is that IC monitors ZT input current, then, IC switches it. When MOSFET turns on, the voltage of "Va" has negative voltage to be affected input voltage (VH). Then, ZT (1pin) voltage is clamped near 0V by IC, ZT pin flows current to bias coil. The calculation is below. And show block figure to Fig-18, show graph to Fig-19, Fig-20.

$$I_{zt} = (V_a - V_{zt}) / R_{zt1} \approx V_a / R_{zt1} = V_H * N_a / N_p / R_{zt1}$$

$$R_{zt1} = V_a / I_{zt}$$

Please set ZT current "Izt" to select the resistor Rzt1. And set bottom detection timing to select Czt. About ZT current, IC builds in ZT current hysteresis IztHYS(typ=0.1mA) to prevent VH detection changing by input voltage.

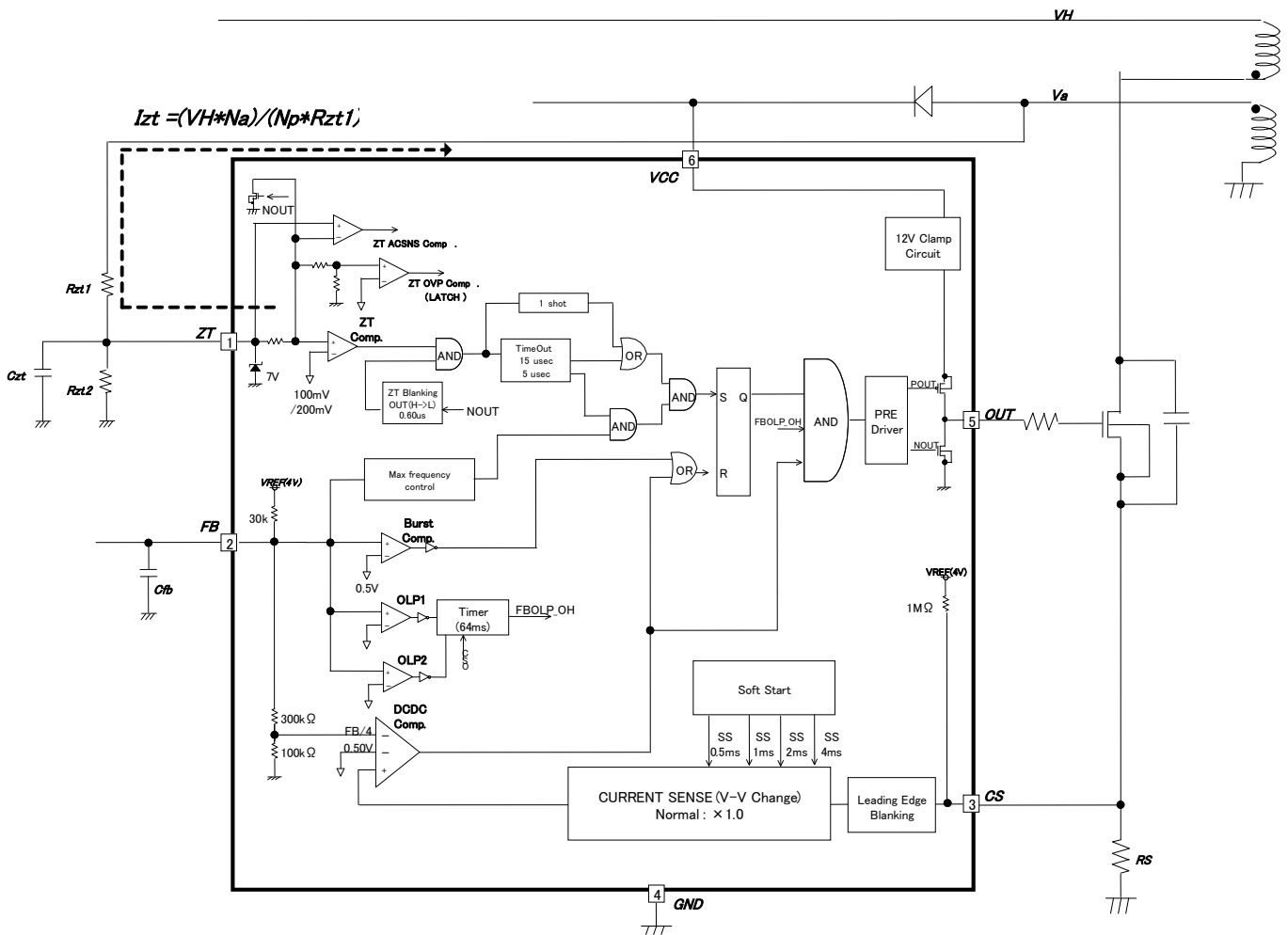

Fig-18 CS Over Current Detection Switched ZT current block diagram

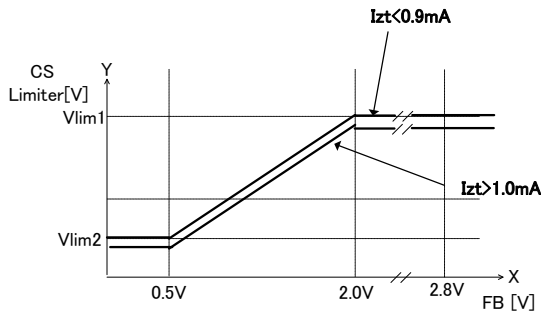

Fig-19 FB pin Voltage vs CS pin Voltage Characteristics

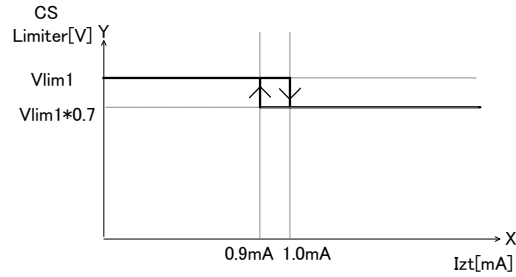

Fig-20 Izt Current vs Switched CS Voltage Characteristics

ex) setting method (Switching between AC100V and AC220V)

AC100V: 141V±28V(±20% margin)

AC220V: 308V±62V(±20% margin)

In above case, need to switch CS over current detection voltage from 169V to 246V.

For that, switching VH voltage from AC100V to AC220V may be selected in VH=214V.

Setting Np=100, Na=15

$$Va = Vin * Na / Np = 214V * 15 / 100 * (-1) = -32.1V$$

$$Rzc = Va / I_{ZT} = -32.1V / -1mA = 32.1k\Omega$$

Therefore, set to Rzt=32KΩ

(4-5) Determination of OFF Width(Turn on)

OFF width is controlled at the ZT pin. When OUT is Low, the power stored in the coil is supplied to the secondary-side output capacitor. When this power supply ends, there is no more current flowing to the secondary side, so the drain voltage of switching MOSFET drops. Consequently, the voltage on the auxiliary winding side also drops. A voltage that was resistance-divided by Rzt1 and Rzt2 is applied to ZT pin. When this voltage level drops to V_{ZT1} (100 mV typ) or below, MOSFET is turned ON by the ZT comparator. Since zero current status is detected at the ZT pin, time constants are generated using Czt, Rzt1, and Rzt2.

However, since Rzt1 and Rzt2 setting is required in AC voltage compensation function and ZTOVP function, bottom time adjustment is set in Czt capacitor.

OFF time is calculated below equation:

$$Toff1 = Ls / (Vout + VF) * Is \quad (Toff1 : \text{transformer discharge time, } Ls : \text{secondary inductance, } Vout : \text{Secondary output, } VF : \text{secondary diode forward voltage, } Is : \text{secondary peak current})$$

For that, switching frequency is calculated below:

$$\text{switching frequency} = 1 / \{ \text{transformer charge and discharge time}(Ton + Toff1) + (\text{bottom}-1) \times \text{resonant time} + (1/2 \times \text{resonant time}) \}$$

$$\text{resonant time} = 1 / (2 \times \pi \times \sqrt{Lp \times Cds})$$

* Lp: primary inductance, MOSFET D-S capacitor: Cds

Because frequency reduction range in light load restricts shown Fig-16, bottom detection operates by the frequency which is lower than max frequency function in Fig-16.

Additionally, a ZT trigger mask function (described in section 4-6) and a ZT timeout function (described in section 4-7) are built in IC.

(4-6) ZT Trigger Mask Function (Fig-22)

When switching is set from ON to OFF, superposition of noise may occur at the ZT pin. Then, the ZT comparator and ZTOVP comparator are masked for the T_{ZTMASK} time to prevent ZT comparator operation errors.

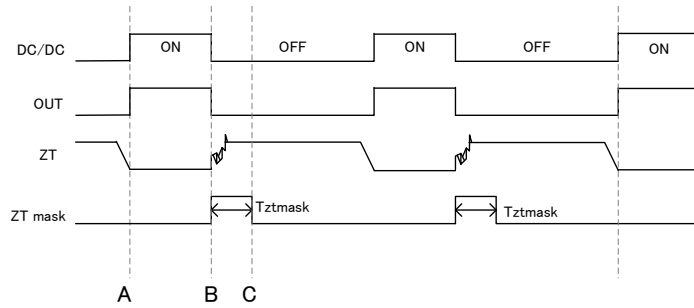

Fig-21 ZT Trigger Mask Function

- A: DC/DC OFF=>ON
- B: DC/DC ON=>OFF then the surge noise occurs to ZT pin.
- C: Since a noise occurs to ZT pin at B, IC masks ZT comparator and ZTOVP comparator detection for T_{ZTMASK} time.

(4-7-1) ZT Timeout Function1 (Fig-23)

When ZT pin voltage is not higher than V_{ZT2} (typ=200mV) for T_{ZTOUT1} (typ=15us) such as start or low output voltage, ZT pin short, IC turns on MOSFET by force.

(4-7-2) ZT Timeout Function2 (Fig-23)

After ZT comparator detects bottom, when IC does not detect next bottom within T_{ZTOUT2} (typ =5us), IC turns on MOSFET by force. After ZT comparator detects bottom at once, the function operates. For that, it does not operate at start or at low output voltage. When IC is not able to detect bottom by decreasing auxiliary winding voltage, the function operates.

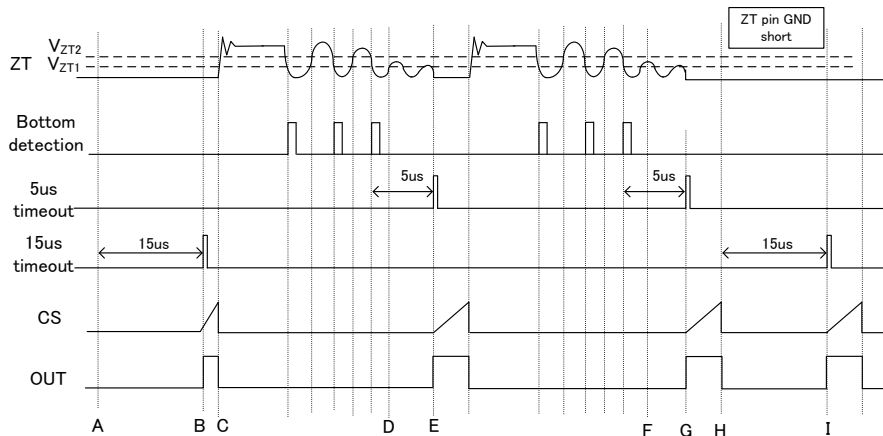

Fig-22 ZT Timeout Function

- A: When starting, IC starts to operate by ZT timeout function1 for $ZT=0V$.
- B: MOSFET turns ON
- C: MOSFET turns OFF
- D: ZT voltage is lower than V_{ZT2} (typ=200mV) by ZT dump decreasing.
- E: MOSFET turns ON by ZT timeout function2 after T_{ZT2} (typ=5us) from D point.
- F: ZT voltage is lower than V_{ZT2} (typ=200mV) by ZT dump decreasing.
- G: MOSFET turns ON by ZT timeout function2 after T_{ZT2} (typ=5us) from F point.
- H: ZT pin is short to GND.
- I: MOSFET turns ON by ZT timeout function1 after T_{ZTOUT1} (typ=15us)

(5) Soft Start Sequence

Normally, when AC voltage is applied, a large current flows. Then secondary output voltage and current is occurred overshoot. For preventing it, IC built in soft-start function.
 When VCC pin(6pin) voltage is lower than V_{UVLO2} (typ =8.2V), IC is reset. After that, when AC voltage is applied, IC operates soft-start.

The soft start function is below: (Please refer to (4-1) turn off item about CS limiter.)

- start ~ 0.5ms => Set CS limiter to 12.5% of normal operation.
- 0.5ms~1ms => Set CS limiter to 25% of normal operation.
- 1ms~2ms => Set CS limiter to 50% of normal operation.
- 2ms~4ms => Set CS limiter to 75% of normal operation.
- 4ms~ => normal operation

(6) ZT pin (1pin) OVP (Over Voltage Protection)

IC build-in OVP function to ZT (1pin). It is latch type in BM1Q002, and none in BM1Q001.
 ZTOVP operates by DC voltage detection and pulse detection for ZT pin.

[BM1Q002]

When ZT pin(1pin) voltage is over V_{ZTL} (typ=5.0V), IC starts to detect ZTOVP function.
 For DC voltage detection, when the state which ZT voltage is larger than V_{ZTL} (typ=5.0V) continues for 100us, IC carries out latch stop.

To prevent ZT (1pin) OVP from miss-detecting by surge noise, IC builds in 3count and T_{LATCH} (typ=100us) timer.

ZT (1pin) OVP function operates in all states (normal state and over load state and burst state).

For pulse detection, ZT (1pin) OVP operation starts detection after T_{ZTMASK} delay time from OUT:H→L.

When the pulse of ZT (1pin) voltage larger than V_{ZTL} (typ=5.0V) is applied 3 count and for T_{LATCH} (typ=100us)time, IC carries out latch stop.

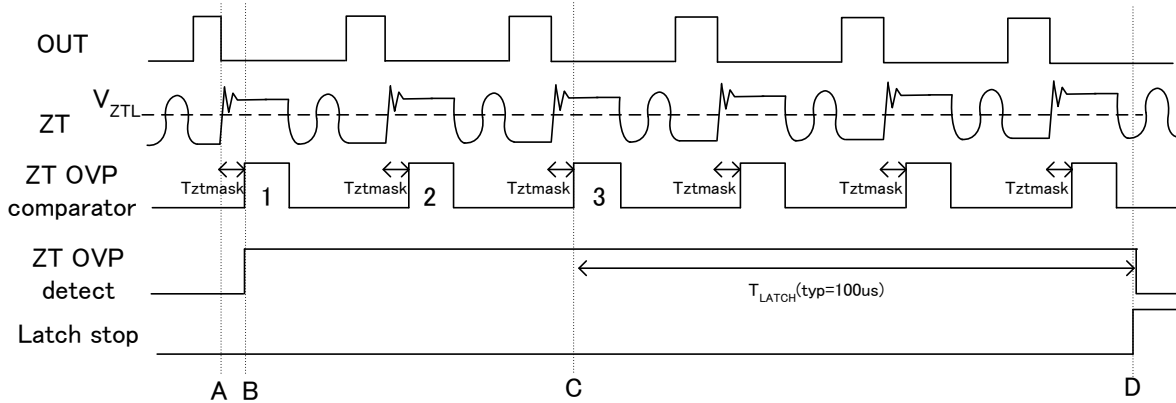

Fig-23 ZTOVP and Latch Blanking Function

- A: When OUT (5pin) voltage is changed from H to L, ZT (1pin) voltage is up. Then, surge pulse occurs to ZT (1pin). For that, because IC builds in T_{ztmask} time (typ=0.6us), IC does not detect ZTOVP for T_{ztmask} time.
- B: After T_{ztmask} time (typ=0.6us), ZT OVP detects over voltage.
- C: When ZTOVP comparator counts 3 pulse, T_{LATCH} timer (typ=100us) operates.
- D: When it takes for 100us from C, IC detects ZT OVP and IC carries out latch stop.

It shows ZT OVP voltage setting method below. (auxiliary winding voltage : V_a , ZT upper resistor : R_{zt1} , ZT lower resistor : R_{zt2})
 Secondary voltage : V_o , transformer winding ratio(secondary / auxiliary) : N_s/N_a , ZT input current : I_{zt}

The voltage which detects over voltage protection in secondary side : $VOVP$
 $VOVP = (N_a/N_s) * V_a = (N_a/N_s) * \{V_{ZT} * (R_{zt1} + R_{zt2}) / (R_{zt2} + R_{zt1} * I_{zt})\}$

When ZT voltage = 5.35V, ZT input current is calculated to $I_{zt(max)}=28\mu A$, OVP maximum voltage is set below:

$$VOVP(max) = (N_a/N_s) / \{5.35 * (R_{zt1} + R_{zt2}) / (R_{zt2} + R_{zt1} * 28\mu A)\}$$

R_{zt1} setting is decided by AC voltage compensation function of (4-4).

R_{zt2} setting is calculated below

$$R_{zt2} = V_{ztovp} * R_{zt1} / \{V_{ovp} * (N_a/N_s) - I_{zt} * R_{zt1} - V_{ztovp}\}$$

(7) CS (3pin) Open Protection

When CS (3pin) is OPEN, to prevent OUT pin from changing to H by noise, IC builds in CS(3pin) open protection. When CS (3pin) is open, OUT (5pin) switching is stopped by the function. (This is auto-recovery)

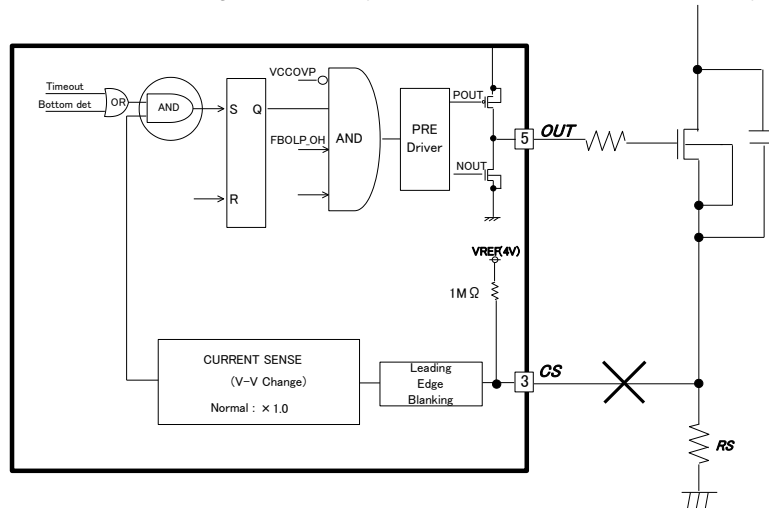

Fig-24 CS Open Protection

(8) OUTPUT Over Load Protection (FB OLP comparator)

When secondary output is over load, IC detects it by FB (2pin), IC stops switching. In OLP state, because secondary photo-coupler is not flown current, FB (2pin) voltage is up. When the condition continues for T_{FOLP} (typ =64ms), IC judges over load state, OUT (5pin) is L fixed. After FB (2pin) voltage is over V_{FOLP1A} (typ =2.8V), when FB (2pin) voltage is lower than V_{FOLP1B} (typ =2.6V) within T_{FOLP} (typ =64ms), over load protection timer is reset. In starting, because FB (2pin) is pull-up by a resistor to internal voltage, FB (2pin) voltage starts to operate in the state which is more than V_{FOLP1A} (typ =2.8V). For that, please set stable time of secondary output voltage within T_{FOLP} (typ =64ms). After detecting over load, IC is stopped for T_{OLPST} (typ =512ms), IC is auto-recovery operation. In stopping switching, though VCC (6pin) voltage falls, but IC operates re-charge function by starter circuit, VCC (6pin) voltage keeps VCC pin voltage > V_{UVLO2} .

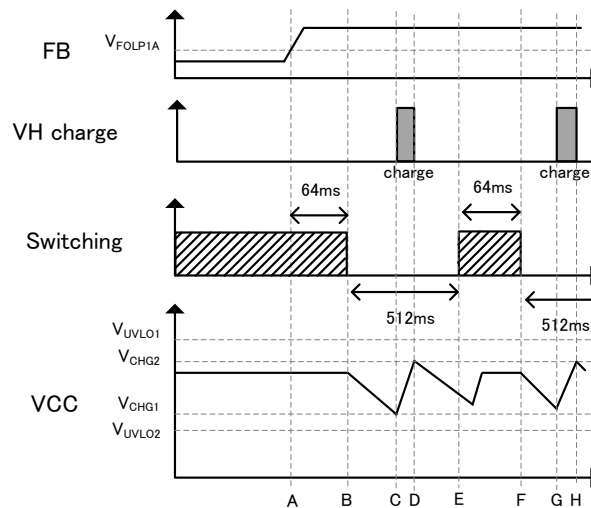

Fig-25 Over Load Protection : Auto-recovery

- A: When FB voltage is over V_{FOLP1A} (typ=2.8V), FBOLP comparator detects over load.
- B: When the state A continues for T_{FOLP} (typ=64ms), IC stops switching by over load protection.
- C: During stopping switching by over load protection, VCC (6pin) voltage drops. When VCC (6pin) voltage is lower than V_{CHG1} , VCC re-charge function operate, VCC (6pin) voltage is up.
- D: When VCC (6pin) voltage is higher than V_{CHG2} by re-charge function, VCC recharge function is stopped.
- E: From B, it takes for T_{OLPST} (typ =512ms), IC starts switching with soft-start.
- F: When over load state continues, FB (2pin) voltage is over V_{FOLP1A} . When it takes for T_{FOLP} (typ=64ms) from E, IC stops switching.
- G: During stopping switching by over load protection, VCC (6pin) voltage drops. When VCC (6pin) voltage is lower than V_{CHG1} , VCC re-charge function operate, VCC (6pin) voltage is up.
- H: When VCC (6pin) voltage is higher than V_{CHG2} by re-charge function, VCC recharge function is stopped.

(9) OUT(5pin) Voltage Clamp Function

By the purpose which protects external MOSFET, H level of OUT (5pin) is clamped to $V_{OUTH}(typ=12.5V)$ It prevents gate destruction of MOSFET by rising VCC (6pin) voltage. (It refers to Fig-23)
 OUT (5pin) is pull-down $R_{PDOUT}(typ=100k\Omega)$.

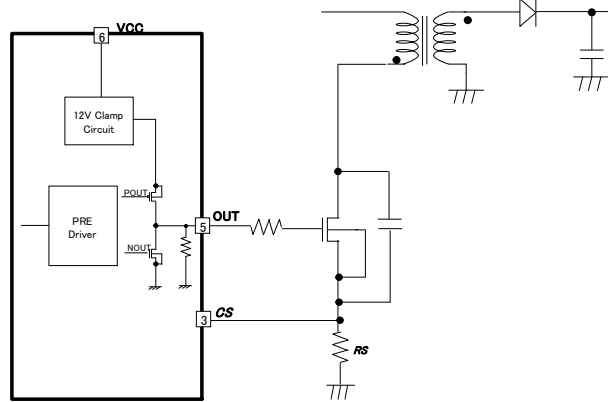

Fig-26 OUT(5pin) Construction

●Operation Mode of Protection Circuit

Operation mode of protection functions are shown in table3.

Table3 Operation Mode of Protection Circuit

項目	Protection Mode	
	BM1Q001FJ	BM1Q002FJ
VCC Under Voltage Locked Out	Self-restart	Self-restart
VCC Over Voltage Protection	Self-restart (100us with timer)	Latch (100us with timer)
FB Over Load Protection	Self-restart(64ms delay, 512ms stop)	Self-restart(64ms delay, 512ms stop)
CS Open Protection	Self-restart	Self-restart
ZT Over Voltage Protection	None	Latch (100us with timer)
VCC Charge Protection	Self-restart	Self-restart

● Power Dissipation

The thermal design should set operation for the following conditions.
 (Since the temperature shown below is the guaranteed temperature, be sure to take a margin into account.)

1. The ambient temperature T_a must be 105°C or less.
2. The IC's loss must be within the allowable dissipation P_d .

The thermal abatement characteristics are as follows.
 (PCB: 70 mm × 70 mm × 1.6 mm, mounted on glass epoxy substrate)

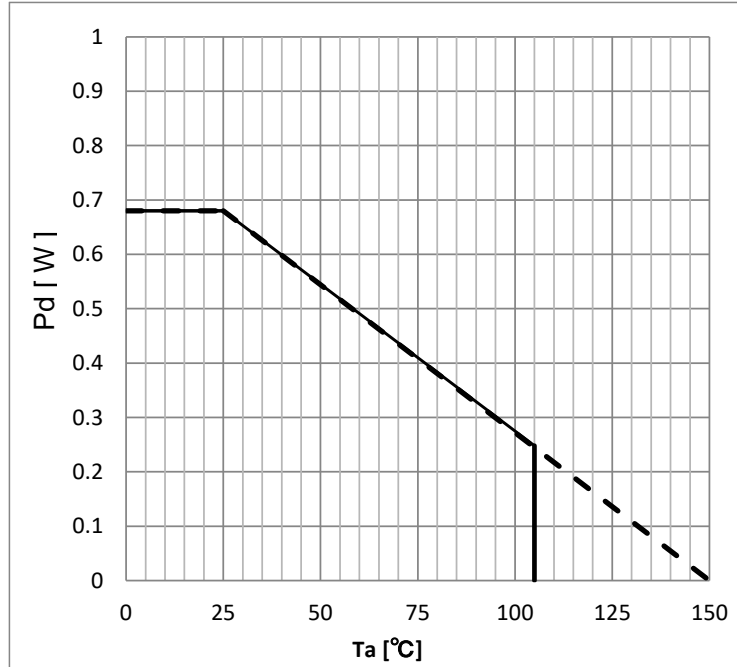

Fig-27 SOP-J8 Thermal Abatement Characteristics

Operational Notes

1. Reverse Connection of Power Supply

Connecting the power supply in reverse polarity can damage the IC. Take precautions against reverse polarity when connecting the power supply, such as mounting an external diode between the power supply and the IC's power supply terminals.

2. Power Supply Lines

Design the PCB layout pattern to provide low impedance supply lines. Separate the ground and supply lines of the digital and analog blocks to prevent noise in the ground and supply lines of the digital block from affecting the analog block. Furthermore, connect a capacitor to ground at all power supply pins. Consider the effect of temperature and aging on the capacitance value when using electrolytic capacitors.

3. Ground Voltage

Except for pins the output and the input of which were designed to go below ground, ensure that no pins are at a voltage below that of the ground pin at any time, even during transient condition.

4. Ground Wiring Pattern

When using both small-signal and large-current ground traces, the two ground traces should be routed separately but connected to a single ground at the reference point of the application board to avoid fluctuations in the small-signal ground caused by large currents. Also ensure that the ground traces of external components do not cause variations on the ground voltage. The ground lines must be as short and thick as possible to reduce line impedance.

5. Thermal Consideration

Should by any chance the power dissipation rating be exceeded, the rise in temperature of the chip may result in deterioration of the properties of the chip. The absolute maximum rating of the Pd stated in this specification is when the IC is mounted on a 70mm x 70mm x 1.6mm glass epoxy board. In case of exceeding this absolute maximum rating, increase the board size and copper area to prevent exceeding the Pd rating.

6. Recommended Operating Conditions

These conditions represent a range within which the expected characteristics of the IC can be approximately obtained. The electrical characteristics are guaranteed under the conditions of each parameter.

7. Rush Current

When power is first supplied to the IC, it is possible that the internal logic may be unstable and inrush current may flow instantaneously due to the internal powering sequence and delays, especially if the IC has more than one power supply. Therefore, give special consideration to power coupling capacitance, power wiring, width of ground wiring, and routing of connections.

8. Operation Under Strong Electromagnetic Field

Operating the IC in the presence of a strong electromagnetic field may cause the IC to malfunction.

9. Testing on Application Boards

When testing the IC on an application board, connecting a capacitor directly to a low-impedance output pin may subject the IC to stress. Always discharge capacitors completely after each process or step. The IC's power supply should always be turned off completely before connecting or removing it from the test setup during the inspection process. To prevent damage from static discharge, ground the IC during assembly and use similar precautions during transport and storage.

10. Inter-pin Short and Mounting Errors

Ensure that the direction and position are correct when mounting the IC on the PCB. Incorrect mounting may result in damaging the IC. Avoid nearby pins being shorted to each other especially to ground, power supply and output pin. Inter-pin shorts could be due to many reasons such as metal particles, water droplets (in very humid environment) and unintentional solder bridge deposited in between pins during assembly to name a few.

Operational Notes – continued

11. Unused Input Terminals

Input terminals of an IC are often connected to the gate of a MOS transistor. The gate has extremely high impedance and extremely low capacitance. If left unconnected, the electric field from the outside can easily charge it. The small charge acquired in this way is enough to produce a significant effect on the conduction through the transistor and cause unexpected operation of the IC. So unless otherwise specified, unused input terminals should be connected to the power supply or ground line.

12. Regarding the Input Pin of the IC

This monolithic IC contains P+ isolation and P substrate layers between adjacent elements in order to keep them isolated. P-N junctions are formed at the intersection of the P layers with the N layers of other elements, creating a parasitic diode or transistor. For example (refer to figure below):

When GND > Pin A and GND > Pin B, the P-N junction operates as a parasitic diode.
 When GND > Pin B, the P-N junction operates as a parasitic transistor.

Parasitic diodes inevitably occur in the structure of the IC. The operation of parasitic diodes can result in mutual interference among circuits, operational faults, or physical damage. Therefore, conditions that cause these diodes to operate, such as applying a voltage lower than the GND voltage to an input pin (and thus to the P substrate) should be avoided.

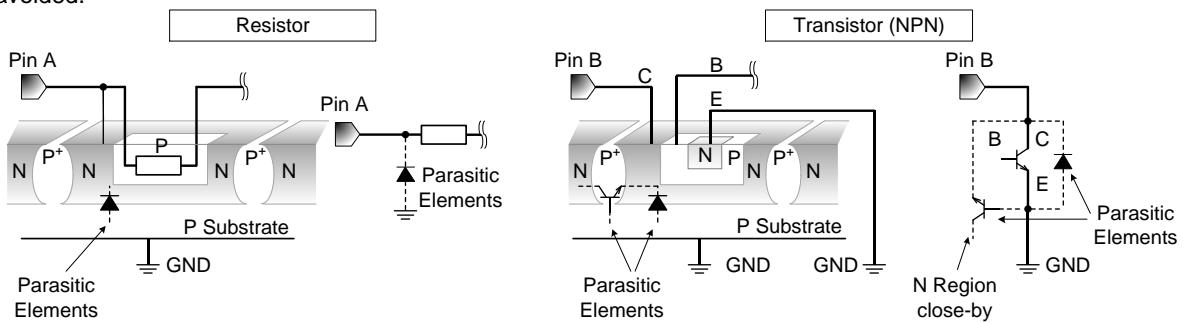

Figure 40. Example of monolithic IC structure

13. Ceramic Capacitor

When using a ceramic capacitor, determine the dielectric constant considering the change of capacitance with temperature and the decrease in nominal capacitance due to DC bias and others.

14. Area of Safe Operation (ASO)

Operate the IC such that the output voltage, output current, and power dissipation are all within the Area of Safe Operation (ASO).

15. Thermal Shutdown Circuit(TSD)

This IC has a built-in thermal shutdown circuit that prevents heat damage to the IC. Normal operation should always be within the IC's power dissipation rating. If however the rating is exceeded for a continued period, the junction temperature (T_j) will rise which will activate the TSD circuit that will turn OFF all output pins. When the T_j falls below the TSD threshold, the circuits are automatically restored to normal operation.

Note that the TSD circuit operates in a situation that exceeds the absolute maximum ratings and therefore, under no circumstances, should the TSD circuit be used in a set design or for any purpose other than protecting the IC from heat damage.

Status of this document

The Japanese version of this document is formal specification. A customer may use this translation version only for a reference to help reading the formal version.

If there are any differences in translation version of this document formal version takes priority

●Ordering Information

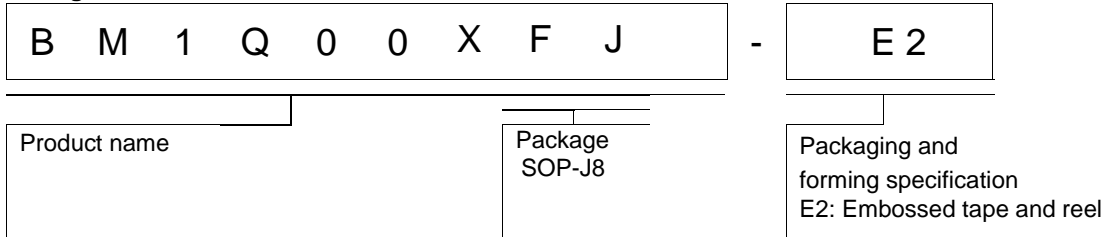

●Marking Diagram

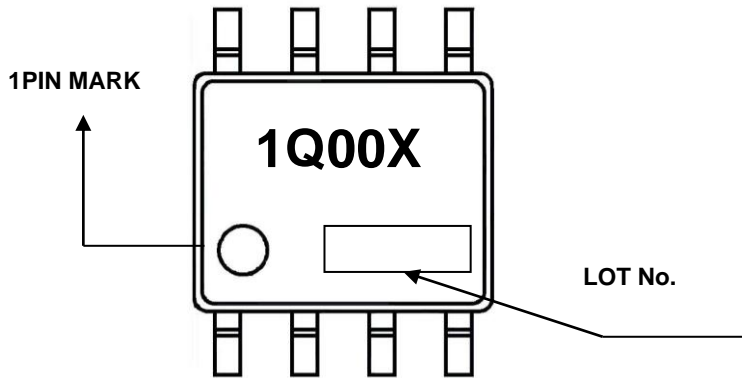

●Line Up

Product (BM1Q00XFJ)
BM1Q001FJ
BM1Q002FJ

●Physical Dimension Tape and Reel Information

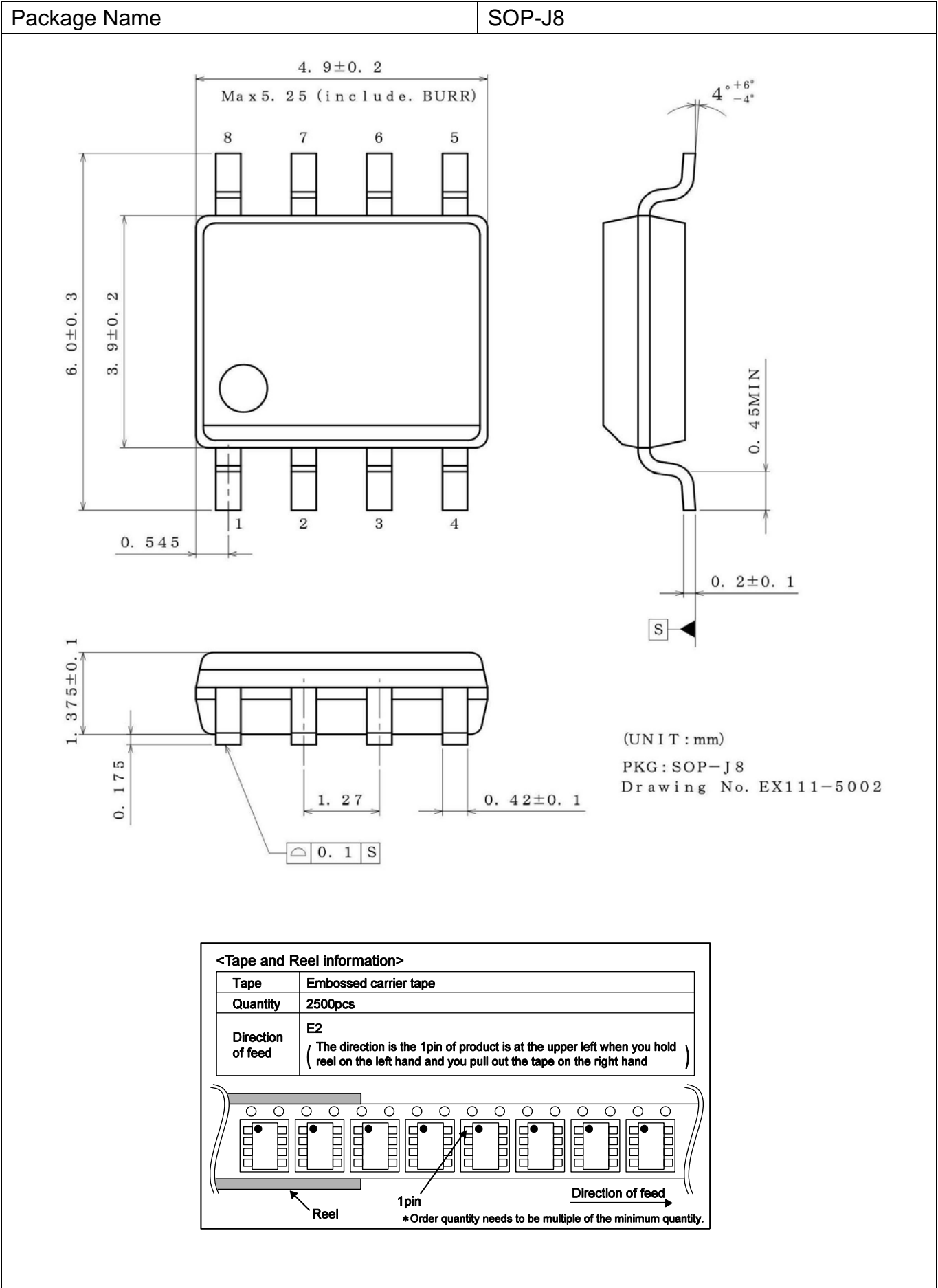

●Revision History

Date	Revision	Changes
2013.04.05	001	New Release
2014.03.07	002	Datasheet Format modified
2014.03.07	002	P-17 calculation change : Resonant time = $1 / (2 \times \pi \times (L_p \times C_d))$ Add " $\sqrt{\quad}$ "
2014.03.07	002	P-17 Delete Figure-27
2014.03.07	002	Change Operational Notes
2015.06.17	003	P-1,P-8,P-13 Modify transformer polarity in figure
2017.01.25	004	P1 size of the package P1 Operate temperature range P2 Operate temperature range P4 External Dimensions P7 a value of Figure8 P13 a value of Figure14 P16 a value of Figure18
2020.12.28	005	Updated packages and part numbers P27-2,P27-3

●Ordering Information

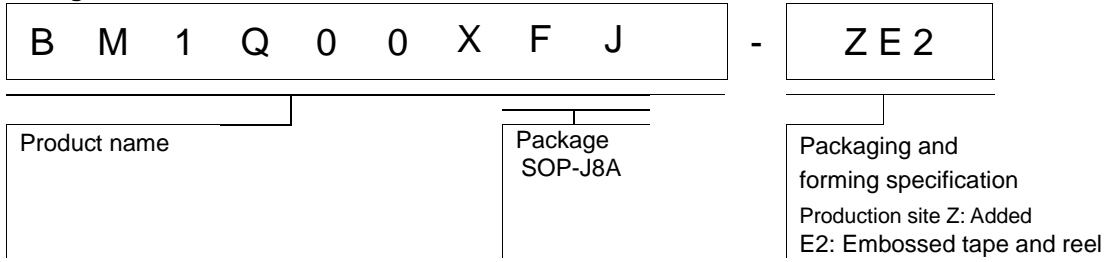

●Marking Diagram

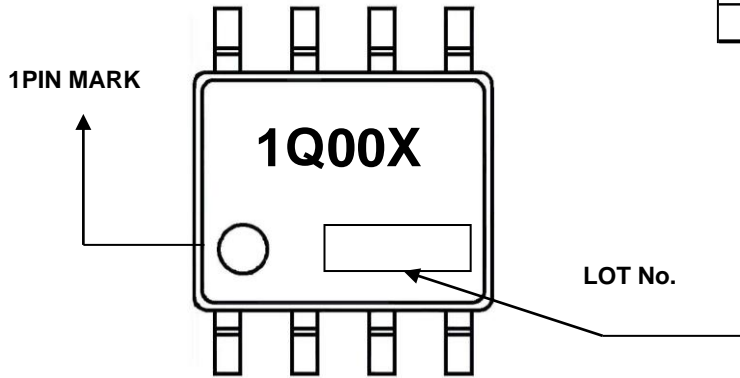

●Line Up

Product (BM1Q00XFJ)
BM1Q001FJ
BM1Q002FJ

Physical Dimension and Packing Information

Package Name	SOP-J8A
--------------	---------

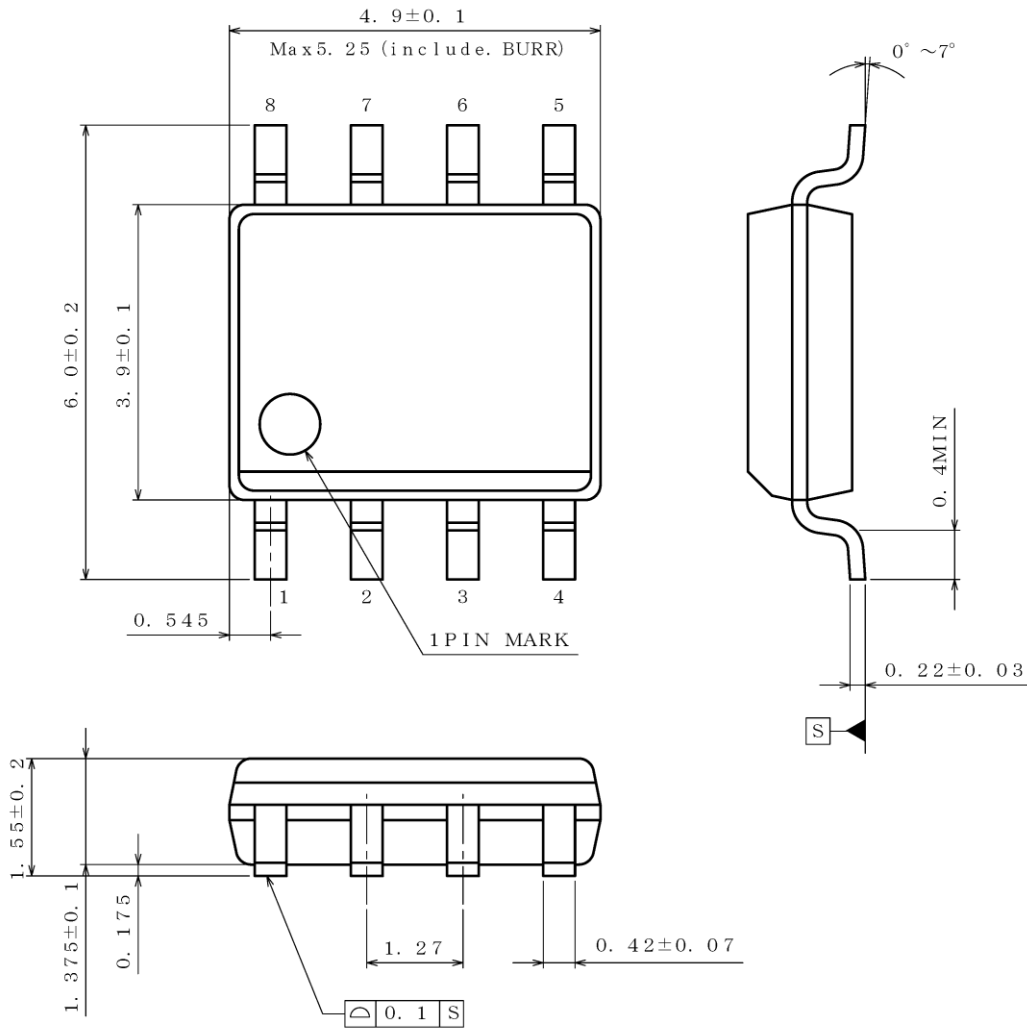

(UNIT : mm)
 PKG : SOP-J8A
 Drawing No. EX001-0055-2

< Tape and Reel Information >

Tape	Embossed carrier tape
Quantity	2500pcs
Direction of feed	E2 The direction is the pin 1 of product is at the upper left when you hold reel on the left hand and you pull out the tape on the right hand

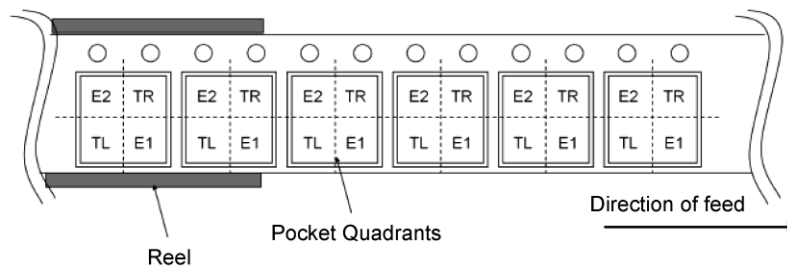

Notice

Precaution on using ROHM Products

- Our Products are designed and manufactured for application in ordinary electronic equipment (such as AV equipment, OA equipment, telecommunication equipment, home electronic appliances, amusement equipment, etc.). If you intend to use our Products in devices requiring extremely high reliability (such as medical equipment ^(Note 1), transport equipment, traffic equipment, aircraft/spacecraft, nuclear power controllers, fuel controllers, car equipment including car accessories, safety devices, etc.) and whose malfunction or failure may cause loss of human life, bodily injury or serious damage to property ("Specific Applications"), please consult with the ROHM sales representative in advance. Unless otherwise agreed in writing by ROHM in advance, ROHM shall not be in any way responsible or liable for any damages, expenses or losses incurred by you or third parties arising from the use of any ROHM's Products for Specific Applications.

(Note1) Medical Equipment Classification of the Specific Applications

JAPAN	USA	EU	CHINA
CLASS III	CLASS III	CLASS II b	CLASS III
CLASS IV		CLASS III	

- ROHM designs and manufactures its Products subject to strict quality control system. However, semiconductor products can fail or malfunction at a certain rate. Please be sure to implement, at your own responsibilities, adequate safety measures including but not limited to fail-safe design against the physical injury, damage to any property, which a failure or malfunction of our Products may cause. The following are examples of safety measures:
 - Installation of protection circuits or other protective devices to improve system safety
 - Installation of redundant circuits to reduce the impact of single or multiple circuit failure
- Our Products are designed and manufactured for use under standard conditions and not under any special or extraordinary environments or conditions, as exemplified below. Accordingly, ROHM shall not be in any way responsible or liable for any damages, expenses or losses arising from the use of any ROHM's Products under any special or extraordinary environments or conditions. If you intend to use our Products under any special or extraordinary environments or conditions (as exemplified below), your independent verification and confirmation of product performance, reliability, etc. prior to use, must be necessary:
 - Use of our Products in any types of liquid, including water, oils, chemicals, and organic solvents
 - Use of our Products outdoors or in places where the Products are exposed to direct sunlight or dust
 - Use of our Products in places where the Products are exposed to sea wind or corrosive gases, including Cl₂, H₂S, NH₃, SO₂, and NO₂
 - Use of our Products in places where the Products are exposed to static electricity or electromagnetic waves
 - Use of our Products in proximity to heat-producing components, plastic cords, or other flammable items
 - Sealing or coating our Products with resin or other coating materials
 - Use of our Products without cleaning residue of flux (Exclude cases where no-clean type fluxes is used. However, recommend sufficiently about the residue.) ; or Washing our Products by using water or water-soluble cleaning agents for cleaning residue after soldering
 - Use of the Products in places subject to dew condensation
- The Products are not subject to radiation-proof design.
- Please verify and confirm characteristics of the final or mounted products in using the Products.
- In particular, if a transient load (a large amount of load applied in a short period of time, such as pulse, is applied, confirmation of performance characteristics after on-board mounting is strongly recommended. Avoid applying power exceeding normal rated power; exceeding the power rating under steady-state loading condition may negatively affect product performance and reliability.
- De-rate Power Dissipation depending on ambient temperature. When used in sealed area, confirm that it is the use in the range that does not exceed the maximum junction temperature.
- Confirm that operation temperature is within the specified range described in the product specification.
- ROHM shall not be in any way responsible or liable for failure induced under deviant condition from what is defined in this document.

Precaution for Mounting / Circuit board design

- When a highly active halogenous (chlorine, bromine, etc.) flux is used, the residue of flux may negatively affect product performance and reliability.
- In principle, the reflow soldering method must be used on a surface-mount products, the flow soldering method must be used on a through hole mount products. If the flow soldering method is preferred on a surface-mount products, please consult with the ROHM representative in advance.

For details, please refer to ROHM Mounting specification

Precautions Regarding Application Examples and External Circuits

1. If change is made to the constant of an external circuit, please allow a sufficient margin considering variations of the characteristics of the Products and external components, including transient characteristics, as well as static characteristics.
2. You agree that application notes, reference designs, and associated data and information contained in this document are presented only as guidance for Products use. Therefore, in case you use such information, you are solely responsible for it and you must exercise your own independent verification and judgment in the use of such information contained in this document. ROHM shall not be in any way responsible or liable for any damages, expenses or losses incurred by you or third parties arising from the use of such information.

Precaution for Electrostatic

This Product is electrostatic sensitive product, which may be damaged due to electrostatic discharge. Please take proper caution in your manufacturing process and storage so that voltage exceeding the Products maximum rating will not be applied to Products. Please take special care under dry condition (e.g. Grounding of human body / equipment / solder iron, isolation from charged objects, setting of Ionizer, friction prevention and temperature / humidity control).

Precaution for Storage / Transportation

1. Product performance and soldered connections may deteriorate if the Products are stored in the places where:
 - [a] the Products are exposed to sea winds or corrosive gases, including Cl₂, H₂S, NH₃, SO₂, and NO₂
 - [b] the temperature or humidity exceeds those recommended by ROHM
 - [c] the Products are exposed to direct sunshine or condensation
 - [d] the Products are exposed to high Electrostatic
2. Even under ROHM recommended storage condition, solderability of products out of recommended storage time period may be degraded. It is strongly recommended to confirm solderability before using Products of which storage time is exceeding the recommended storage time period.
3. Store / transport cartons in the correct direction, which is indicated on a carton with a symbol. Otherwise bent leads may occur due to excessive stress applied when dropping of a carton.
4. Use Products within the specified time after opening a humidity barrier bag. Baking is required before using Products of which storage time is exceeding the recommended storage time period.

Precaution for Product Label

A two-dimensional barcode printed on ROHM Products label is for ROHM's internal use only.

Precaution for Disposition

When disposing Products please dispose them properly using an authorized industry waste company.

Precaution for Foreign Exchange and Foreign Trade act

Since concerned goods might be fallen under listed items of export control prescribed by Foreign exchange and Foreign trade act, please consult with ROHM in case of export.

Precaution Regarding Intellectual Property Rights

1. All information and data including but not limited to application example contained in this document is for reference only. ROHM does not warrant that foregoing information or data will not infringe any intellectual property rights or any other rights of any third party regarding such information or data.
2. ROHM shall not have any obligations where the claims, actions or demands arising from the combination of the Products with other articles such as components, circuits, systems or external equipment (including software).
3. No license, expressly or implied, is granted hereby under any intellectual property rights or other rights of ROHM or any third parties with respect to the Products or the information contained in this document. Provided, however, that ROHM will not assert its intellectual property rights or other rights against you or your customers to the extent necessary to manufacture or sell products containing the Products, subject to the terms and conditions herein.

Other Precaution

1. This document may not be reprinted or reproduced, in whole or in part, without prior written consent of ROHM.
2. The Products may not be disassembled, converted, modified, reproduced or otherwise changed without prior written consent of ROHM.
3. In no event shall you use in any way whatsoever the Products and the related technical information contained in the Products or this document for any military purposes, including but not limited to, the development of mass-destruction weapons.
4. The proper names of companies or products described in this document are trademarks or registered trademarks of ROHM, its affiliated companies or third parties.