



650 V GaN HEMT Power Stage

BM3G015MUV-EVK-003

User's Guide

<High Voltage Safety Precautions>

◇ Read all safety precautions before use

Please note that this document covers only the **BM3G015MUV** evaluation board (BM3G015MUV-EVK-003) and its functions. For additional information, please refer to the datasheet.

To ensure safe operation, please carefully read all precautions before handling the evaluation board



Depending on the configuration of the board and voltages used,

Potentially lethal voltages may be generated.

Therefore, please make sure to read and observe all safety precautions described in the red box below.

Before Use

- [1] Verify that the parts/components are not damaged or missing (i.e. due to the drops).
- [2] Check that there are no conductive foreign objects on the board.
- [3] Be careful when performing soldering on the module and/or evaluation board to ensure that solder splash does not occur.
- [4] Check that there is no condensation or water droplets on the circuit board.

During Use

- [5] Be careful to not allow conductive objects to come into contact with the board.
- [6] **Brief accidental contact or even bringing your hand close to the board may result in discharge and lead to severe injury or death.**

Therefore, DO NOT touch the board with your bare hands or bring them too close to the board.

In addition, as mentioned above please exercise extreme caution when using conductive tools such as tweezers and screwdrivers.

- [7] If used under conditions beyond its rated voltage, it may cause defects such as short-circuit or, depending on the circumstances, explosion or other permanent damages.
- [8] Be sure to wear insulated gloves when handling is required during operation.

After Use

- [9] The ROHM Evaluation Board contains the circuits which store the high voltage. Since it stores the charges even after the connected power circuits are cut, please discharge the electricity after using it, and please deal with it after confirming such electric discharge.
- [10] Protect against electric shocks by wearing insulated gloves when handling.

This evaluation board is intended for use only in research and development facilities and should be handled **only by qualified personnel familiar with all safety and operating procedures.**

We recommend carrying out operation in a safe environment that includes the use of high voltage signage at all entrances, safety interlocks, and protective glasses.

650 V GaN HEMT Power Stage BM3G015MUV Evaluation Board

BM3G015MUV-EVK-003

General Description

The BM3G015MUV-EVK-003 evaluation board consists of the BM3G015MUV (GaN FET (650 V 150 mΩ), integrated driver and protection circuit) and A board on which peripheral components are mounted.

This IC is designed to adapt major exist controllers, so that it also can be used to replace the traditional discrete power switches, such as super junction MOSFET.



Figure 1. BM3G015MUV-EVK-003

Performance Specification

Not guarantee the characteristics is representative value.

Unless otherwise specified $V_{DD} = 15\text{ V}$ $V_{BUS} = 200\text{ V}$, $T_j = 25\text{ }^\circ\text{C}$

Parameter	Symbol	Min	Typ	Max	Units	Conditions
Power Supply Voltage Range	V_{DD}	6.25	15	35	V	
Drain Voltage Range	V_{DRAIN}	-	-	650	V	
VDD Quiescent Current	I_{ON2}	-	0.18	0.24	mA	$V_{IN} = 0\text{ V}$
Positive-going Input Threshold	V_{IN_POS}	1.60	1.80	2.00	V	
Negative-going Input Threshold	V_{IN_NEG}	1.05	1.30	1.55	V	
Turn-on Slew Rate	SR_{ON1}		28		V/ns	
Operating Temperature		-10	+25	+105	$^\circ\text{C}$	

Measurement Circuits

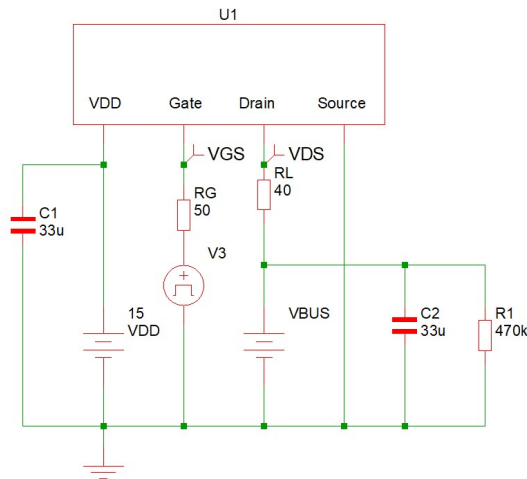

Operation Procedure

1. Operation Equipment

- (1) DC power supply (400 VDC, 100 W or more)
- (2) DC power supply (30 VDC, 10 W or more)
- (3) Oscilloscope
- (4) Oscillator

2. Connect method

- (1) Preset the DC supply 1 to 200 V and turn off the DC supply output.
- (2) Preset the DC supply 2 to 15 V and turn off the DC supply output.
- (3) Turn off the oscillator output.
- (4) As shown in the connection diagram, connect the evaluation board to each measuring instrument and DC supply.
- (5) Turn on the output of DC supply 1 and DC supply 2, and turn on the output of the oscillator.
- (6) Check the voltage on the D and G pins

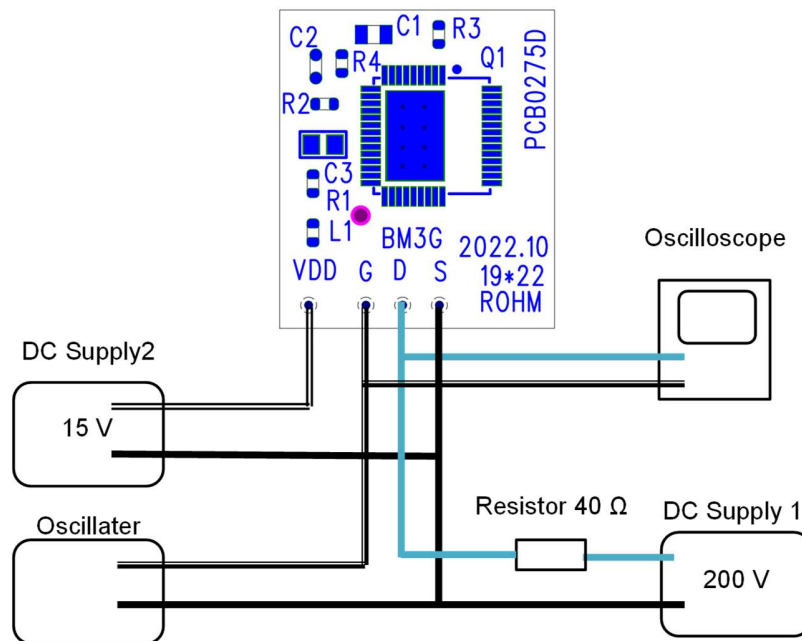

Figure 2. Diagram of How to Connect

Schematics

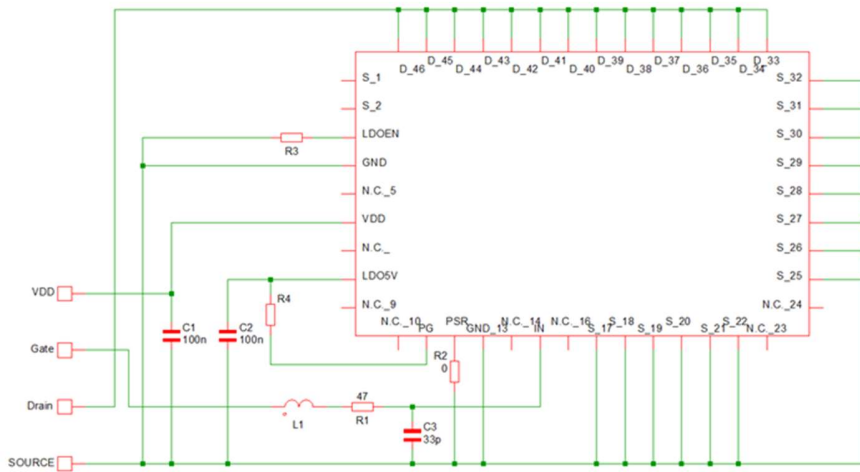

Figure 3. BM3G015MUV-EVK-003 Schematics

Parts List

Item	Specification	Parts Name	Manufacturer
C1	0.1 μ F, 50 V	GRM188R72A104KA35D	MURATA
C2	0.1 μ F, 50 V	GRM188R72A104KA35D	MURATA
C3	30 pF, 50 V	GRM1882C1H330JA01#	MURATA
IC1	Rdson 150 m Ω , 650 V	BM3G015MUV	ROHM
L1	600 Ω at 100MHz	BLM18AG601SN1D	MURATA
R1	47 Ω	MCR03EZPJ470	ROHM
R2	0 Ω	MCR03EZPJ000	ROHM
R3		Non-Mounted	
R4		Non-Mounted	
PCB		PCB0275D	SIGNAS

Materials may be changed without notifying.

Layout

Size: 19 mm x 22 mm

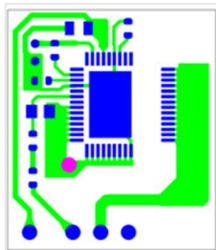

Figure 4. TOP Layout (Top view)

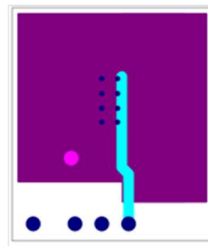

Figure 5. Bottom Layout (Top View)

BM3G015MUV General Description

Features

- Nano Cap™ Integrated Output Selectable 5 V LDO
- Long Time Support Product for Industrial Applications
- Wide Operating Range for VDD Pin Voltage
- Wide Operating Range for IN Pin Voltage
- Low VDD Quiescent and Operating Current
- Low Propagation Delay
- High dv/dt Immunity
- Adjustable Gate Drive Strength
- Power Good Signal Output
- VDD UVLO Protection
- Thermal Shutdown Protection

Key Specifications

- Power Supply Voltage Range
 - VDD pin: 6.25 V to 30 V
 - D pin: 650 V (Max)
 - IN pin: -0.6 V to +30 V
- VDD Operating Current @ 130 kHz: 650 μA (Typ)
- VDD Quiescent Current: 180 μA (Typ)
- Allowable Input Switching Frequency: 2 MHz (Max)
- Turn-on Delay Time: 12 ns (Typ)
- Turn-off Delay Time: 15 ns (Typ)
- Operating Temperature Range: -40 °C to +105 °C
- GaN HEMT D-S ON State Resistance: 150 mΩ (Typ)

Pin Configuration

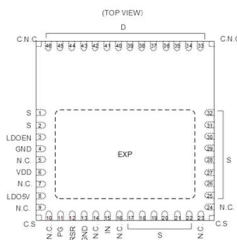

Package

W (Typ) x D (Typ) x H (Max)

VQFN046V8080

8.0 mm x 8.0 mm x 1.0 mm

pitch 0.5 mm

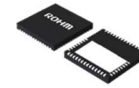

Figure 6. Pin Configuration

Pin Descriptions

Pin No.	Pin Name	I/O	Function
1,2,17-22,24-32	S	O	GaN HEMT SOURCE pin
3	LDOEN	I	LDO function enable /disable pin
4,13	GND	O	GND pin
5,7,9,10,14,16,23,24	N.C.	-	Non-connection
6	VDD	I	Power supply input pin
8	LDO5V	O	5V LDO output pin
11	PG	O	Power Good signal output pin
12	RSR	I	Gate drive strength adjustment pin
15	IN	I	Non-inverting gate drive input
33-46	D	I	GaN HEMT DRAIN pin
-	EXP	O	GaN HEMT SOURCE pin
-	C.S		Corner pin
-	C.N.C		Corner pin, Non-connection

Revision History

Date	Rev.	Changes
1.June.2023	001	New Release