

DRAWING FOR REFERENCE: This is subject to change without notice
08/11/2012

TO
RF

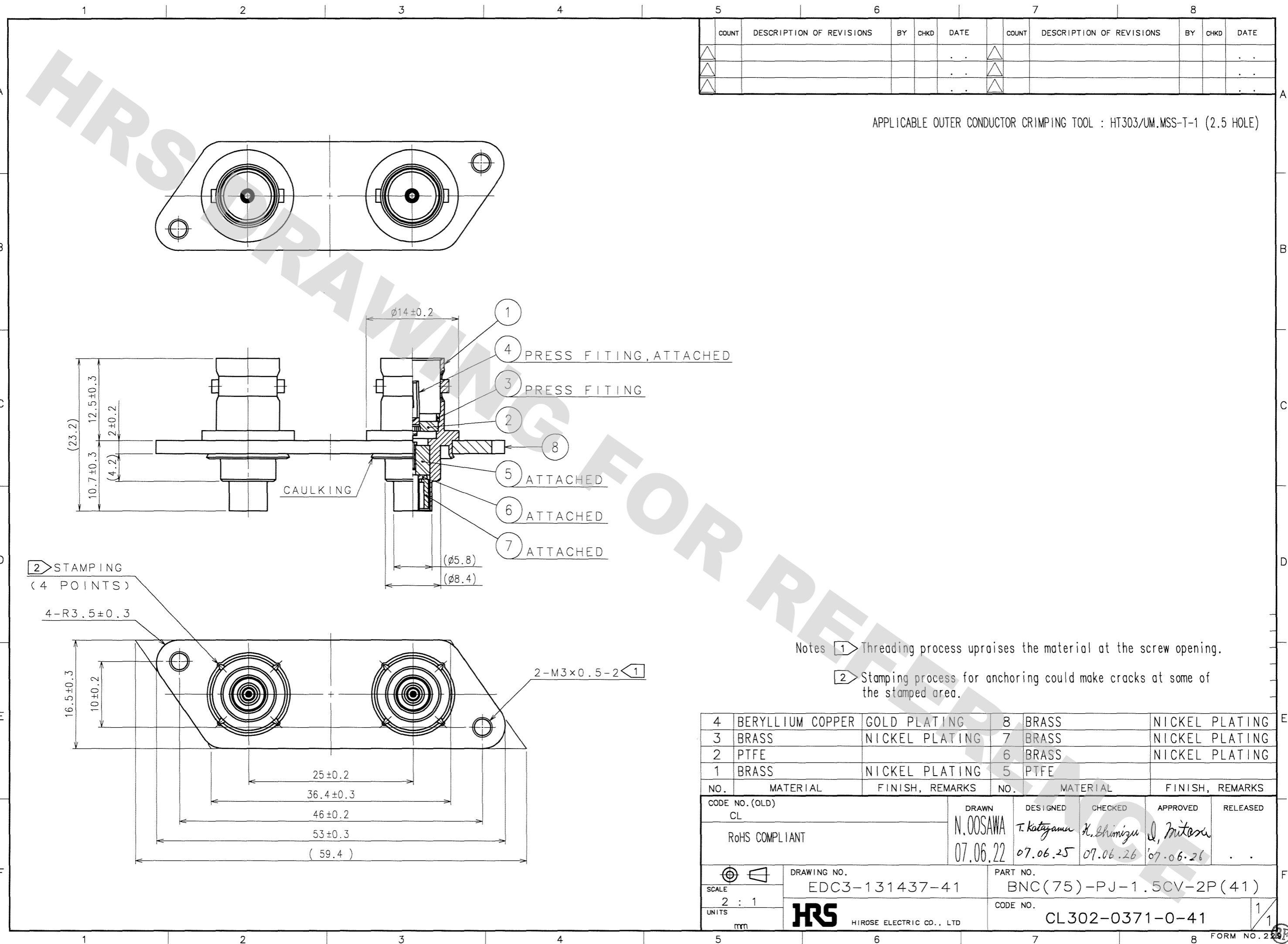

COUNT	DESCRIPTION OF REVISIONS	BY	CHKD	DATE	COUNT	DESCRIPTION OF REVISIONS	BY	CHKD	DATE

APPLICABLE OUTER CONDUCTOR CRIMPING TOOL : HT303/UM.MSS-T-1 (2.5 HOLE)

- 1 PRESS FITTING, ATTACHED
- 2 PRESS FITTING
- 3 ATTACHED
- 4 ATTACHED
- 5 ATTACHED
- 6 ATTACHED
- 7 ATTACHED
- 8

Notes 1 Threading process upraises the material at the screw opening.
2 Stamping process for anchoring could make cracks at some of the stamped area.

NO.	MATERIAL	FINISH, REMARKS	NO.	MATERIAL	FINISH, REMARKS
4	BERYLLIUM COPPER	GOLD PLATING	8	BRASS	NICKEL PLATING
3	BRASS	NICKEL PLATING	7	BRASS	NICKEL PLATING
2	PTFE		6	BRASS	NICKEL PLATING
1	BRASS	NICKEL PLATING	5	PTFE	

CODE NO. (OLD) CL	DRAWN N.OOSAWA 07.06.22	DESIGNED T. Katayama 07.06.25	CHECKED K. Shimizu 07.06.26	APPROVED J. Mitoku 07.06.26	RELEASED
RoHS COMPLIANT					
SCALE 2 : 1	DRAWING NO. EDC3-131437-41	PART NO. BNC(75)-PJ-1.5CV-2P(41)		CODE NO. CL302-0371-0-41	
UNITS mm	HRS HIROSE ELECTRIC CO., LTD			1/1	