

## Features

- Compensated digital output
- Ultra-low pressure sensing
- Digital I<sup>2</sup>C output
- Gauge and differential types
- For use in clean, dry air and non-corrosive gas environments
- RoHS compliant\*

## Applications

Industrial:

- HVAC systems
- Process monitoring
- Packaging automation

\*\* Medical Devices (low/medium risk):

- Diagnostic equipment
- Analysis equipment

# BPS120 Series - 12 mm Digital Low Pressure Sensor

### Electrical Characteristics

Supply Voltage (V <sub>s</sub> ) .....	2.7 V minimum, 5 V typical, 5.5 V maximum
Supply Current @ 5 V .....	1.2 mA minimum, 2 mA typical, 3.5 mA maximum

### Additional Information

Click these links for more information:



### Performance Characteristics

Operating Temperature .....	-40 °C to +85 °C (-40 °F to +185 °F)
Storage Temperature .....	-55 °C to +100 °C (-67 °C to +212 °F)
Pressure Range .....	0.15 to 1.0 psi (10.3 to 68.9 mbar; 1.03 to 6.89 KPa; 4.2 to 27.7 in H <sub>2</sub> O)
Output .....	Digital I <sup>2</sup> C (1)
Effective ADC Resolution .....	13 bit
Accuracy @ 25 °C .....	±0.25 % FS
Total Error Band over 0 °C to 60 °C (+32 °F to +140 °F) .....	± 1.5 % FS
Long Term Stability .....	± 0.5 % FS
Startup Time .....	15 ms maximum
Digital Update Time .....	8.5 ms typical
Proof Pressure .....	5X full scale pressure
Burst Pressure .....	10 psi

(1) I<sup>2</sup>C address is set to (0x28). Alternative addresses are available. Consult the factory for custom options.

### Product Characteristics

Media Compatibility .....	Non-corrosive dry gasses
Moisture Sensitivity Level .....	.2
ESD Classification (HBM) .....	.2 kV
Marking .....	Partial model number, media compatibility, pressure type, pressure rating, lot code
Standard Packaging .....	250 pcs./13-inch reel
Weight .....	1.307 grams (0.046 oz)

### Transfer Function Formula

$$P_{\text{psi}} = (P_{\text{max}} - P_{\text{min}}) \cdot \left( \frac{P_{\text{counts}} - 0.1 \cdot \text{Max}}{0.8 \cdot \text{Max}} \right) + P_{\text{min}}$$

#### Where

- P<sub>psi</sub> = Measured Pressure in PSI
- P<sub>counts</sub> = Pressure Counts
- P<sub>min</sub> = Minimum Pressure
- P<sub>max</sub> = Maximum Pressure
- Max = 16384 = 14 Bits

Consult factory for custom options such as supply voltage, temperature calibration range, output range accuracy specification, and update rate.

### Basic Circuit Schematic

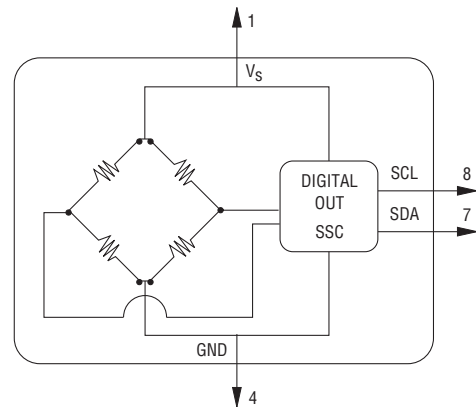

Note: Power supply decoupling included.

\* RoHS3 Directive 2015/863 Amendments of Annex II on March 31, 2015

\*\* Bourns® products have not been designed for and are not intended for use in "lifesaving," "life-critical" or "life-sustaining" applications nor any other applications where failure or malfunction of the Bourns® product may result in personal injury or death. See Legal Disclaimer Notice on the last page of this document, and at [www.bourns.com/docs/legal/disclaimer.pdf](http://www.bourns.com/docs/legal/disclaimer.pdf).

Specifications are subject to change without notice.

Users should verify actual device performance in their specific applications.

The products described herein and this document are subject to specific legal disclaimers as set forth on the last page of this document, and at [www.bourns.com/docs/legal/disclaimer.pdf](http://www.bourns.com/docs/legal/disclaimer.pdf).

# BPS120 Series - 12 mm Digital Low Pressure Sensor



## I<sup>2</sup>C Parameters

SCL Clock Frequency $f_{SCL}$ .....	100 to 400 kHz
Start Condition Hold Time Relative to SCL Edge $t_{HDSTA}$ .....	0.1 $\mu$ s
Minimum SCL Clock Low Width <sup>1</sup> $t_{LOW}$ .....	0.6 $\mu$ s
Minimum SCL Clock High Width <sup>1</sup> $t_{HIGH}$ .....	0.6 $\mu$ s
Start Condition Setup Time Relative to SCL Edge $t_{SUSTA}$ .....	0.1 $\mu$ s
Data Hold Time on SDA Relative to SCL Edge $t_{HDDAT}$ .....	0.0 $\mu$ s
Data Setup Time on SDA Relative to SCL Edge $t_{SUDAT}$ .....	0.1 $\mu$ s
Stop Condition Setup Time on SCL $t_{SUSTO}$ .....	0.1 $\mu$ s
Bus Free Time Between Stop Condition and Start Condition $t_{BUS}$ .....	2 $\mu$ s

<sup>1</sup> Combined low and high widths must equal or exceed minimum SCLK period.

## I<sup>2</sup>C Parameters

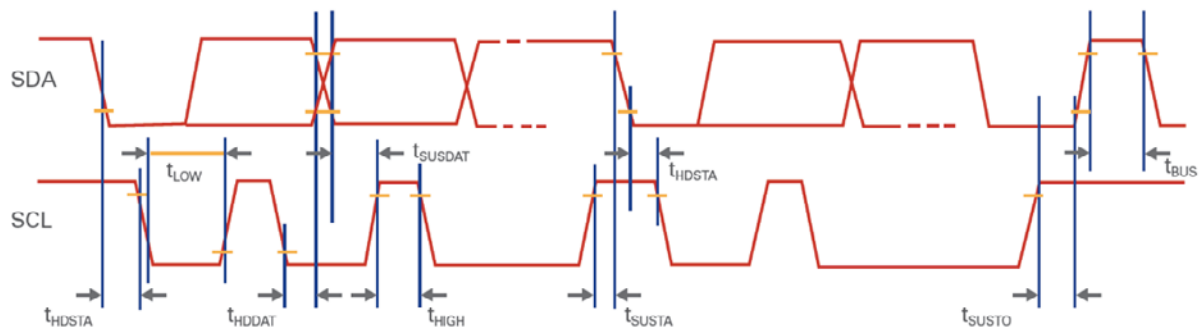

Used by permission, ZMDI

## I<sup>2</sup>C Communication

Communication to the Model BPS120 is read only. To read the pressure counts, the master performs a read request by asserting a start condition, sending the 7-bit address of the part (0x28), and sets the read/write bit. The master then waits for an acknowledgement. The acknowledgement is sent by the pressure sensor along with 2 bits of status and bits 13:8 of the pressure counts, the master acknowledges the first 8 bits, and the pressure sensor sends the remaining 8 bits of data. The master then does not acknowledge and sends a stop condition, signaling the end of the transaction.

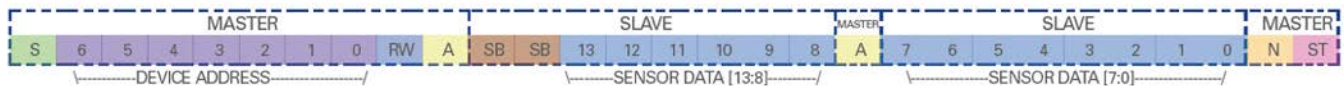

<b>S</b> Start Conditioning	<b>#</b> Device Slave Address	<b>#</b> Data Bit	<b>Status Bits</b>	
<b>RW</b> Read/Write Bit	<b>A</b> Acknowledge Bit	<b>N</b> No Acknowledge Bit	0 0	Normal Operation, Good Packet
<b>ST</b> Stop Condition	<b>SB</b> Status Bits		0 1	Device in Command Mode
			1 0	Stale Data
			1 1	Diagnostic Condition Exists

Specifications are subject to change without notice.

Users should verify actual device performance in their specific applications.

The products described herein and this document are subject to specific legal disclaimers as set forth on the last page of this document, and at [www.bourns.com/docs/legal/disclaimer.pdf](http://www.bourns.com/docs/legal/disclaimer.pdf).

# BPS120 Series - 12 mm Digital Low Pressure Sensor

**BOURNS®**

## Cross Section

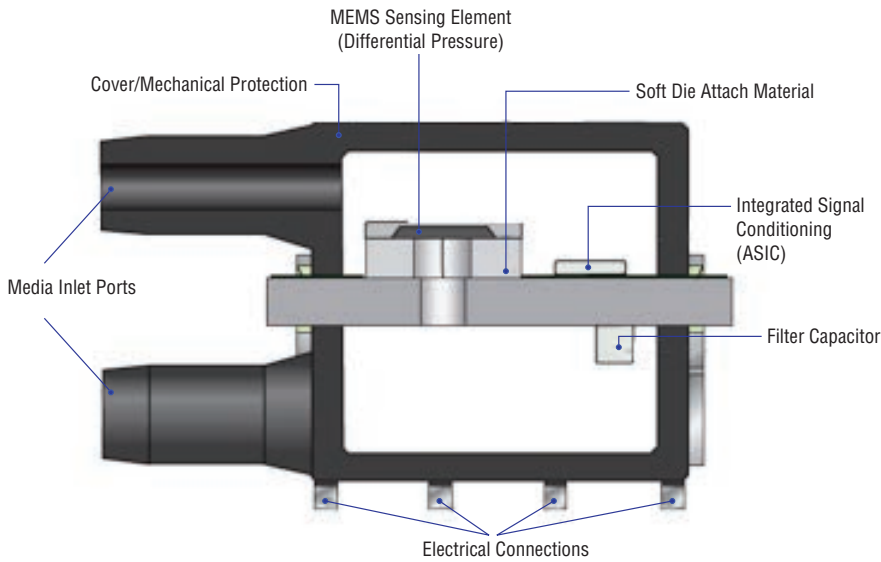

## Product Dimensions

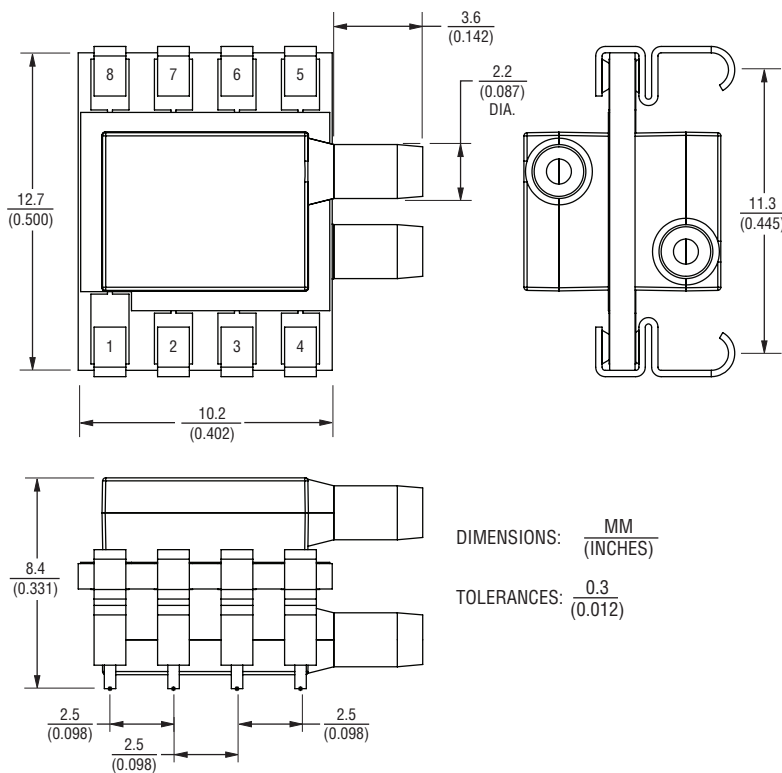

## Terminal Assignment

DEVICE PINOUT	
P1	V <sub>s</sub>
P2	N/C
P3	N/C
P4	VSS - Ground
P5	N/C
P6	N/C
P7	SDA - I <sup>2</sup> C Data
P8	SCL - I <sup>2</sup> C Clock

## Recommended PCB Layout

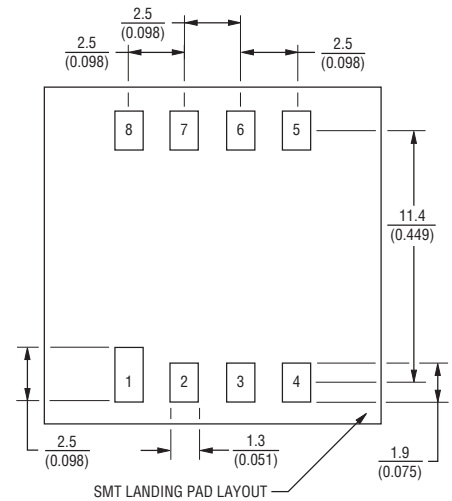

Specifications are subject to change without notice.

Users should verify actual device performance in their specific applications.

The products described herein and this document are subject to specific legal disclaimers as set forth on the last page of this document, and at [www.bourns.com/docs/legal/disclaimer.pdf](http://www.bourns.com/docs/legal/disclaimer.pdf).

# BPS120 Series - 12 mm Digital Low Pressure Sensor

**BOURNS®**

## How To Order

BPS120 - A D 0P30 - 2 D G

Model Series _____	_____	_____	_____	_____	_____	_____
Digital						
Media Compatibility _____	_____	_____	_____	_____	_____	_____
A = Air/Gas						
Pressure Type _____	_____	_____	_____	_____	_____	_____
G = Gauge						
D = Differential						
Pressure (psi) _____	_____	_____	_____	_____	_____	_____
0P15 = 0.15						
0P30 = 0.30						
01P0 = 1.0						
Terminal Pins _____	_____	_____	_____	_____	_____	_____
2 = Surface Mount Terminals						
Port Style _____	_____	_____	_____	_____	_____	_____
D = Dual Port, Horizontal						
Packaging Designator _____	_____	_____	_____	_____	_____	_____
G = 250 pcs. per 13-inch Reel						

## Solder Profile

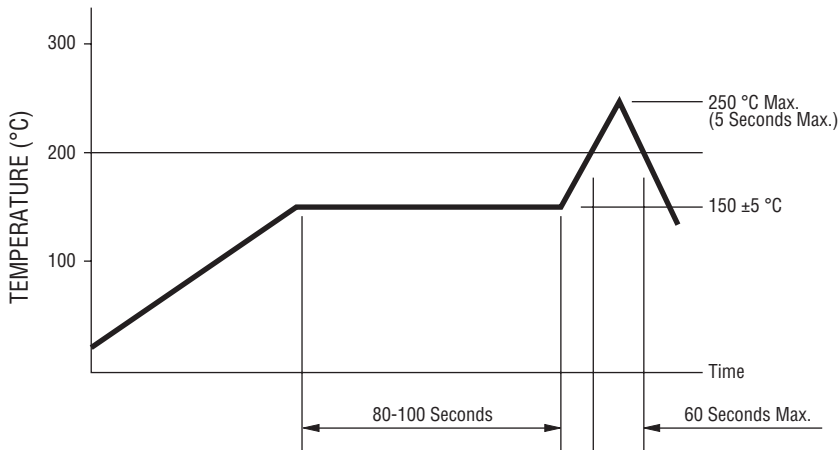

Processing Method: Reflow soldering with infrared heat or forced air convection (only once).

### Notes:

1. No clean solder paste is recommended.
2. Aqueous wash is not recommended.
3. Use of water soluble soldering flux should be avoided due to possible corrosion.
4. Multiple passes through the soldering process is not recommended.
5. Other SMD processes and profiles should be verified by the customer.

Specifications are subject to change without notice.

Users should verify actual device performance in their specific applications.

The products described herein and this document are subject to specific legal disclaimers as set forth on the last page of this document, and at [www.bourns.com/docs/legal/disclaimer.pdf](http://www.bourns.com/docs/legal/disclaimer.pdf).

# BPS120 Series - 12 mm Digital Low Pressure Sensor

**BOURNS®**

## Packaging Specification

250 pieces per 13-inch reel.  
Meets specifications of EIA-481-1 or EIA-481-2.

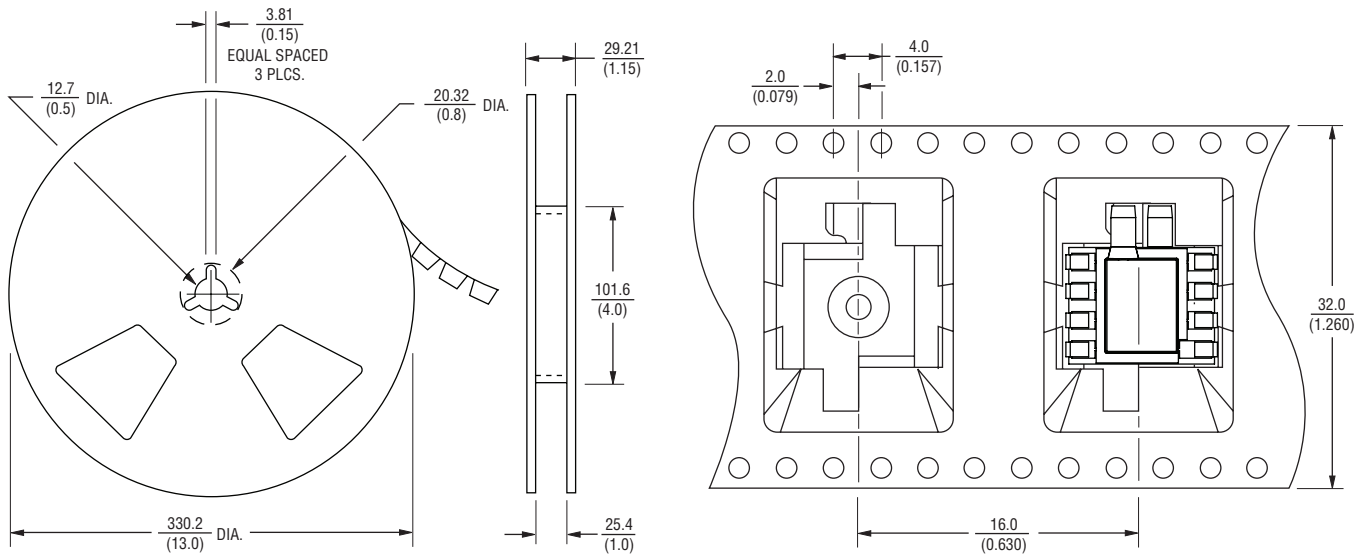

DIMENSIONS:  $\frac{\text{MM}}{\text{(INCHES)}}$

TOLERANCES:  $\frac{0.25}{(0.010)}$

**BOURNS®**

**Asia-Pacific:** Tel: +886-2 2562-4117 • Email: asiacus@bourns.com

**EMEA:** Tel: +36 88 885 877 • Email: eurocus@bourns.com

**The Americas:** Tel: +1-951 781-5500 • Email: americus@bourns.com

[www.bourns.com](http://www.bourns.com)

REV. 08/21

Specifications are subject to change without notice.

Users should verify actual device performance in their specific applications.

The products described herein and this document are subject to specific legal disclaimers as set forth on the last page of this document, and at [www.bourns.com/docs/legal/disclaimer.pdf](http://www.bourns.com/docs/legal/disclaimer.pdf).