

SINGLE-PHASE SILICON BRIDGE RECTIFIER

VOLTAGE RANGE 50 to 1000 Volts CURRENT 10 Amperes

FEATURES

- * Surge overload rating: 200 amperes peak
- * Low forward voltage drop

MECHANICAL DATA

- * UL listed the recognized component directory, file #E94233
- * Epoxy: Device has UL flammability classification 94V-O
- * Lead: Mil-STD-202E method 208C guaranteed
- * Mounting position: Any
- * Weight: 7.86 grams

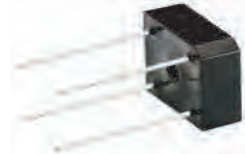

BR-10

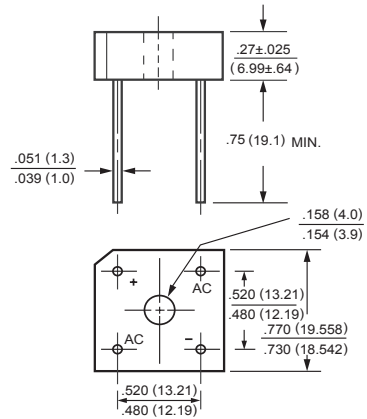

Dimensions in inches and (millimeters)

MAXIMUM RATINGS AND ELECTRICAL CHARACTERISTICS

Ratings at 25 °C ambient temperature unless otherwise specified.
Single phase, half wave, 60 Hz, resistive or inductive load.
For capacitive load, derate current by 20%.

MAXIMUM RATINGS (At TA = 25°C unless otherwise noted)

RATINGS	SYMBOL	BR1005	BR101	BR102	BR104	BR106	BR108	BR1010	UNITS	
Maximum Recurrent Peak Reverse Voltage	V _{RRM}	50	100	200	400	600	800	1000	Volts	
Maximum RMS Voltage	V _{RMS}	35	70	140	280	420	560	700	Volts	
Maximum DC Blocking Voltage	V _{DC}	50	100	200	400	600	800	1000	Volts	
Maximum Average Forward Tc = 50°C	I _O	10.0							Amps	
Peak Forward Surge Current 8.3 ms single half sine-wave superimposed on rated load (JEDEC method)	I _{FSM}					200				Amps
Current Squared Time	I ² t					166				A ² /Sec
Operating Temperature Range	T _J					-55 to + 150				°C
Storage Temperature Range	T _{STG}					-55 to + 150				°C

ELECTRICAL CHARACTERISTICS (At TA = 25°C unless otherwise noted)

CHARACTERISTICS	SYMBOL	BR1005	BR101	BR102	BR104	BR106	BR108	BR1010	UNITS	
Maximum Forward Voltage Drop per element at 5.0A DC	V _F					1.1				Volts
Maximum Reverse Current at Rated	I _R					5.0				uAmps
DC Blocking Voltage per element						0.2				mAmps

- NOTES : 1. Thermal Resistance : Mounted on PCB.
2. "Fully ROHS compliant", "100% Sn plating (Pb-free)".
3. Available in Halogen-free epoxy by adding suffix -HF after the part nbr.

RATING AND CHARACTERISTIC CURVES (BR1005 THRU BR1010)

FIG. 1 - MAXIMUM NON-REPETITIVE FORWARD SURGE CURRENT

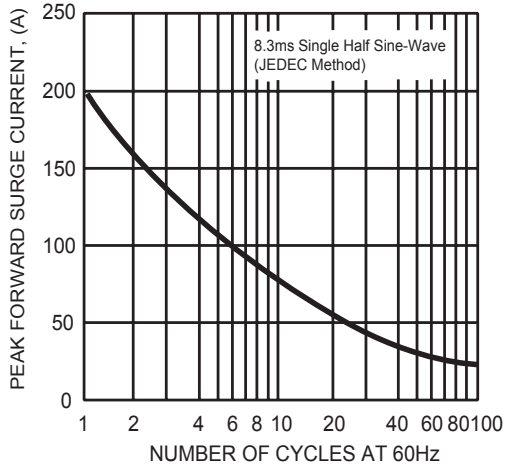

FIG. 2 - TYPICAL FORWARD CURRENT DERATING CURVE

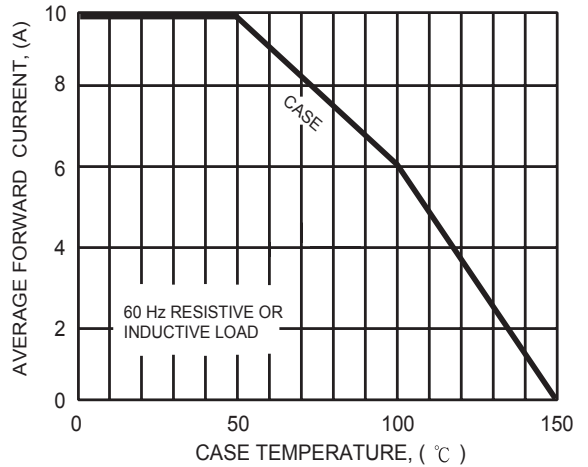

FIG. 3 - TYPICAL INSTANTANEOUS FORWARD CHARACTERISTICS

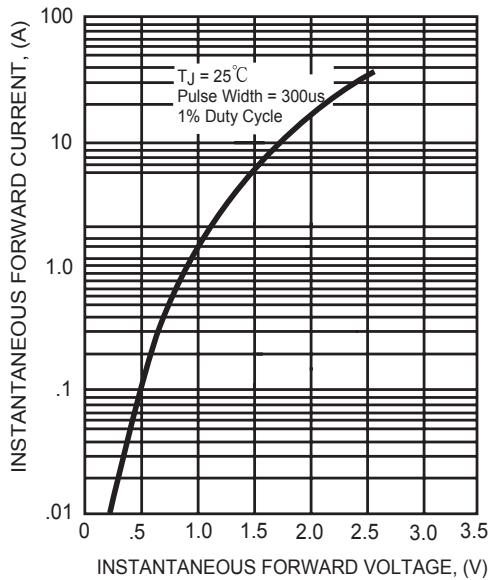
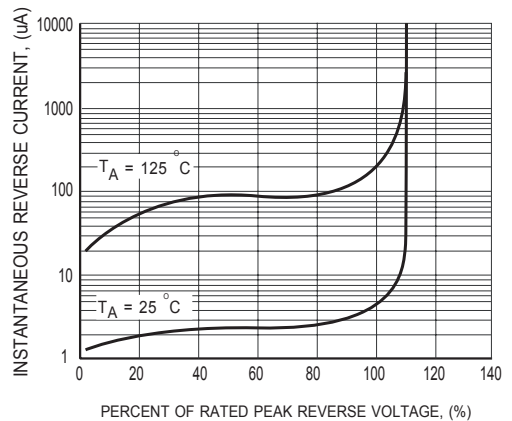

FIG. 4 - TYPICAL REVERSE CHARACTERISTICS





RECTRON

Attachment information about BR10X

1. Internal Circuit

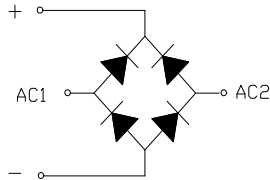

2. Marking on the body

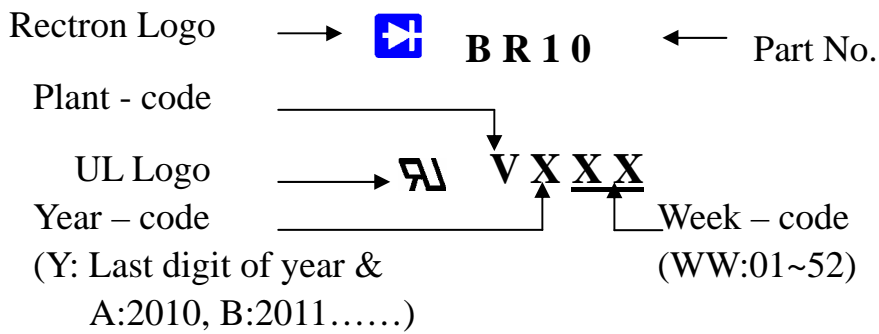

3. Items marked on the inner box and carton

3.1 On the box (for -B)

CUSTOMER
TYPE
LOT NO.
QUANTITY
Q.A.
DATE

3.2 On the carton

CUSTOMER
TYPE
QUANTITY
LOT NO.
REMARK

PACKAGING OF DIODE AND BRIDGE RECTIFIERS

BULK PACK

PACKAGE	PACKING CODE	EA PER BOX	INNER BOX SIZE (mm)	CARTON SIZE (mm)	EA PER CARTON	GROSS WEIGHT(Kg)
BR-10	-B	200	236*236*50	497*251*282	2,000	12.24