

# Boron BRN404X datasheet

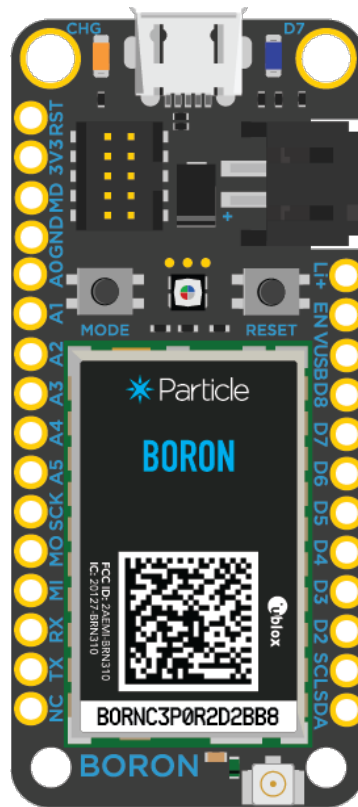

# Functional description

## OVERVIEW

---

The Boron is a powerful LTE Cat M1 enabled development kit that supports cellular networks and Bluetooth LE (BLE). It is based on the Nordic nRF52840 and has built-in battery charging circuitry so it's easy to connect a Li-Po and deploy your local network in minutes.

The Boron is great for connecting existing projects to the Particle Device Cloud where Wi-Fi is missing or unreliable.

## FEATURES

---

### Features - BRN404X (Boron LTE)

- u-blox SARA-R510S-01B LTE modem
- LTE Cat M1 module
- Support for United States, Canada, and Mexico only
- 3GPP Release 14 LTE Cat M1
- Cat M1 bands: 1, 2, 3, 4, 5, 8, 12, 13, 18, 19, 20, 25, 26, 28, 66, 71, 85<sup>1</sup>
- Embedded Particle EtherSIM
- Requires Device OS 4.0.0 LTS (or later)

<sup>1</sup> Not all bands enabled in software by default

### Features - All Models

- Nordic Semiconductor nRF52840 SoC
- ARM Cortex-M4F 32-bit processor @ 64MHz
- 1MB flash, 256KB RAM
- Bluetooth 5: 2 Mbps, 1 Mbps, 500 Kbps, 125 Kbps
- Supports DSP instructions, HW accelerated Floating Point Unit (FPU) and encryption functions
- Up to +8 dBm TX power (down to -20 dBm in 4 dB steps)
- NFC-A tag
- On-board additional 4MB SPI flash
- 20 mixed signal GPIO (6 x Analog, 8 x PWM), UART, I2C, SPI
- Micro USB 2.0 full speed (12 Mbps)
- Integrated Li-Po charging and battery connector
- JTAG (SWD) Connector
- RGB status LED
- Reset and Mode buttons
- Dual SIM support: Nano 4FF and MFF2
- On-board PCB antenna
- U.FL connector for external antenna
- Meets the Adafruit Feather [specification](#) in dimensions and pinout
- FCC and PTCRB certified
- RoHS compliant (lead-free)

# Interfaces

## BLOCK DIAGRAM

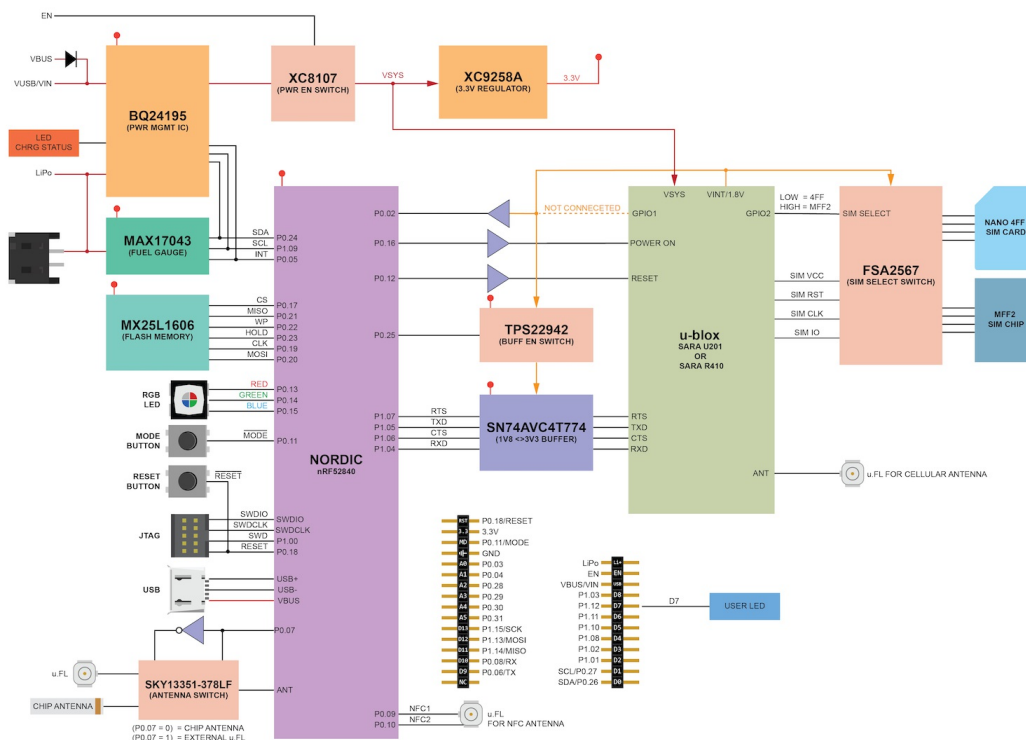

## POWER

### USB PORT

The USB port is the easiest way to power up the Boron. Please make sure that the USB port is able to provide at least 500mA. Power from the USB is regulated down to 3.3V by the on board Torex XC9258A step-down regulator.

### VUSB PIN

The pin is internally connected to the VBUS of the USB port. The nominal output should be around 4.5 to 5 VDC when the device is plugged into the USB port and 0 when not connected to a USB source. You can use this pin to power peripherals that operate at such voltages. Do not exceed the current rating of the USB port, which is nominally rated to 500mA.

### LiPo

If you want to make your projects truly wireless, you can power the device with a single cell LiPo (3.7V). The Boron has an on board LiPo charger that will charge and power the device when USB source is plugged in, or power the device from the LiPo alone in the absence of the USB.

**NOTE:** Please pay attention to the polarity of the LiPo connector. Not all LiPo batteries follow the same polarity convention!

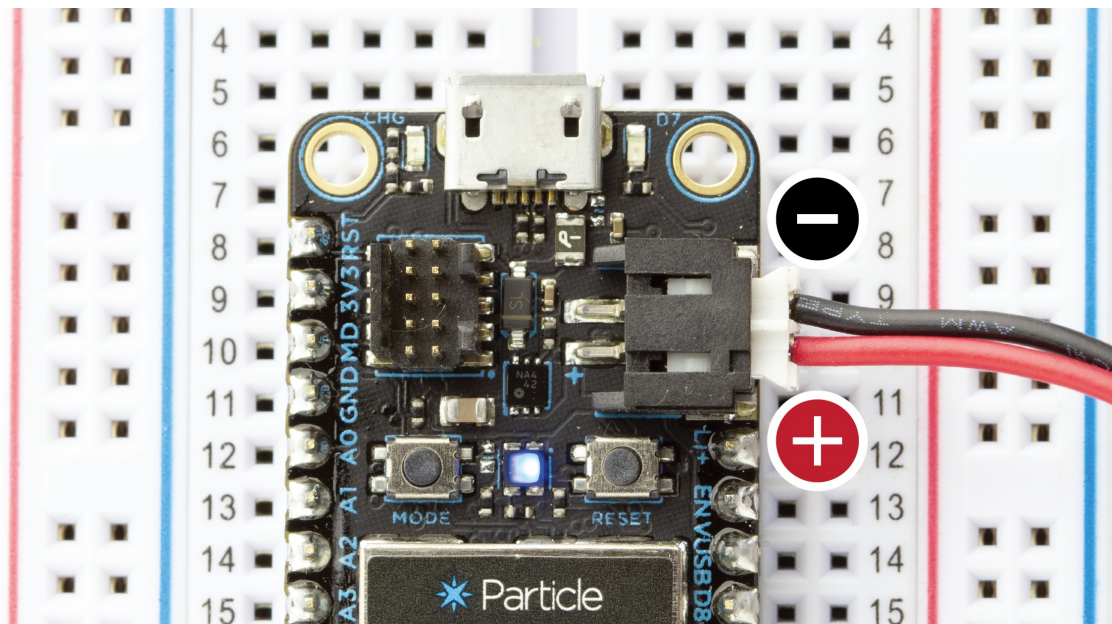

### Li+ PIN

This pin is internally connected to the positive terminal of the LiPo connector. You can connect a single cell LiPo/Lithium Ion or a DC supply source to this pin for powering the Boron. Remember that the input voltage range on this pin is 3.6 to 4.2 VDC.

### 3V3 PIN

This pin is the output of the on board 3.3V step-down switching regulator (Torex XC9258A). The regulator is rated at 1000mA max. When using this pin to power other devices or peripherals remember to budget in the current requirement of the Boron first. Unlike the Photon, this pin **CANNOT** be used to power the Boron.

### EN PIN

The **EN** pin is not a power pin, per se, but it controls the 3V3 and cellular modem power via a load switch (XC8107, U2). The EN pin is pulled high by a 100K resistor to PMIC\_SYS (3.8V), which is powered by VUSB, the micro USB connector, or the LiPo battery. Because the pull-up can result in voltages above 3.3V you should never directly connect EN to a 3.3V GPIO pin. Instead, you should only pull EN low, such as by using an N-channel MOSFET or other open-collector transistor.

The EN pin can force the device into a deep power-down state where it uses very little power. It also can be used to assure that the device is completely reset, similar to unplugging it, with one caveat:

If using the EN pin to deeply reset the device, you must be careful not to allow leakage current back into the nRF52 MCU by GPIO or by pull-ups to 3V3. If you only power external devices by 3V3 you won't run into this, as 3V3 is de-powered when EN is low.

However, if you have circuitry that is powered by a separate, external power supply, you must be careful. An externally powered circuit that drives a nRF52 GPIO high when EN is low can provide enough current to keep the nRF52 from powering down and resetting. Likewise, a pull-up to an external power supply can do the same thing. Be sure that in no circumstances can power be supplied to the nRF52 when 3V3 is de-powered.

[See the power supply schematic](#), below, for more information.

## ANTENNA

---

There are two radios on the Boron. A BLE radio (nRF52840) and a cellular radio (u-blox). For the cellular radio, we have provided a u.FL connector to plug in the cellular antenna. This is required if you wish to use the cellular connectivity.

There are two options for the BLE antenna on the Boron. It comes with an on-board PCB antenna which is selected by default in the device OS and a u.FL connector if you wish to connect an external antenna. If you wish to use the external antenna, you'll need to issue an appropriate command in the firmware.

## FCC APPROVED ANTENNAS

---

### BLE

The following antenna is optional, as the Boron comes with an on-board chip antenna for BLE. It can be purchased in the [Particle online store](#).

Particle Device	Frequency	Antenna Type	Manufacturer	MFG. Part #	Gain
Boron	2400-2500 MHz	PCB Antenna	Particle	ANT-FLXV2	2.0dBi peak

It is also possible to use most antennas designed for Wi-Fi (2.4 GHz) as a BLE antenna. In some cases, a u.FL to RP-SMA adapter will be required. If you are building a product using alternative antennas, additional certification may be required.

### Cellular

Antenna	SKU	Details	Links
Wide band LTE-CAT M1 cell antenna, [x1]	PARANTC41EA	B404X, BRN404X, and E404X	<a href="#">Datasheet</a>
Wide band LTE-CAT M1 cell antenna, [x50]	PARANTC41TY	B404X, BRN404X, and E404X	<a href="#">Datasheet</a>

## PERIPHERALS AND GPIO

---

Peripheral Type	Qty	Input(I) / Output(O)
Digital	20	I/O
Analog (ADC)	6	I
UART	1	I/O
SPI	1	I/O
I2C	2	I/O
USB	1	I/O
PWM	8	O

**Note:** All GPIOs are only rated at 3.3VDC max.

## SWD

---

The Boron has a dedicated 10 pin debug connector that exposes the SWD interface of the nRF52840. This interface can be used to debug your code or reprogram your Boron bootloader, device OS, or the user firmware using any standard SWD tools including our Gen 3 Debugger.

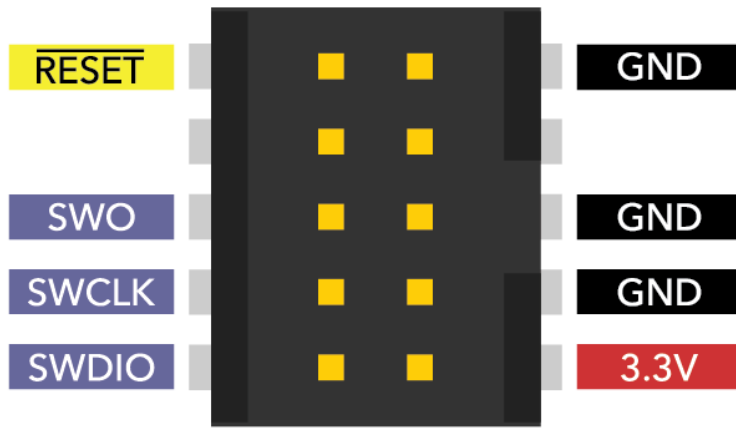

# Memory map

## **NRF52840 FLASH LAYOUT OVERVIEW**

---

- Bootloader (48KB, @0xF4000)
- User Application
  - 256KB @ 0xB4000 (Device OS 3.1 and later)
  - 128KB @ 0xD4000 (Device OS 3.0 and earlier)
- System (656KB, @0x30000)
- SoftDevice (192KB)

## **EXTERNAL SPI FLASH LAYOUT OVERVIEW (DFU OFFSET: 0X80000000)**

---

- OTA (1500KB, @0x00289000)
- Reserved (420KB, @0x00220000)
- FAC (128KB, @0x00200000)
- LittleFS (2M, @0x00000000)

# Pins and button definitions

## PIN MARKINGS

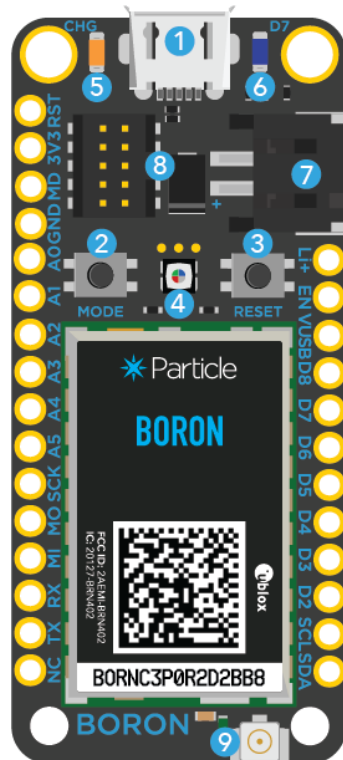

- 1 USB
- 2 MODE BUTTON
- 3 RESET BUTTON
- 4 RGB STATUS LED
- 5 CHARGE STATUS LED
- 6 USER LED (ON D7)
- 7 LiPo BATT CONNECTOR
- 8 DEBUG CONNECTOR (SWD)
- 9 u.FL CONNECTOR FOR CELLULAR ANTENNA (REQUIRED)

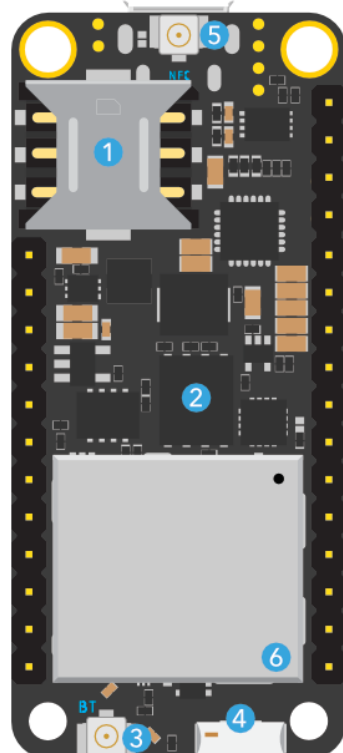

- 1 NANO SIM HOLDER
- 2 ON-BOARD MFF2 SIM
- 3 u.FL CONNECTOR FOR EXTERNAL MESH ANTENNA (OPTIONAL)
- 4 ON-BOARD CHIP ANTENNA FOR MESH
- 5 u.FL CONNECTOR FOR NFC ANTENNA
- 6 RF SHIELD

## PINOUT DIAGRAM



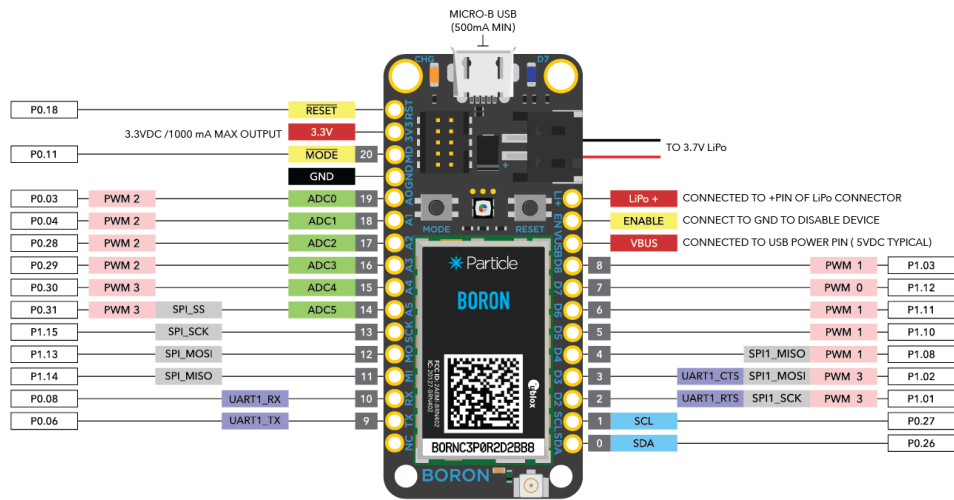

<span style="background-color: #f8d7da; padding: 2px;">PWM 0</span> GROUP 0 PWM PINS	<span style="background-color: #d4edda; padding: 2px;">ADC</span> ANALOG TO DIGITAL INPUT PINS	<span style="background-color: #d1ecf1; padding: 2px;">UART1</span> SERIAL COMMUNICATION PINS (SERIAL1)
<span style="background-color: #f8d7da; padding: 2px;">PWM 1</span> GROUP 1 PWM PINS	<span style="background-color: #d4edda; padding: 2px;">SPI</span> SPI COMMUNICATION PINS (SPI)	<span style="background-color: #d1ecf1; padding: 2px;">SPI1</span> SPI COMMUNICATION PINS (SPI1)
<span style="background-color: #f8d7da; padding: 2px;">PWM 2</span> GROUP 2 PWM PINS	<span style="background-color: #d4edda; padding: 2px;">SDA/SCL</span> I2C COMMUNICATION PINS (WIRE)	
<span style="background-color: #f8d7da; padding: 2px;">PWM 3</span> GROUP 3 PWM PINS	<span style="border: 1px solid black; padding: 2px;">PX.XX</span> nRF52840 PIN NAMES	

v1.0

You can download a high resolution [PDF version of the pin out here.](#)

## PIN DESCRIPTION

Pin	Description
Li+	This pin is internally connected to the positive terminal of the LiPo battery connector.
VUSB	This pin is internally connected to the USB (+ve) supply.
3V3	This pin is the output of the on-board 3.3V regulator.
GND	System ground pin.
EN	Device enable pin is internally pulled-up. To disable the device, connect this pin to GND.
RST	Active-low system reset input. This pin is internally pulled-up.
MD	This pin is internally connected to the MODE button. The MODE function is active-low.
RX	Primarily used as UART RX, but can also be used as a digital GPIO.
TX	Primarily used as UART TX, but can also be used as a digital GPIO.
SDA	Primarily used as data pin for I2C, but can also be used as a digital GPIO.
SCL	Primarily used as clock pin for I2C, but can also be used as a digital GPIO.
MO,MI,SCK	These are the SPI interface pins, but can also be used as a digital GPIO.
D2-D8	These are generic GPIO pins. D2-D8 are PWM-able.
A0-A5	These are analog input pins that can also act as standard digital GPIO. A0-A5 are PWM-able.

## GPIO AND PORT LISTING

---

Pin Name		MCU
A0 / D19	ADC0	P0.3
A1 / D18	ADC1	P0.4
A2 / D17	ADC2	P0.28
A3 / D16	ADC3	P0.29
A4 / D15	ADC4	P0.30
A5 / D14	ADC5	SPI (SS) P0.31
D0	Wire (SDA)	P0.26
D1	Wire (SCL)	P0.27
D2	SPI1 (SCK)	Serial11 RTS P1.01
D3	SPI1 (MOSI)	Serial11 CTS P1.02
D4	SPI1 (MISO)	P1.08
D5		P1.10
D6		P1.11
D7		P1.12
D8 / WKP		P1.03
MISO / D11	SPI (MISO)	P1.14
MOSI / D12	SPI (MOSI)	P1.13
RX / D10		Serial11 RX P0.08
SCK / D13	SPI (SCK)	P1.15
TX / D09		Serial11 TX P0.06

## ADC (ANALOG TO DIGITAL CONVERTER)

---

The Boron supports 6 ADC inputs.

Pin Name	Description	Interface	MCU
A0 / D19	A0 Analog in, GPIO, PWM	ADC0	P0.3
A1 / D18	A1 Analog in, GPIO, PWM	ADC1	P0.4
A2 / D17	A2 Analog in, GPIO, PWM	ADC2	P0.28
A3 / D16	A3 Analog in, GPIO, PWM	ADC3	P0.29
A4 / D15	A4 Analog in, GPIO, PWM	ADC4	P0.30
A5 / D14	A5 Analog in, GPIO, PWM, SPI SS	ADC5	P0.31

- ADC inputs are single-ended and limited to 0 to 3.3V
- Resolution is 12 bits

## UART SERIAL

---

The Boron supports one UART serial interface.

Pin Name	Description	Interface	MCU
RX / D10	Serial RX, GPIO	Serial11 RX	P0.08
TX / D09	Serial TX, GPIO	Serial11 TX	P0.06
D2	SPI1 SCK, Serial11 RTS, GPIO, PWM	Serial11 RTS	P1.01
D3	SPI1 MOSI, Serial11 CTS, PWM, GPIO	Serial11 CTS	P1.02

- The UART pins are 3.3V and must not be connected directly to a RS-232C port or to a 5V TTL serial port
- Hardware flow control is optional; if not used then the RTS and CTS pins can be used as regular GPIO
- You cannot use hardware flow control and Ethernet at the same time.

## SPI

---

The Boron supports two SPI (serial peripheral interconnect) ports.

Pin Name	Description	Interface	MCU
A5 / D14	A5 Analog in, GPIO, PWM, SPI SS	SPI (SS)	P0.31
SCK / D13	SPI SCK, GPIO	SPI (SCK)	P1.15
MOSI / D12	SPI MOSI, GPIO	SPI (MOSI)	P1.13
MISO / D11	SPI MISO, GPIO	SPI (MISO)	P1.14
D2	SPI1 SCK, Serial11 RTS, GPIO, PWM	SPI1 (SCK)	P1.01
D3	SPI1 MOSI, Serial11 CTS, PWM, GPIO	SPI1 (MOSI)	P1.02
D4	SPI1 MISO, PWM, GPIO	SPI1 (MISO)	P1.08

- The SPI port is 3.3V and must not be connected directly to devices that drive MISO at 5V
- If not using a SPI port, its pins can be used as GPIO
- Any pins can be used as the SPI chip select
- Multiple devices can generally share a single SPI port
- You cannot use SPI1 and Ethernet at the same time.

## I2C

---

The Boron supports one I2C (two-wire serial interface) port.

Pin Name	Description	Interface	MCU
D0	I2C SDA, GPIO	Wire (SDA)	P0.26
D1	I2C SCL, GPIO	Wire (SCL)	P0.27

- The I2C port is 3.3V and must not be connected directly a 5V I2C bus
- Maximum bus speed is 400 kHz
- External pull-up resistors are recommended for I2C as the internal pull-up is 13K.
- If not using I2C, pins D0 and D1 can be used as GPIO or analog input.

## PWM

---

The Boron supports PWM (pulse-width modulation) on the following pins:

Pin Name	Description	Timer	MCU
A0 / D19	A0 Analog in, GPIO, PWM	PWM2	P0.3
A1 / D18	A1 Analog in, GPIO, PWM	PWM2	P0.4
A2 / D17	A2 Analog in, GPIO, PWM	PWM2	P0.28
A3 / D16	A3 Analog in, GPIO, PWM	PWM2	P0.29
A4 / D15	A4 Analog in, GPIO, PWM	PWM3	P0.30
A5 / D14	A5 Analog in, GPIO, PWM, SPI SS	PWM3	P0.31
D2	SPI1 SCK, Serial11 RTS, GPIO, PWM	PWM3	P1.01

D3	SPI1 MOSI, Serial1 CTS, PWM, GPIO	PWM3	P1.02
D4	SPI1 MISO, PWM, GPIO	PWM1	P1.08
D5	PWM, GPIO	PWM1	P1.10
D6	PWM, GPIO	PWM1	P1.11
D7	PWM, GPIO	PWM0	P1.12
D8 / WKP	GPIO, PWM	PWM1	P1.03

- PWM that share the same timer (**PMW2** for example) must share the same frequency but can have different duty cycles.
- Pin D7 (PWM0) share a timer with the RGB LED and you should not change its frequency but it can have a different duty cycle.

### System RGB LED

For a detailed explanation of different color codes of the RGB system LED, please take a look [here](#).

### Charge status LED

State	Description
ON	Charging in progress
OFF	Charging complete
Blink at 1Hz	Fault condition <sup>[1]</sup>
Rapid blinking	Battery disconnected <sup>[2]</sup>

#### Notes:

<sup>[1]</sup> A fault condition can occur due to several reasons, for example, battery over/under voltage, temperature fault or safety timer fault. You can find the root cause by reading the fault register of the power management IC in firmware.

<sup>[2]</sup> You can stop this behavior by either plugging in the LiPo battery or by disabling charging using firmware command: `PMIC().disableCharging();`.

# Technical specifications

## ABSOLUTE MAXIMUM RATINGS <sup>[1]</sup>

---

Parameter	Symbol	Min	Typ	Max	Unit
Supply Input Voltage	V <sub>IN-MAX</sub>			+6.2	V
Battery Input Voltage	V <sub>LiPo</sub>			+6.5	V
Supply Output Current	I <sub>3V3-MAX-L</sub>			1000	mA
Storage Temperature	T <sub>stg</sub>	-30		+75	°C
ESD Susceptibility HBM (Human Body Mode)	V <sub>ESD</sub>			1	kV

<sup>[1]</sup> Stresses beyond those listed under absolute maximum ratings may cause permanent damage to the device. These are stress ratings only, and functional operation of the device at these or any other conditions beyond those indicated under recommended operating conditions is not implied. Exposure to absolute-maximum-rated conditions for extended periods may affect device reliability.

## RECOMMENDED OPERATING CONDITIONS

---

Parameter	Symbol	Min	Typ	Max	Unit
LiPo Battery Voltage	V <sub>LiPo</sub>	+3.3		+4.4	V
Supply Input Voltage	V <sub>3V3</sub>	+3.0	+3.3	+3.6	V
Supply Output Voltage	V <sub>3V3</sub>		+3.3		V
Operating Temperature	T <sub>op</sub>	-20		+60	°C
Humidity Range Non condensing, relative humidity				95	%

## POWER CONSUMPTION (BORON LTE)

Values are from BRN404/BRN402. Actual operating current with cellular using the R510 modem may vary but should be similar.

Parameter	Symbol	Min	Typ	Peak	Unit
Peak Current	I <sub>Li+ pk</sub>	120		490	mA
Operating Current (uC on, peripherals and radio disabled)	I <sub>idle</sub>	3.89	3.90	3.92	mA
Operating Current (uC on, cellular on but not connected)	I <sub>cell_idle</sub>		5.78	16.9	mA
Operating Current (uC on, cellular connecting to tower)	I <sub>cell_conn_twr</sub>	14.7	58.9	178	mA
Operating Current (uC on, cellular connecting to cloud)	I <sub>cell_conn_cloud</sub>	14.6	53.4	207	mA
Operating Current (uC on, cellular connected but idle)	I <sub>cell_cloud_idle</sub>		17.9	108	mA
Operating Current (uC on, cellular connected and transmitting)	I <sub>cell_cloud_tx</sub>		63.9	184	mA
STOP mode sleep, GPIO wake-up	I <sub>stop_gpio</sub>	565	575	590	uA
STOP mode sleep, analog wake-up	I <sub>stop_analog</sub>	565	577	593	uA
STOP mode sleep, RTC wake-up	I <sub>stop_intrtc</sub>	568	584	602	uA
STOP mode sleep, BLE wake-up, advertising	I <sub>stop_ble_adv</sub>	91.6	885	2210	uA
STOP mode sleep, BLE wake-up, connected	I <sub>stop_ble_conn</sub>	486	866	1440	uA
STOP mode sleep, serial wake-up	I <sub>stop_usart</sub>	569	587	612	uA
STOP mode sleep, cellular wake-up	I <sub>stop_cell</sub>		12.2	104	mA
ULP mode sleep, GPIO wake-up	I <sub>ulp_gpio</sub>		127	137	uA
ULP mode sleep, analog wake-up	I <sub>ulp_analog</sub>		130	141	uA
ULP mode sleep, RTC wake-up	I <sub>ulp_intrtc</sub>		128	138	uA
ULP mode sleep, BLE wake-up, advertising	I <sub>ulp_ble_adv</sub>		442	2120	uA
ULP mode sleep, BLE wake-up, connected	I <sub>ulp_ble_conn</sub>		438	1050	uA
ULP mode sleep, serial wake-up	I <sub>ulp_usart</sub>	568	584	601	uA
ULP mode sleep, cellular wake-up	I <sub>ulp_cell</sub>		14.2	112	mA
HIBERNATE mode sleep, GPIO wake-up	I <sub>hib_gpio</sub>	98.7	106	118	uA
HIBERNATE mode sleep, analog wake-up	I <sub>hib_analog</sub>	99.4	106	120	uA
Power disabled (EN pin = LOW)	I <sub>disable</sub>		70	75	uA

<sup>1</sup>The min, and particularly peak, values may consist of very short transients. The typical (typ) values are the best indicator of overall power consumption over time. The peak values indicate the absolute minimum capacity of the power supply necessary, not overall consumption.

## RADIO SPECIFICATIONS

---

Boron has two radio modules, the nRF52 MCU BLE radio, and a cellular module, depending on the model.

### Nordic Semiconductor nRF52840 for BLE.

Feature	Description
Operating Frequencies	2360 to 2500 MHz
Output Power	Programmable -20dBm to +8dBm
PLL channel spacing	1 MHz
On the air data rate	125 to 2000 kbps

### u-blox SARA-R510S-01B

Parameter	Value	FCC Certified
Protocol stack	3GPP Release 14	
RAT	LTE Cat M1 Half-Duplex	
LTE FDD Bands	Band 71 (600 MHz)	
	Band 12 (700 MHz)	✓
	Band 28 (700 MHz)	✓
	Band 85 (700 MHz)	
	Band 13 (750 MHz)	✓
	Band 20 (800 MHz)	✓
	Band 5 (850 MHz)	✓
	Band 18 (850 MHz)	
	Band 19 (850 MHz)	
	Band 26 (850 MHz)	
	Band 8 (900 MHz)	✓
	Band 4 (1700 MHz)	✓
	Band 3 (1800 MHz)	✓
	Band 2 (1900 MHz)	✓
	Band 25 (1900 MHz)	
	Band 1 (2100 MHz)	
Power class	Class 3 (23 dBm)	

- LTE Cat M1 for United States, Canada, and Mexico.
- Not all bands are enabled in software by default.
- FCC Certification in the United States only tests bands in use in the United States.
- Particle LTE Cat M1 devices are not certified for use in Europe or other countries that follow EU certification requirements.

## I/O CHARACTERISTICS

---

These specifications are based on the nRF52840 datasheet.

Parameter	Symbol	Conditions	Min	Typ	Max	Unit
Input high voltage	V <sub>IH</sub>		0.7*3.3	--	3.3	V
Input low voltage	V <sub>IL</sub>		0		0.3*3.3	V



Current at GND+0.4 V, output set low, high drive	$I_{OL,HDL}$	$V_{3V3} \geq 2.7V$	6	10	15	mA
Current at $V_{3V3}-0.4$ V, output set high, high drive	$I_{OH,HDH}$	$V_{3V3} \geq 2.7V$	6	9	14	mA
Current at GND+0.4 V, output set low, standard drive	$I_{OL,SD}$	$V_{3V3} \geq 2.7V$	1	2	4	mA
Current at $V_{3V3}-0.4$ V, output set high, standard drive	$I_{OH,SD}$	$V_{3V3} \geq 2.7V$	1	2	4	mA
Pull-up resistance	$R_{PU}$		11	13	16	k $\Omega$
Pull-down resistance	$R_{PD}$		11	13	16	k $\Omega$

GPIO default to standard drive (2mA) but can be reconfigured to high drive (9mA) in Device OS 2.0.0 and later using the `pinSetDriveStrength()` function.

# Mechanical specifications

## DIMENSIONS AND WEIGHT

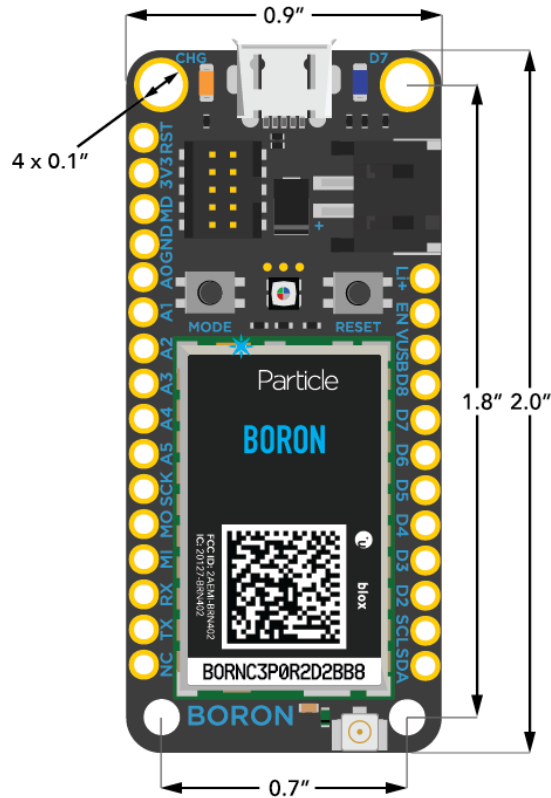

- Weight = 10 grams

## MATING CONNECTORS

The Boron uses two single row 0.1" pitch male header pins. One of them is 16 pin while the other is 12 pin. It can be mounted with matching 0.1" pitch female headers with a typical height of 0.335" (8.5mm). When you search for parts like these it can be difficult to navigate the thousands of parts available online so here are a few good choices for the Boron:

Description	MFG	MFG Part Number
16-pin 0.1" (2.54mm) Female Header	Sullins	PPTC161LFBN-RC
16-pin 0.1" (2.54mm) Female Header	TE	6-535541-4
12-pin 0.1" (2.54mm) Female Header	Sullins	PPTC121LFBN-RC
12-pin 0.1" (2.54mm) Female Header	TE	6-534237-0

# Recommended PCB land pattern

The Boron can be directly soldered onto the PCB or be mounted with the above mentioned female headers.

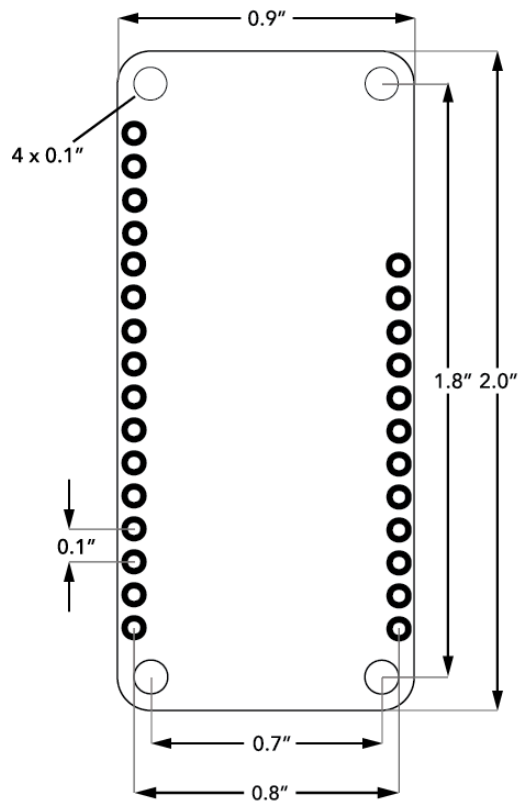

# Schematic

The complete schematic and board files are open source and available on Particle's GitHub repository [here](#).

## POWER

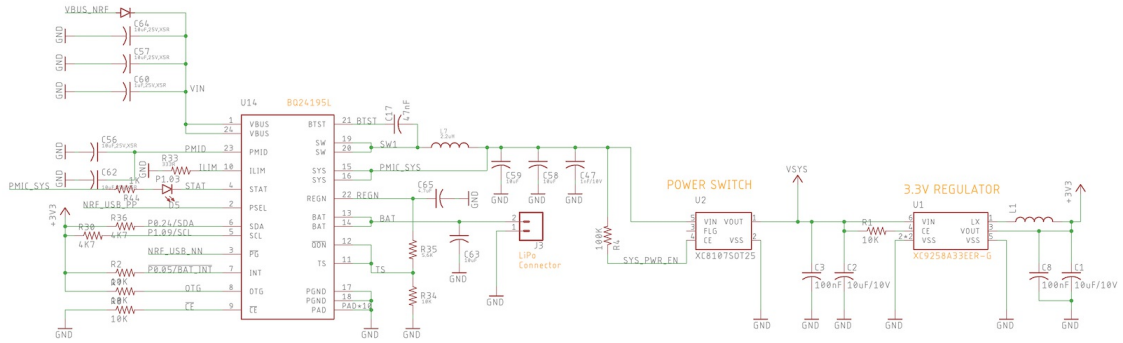

## NRF52840

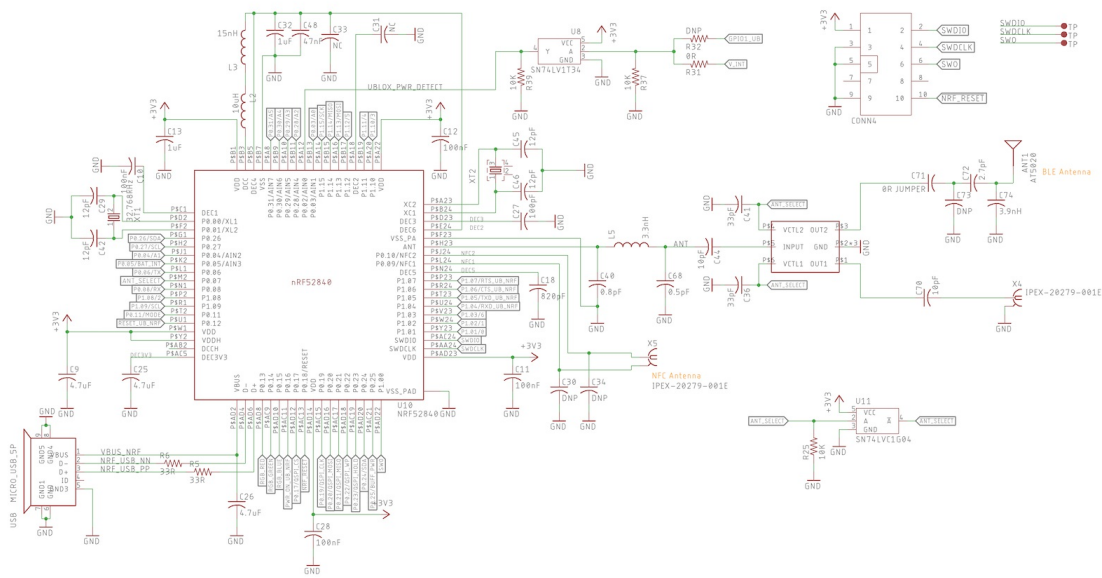

## U-BLOX

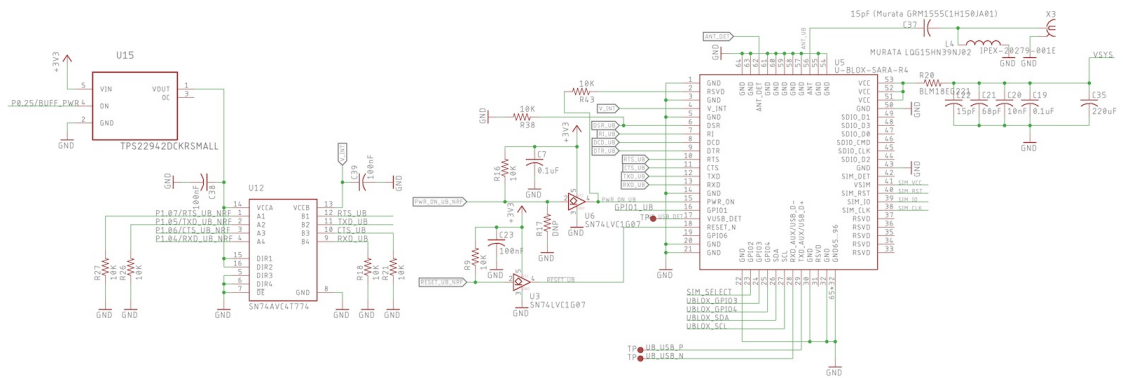

## SIM

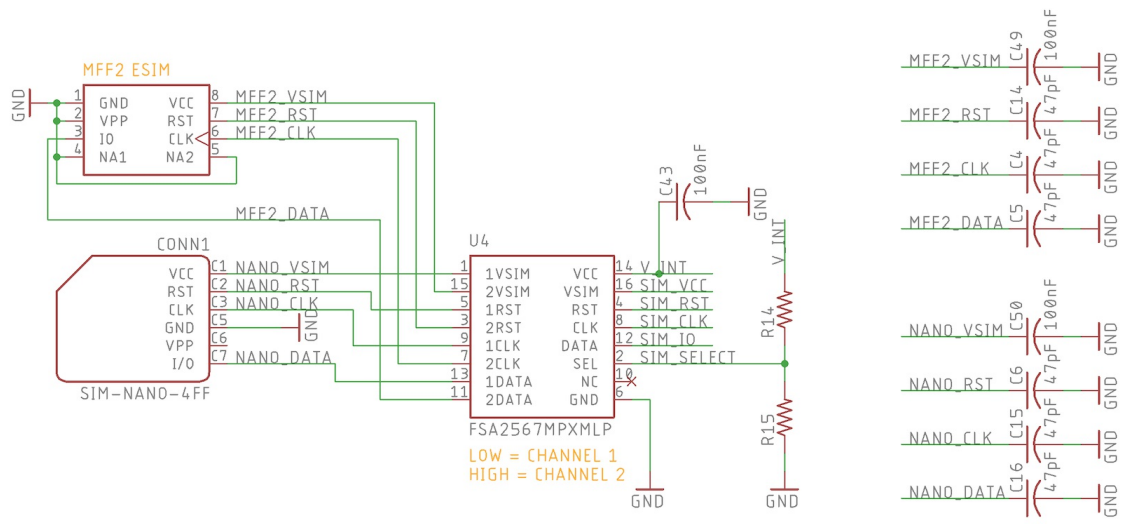

### SPI FLASH

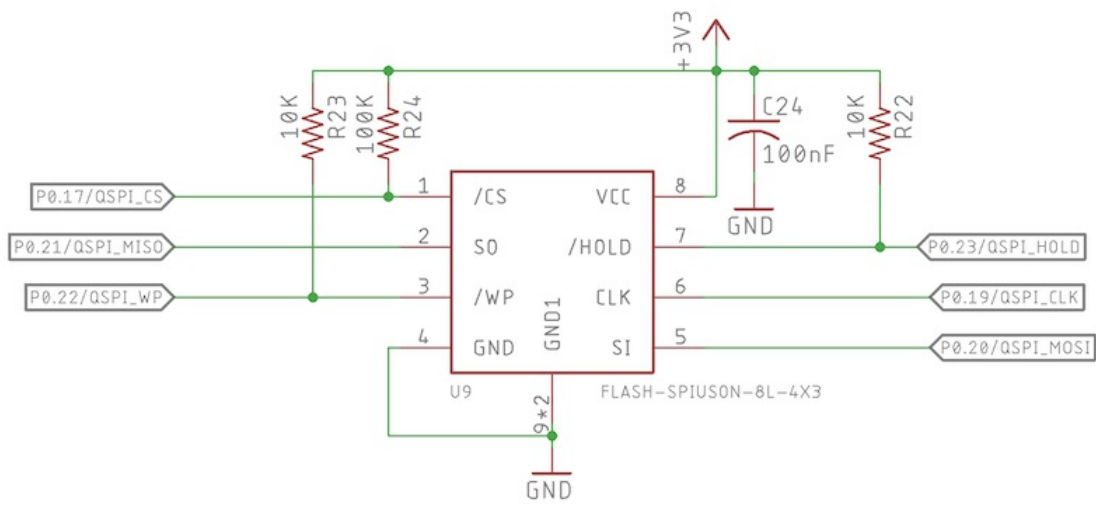

### FUEL GAUGE

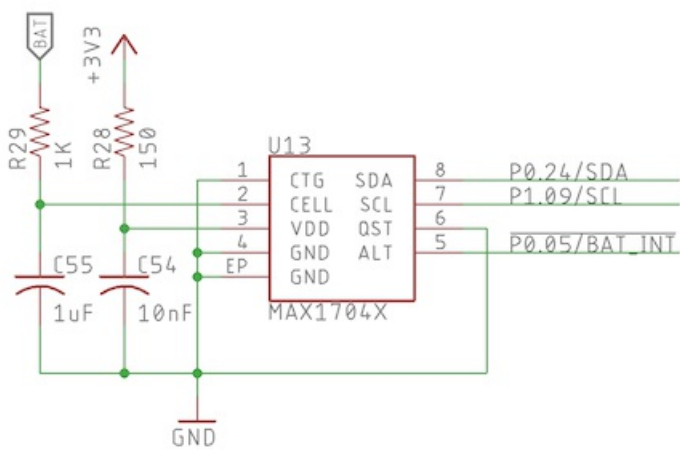

### INTERFACES

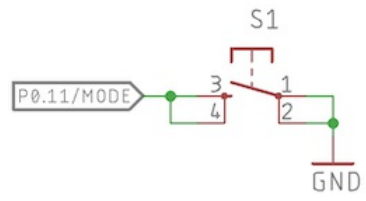
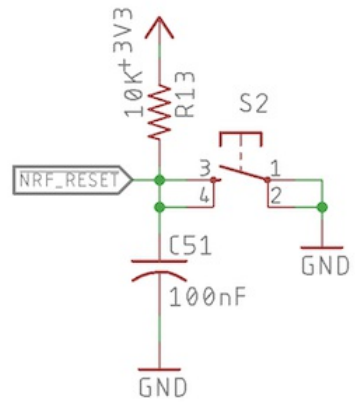
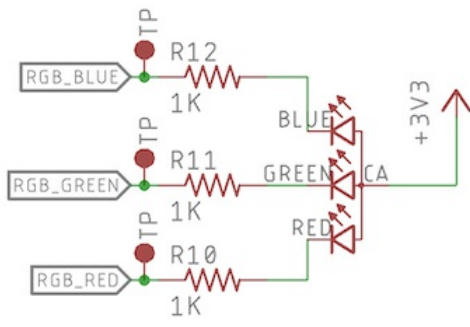

## Country compatibility

<b>Country</b>	<b>Model</b>	<b>Technologies</b>	<b>Carriers</b>
Canada	BRN404X	M1	Bell Mobility, Rogers Wireless, Telus
Mexico	BRN404X	M1	AT&T
United States	BRN404X	M1	AT&T

# Ordering information

Borons are available from [store.particle.io](https://store.particle.io).

SKU	Description	Region	Modem	EtherSIM	Lifecycle	Replacement
BRN404X	Boron LTE CAT-M1 (NorAm), [x1]	NORAM	R510	✓	In development	
BRN404XKIT	Boron LTE CAT-M1 (NorAm) Starter Kit, [x1]	NORAM	R510	✓	In development	
BRN404XTRAY50	Boron LTE CAT-M1 (NorAm), Tray [x50]	NORAM	R510	✓	In development	



## Qualification and approvals



\*\*BORON LTE (Cat M1) \*\*

- Model Number: BRN404X
- RoHS
- CE
- PTCRB
- FCC ID: 2AEMI-BRN404X
- IC: 20127-BRN404X

# Product Handling

## ESD PRECAUTIONS

The Boron contains highly sensitive electronic circuitry and is an Electrostatic Sensitive Device (ESD). Handling Boron without proper ESD protection may destroy or damage it permanently. Proper ESD handling and packaging procedures must be applied throughout the processing, handling and operation of any application that incorporates Boron. ESD precautions should be implemented on the application board where the Boron is mounted. Failure to observe these precautions can result in severe damage to the Boron!

## CONNECTORS

There are four connectors on the Boron that will get damaged with improper usage. The JST connector on the circuit board, where you plug in the LiPo battery, is very durable but the connector on the battery itself is not. When unplugging the battery, take extra precaution to **NOT** pull the connector using the wires, but instead hold the plug at its base to avoid putting stress on the wires. This can be tricky with bare hands - nose pliers are your friend here.

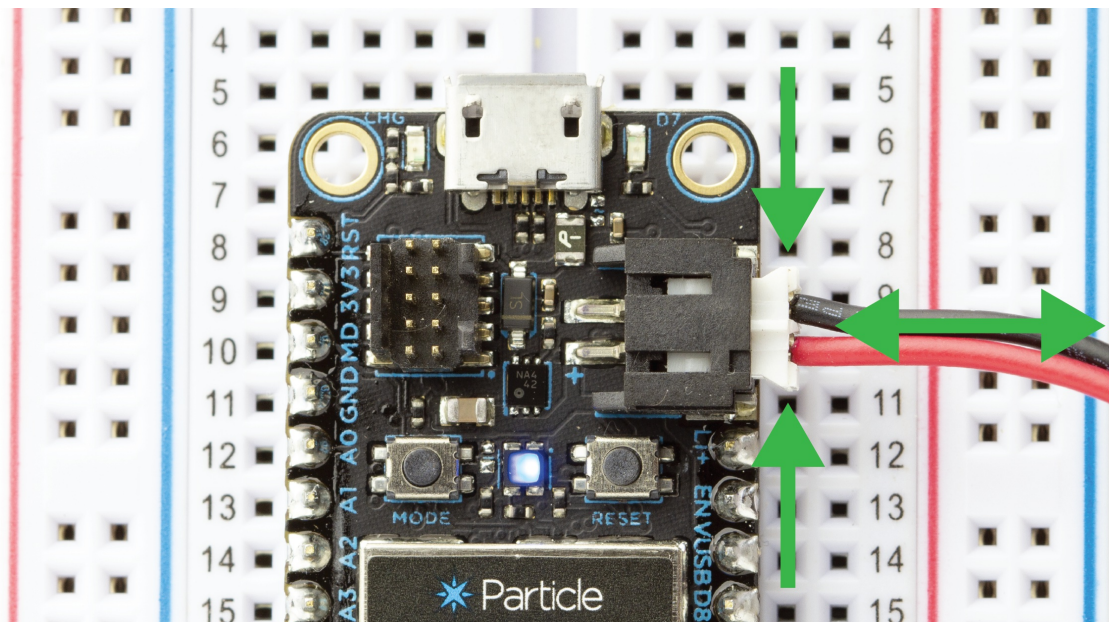

The micro B USB connector on the Boron is soldered on the PCB with large surface pads as well as couple of through hole anchor points. Despite this reinforcement, it is very easy to rip out the connector if too much stress is put on in the vertical direction.

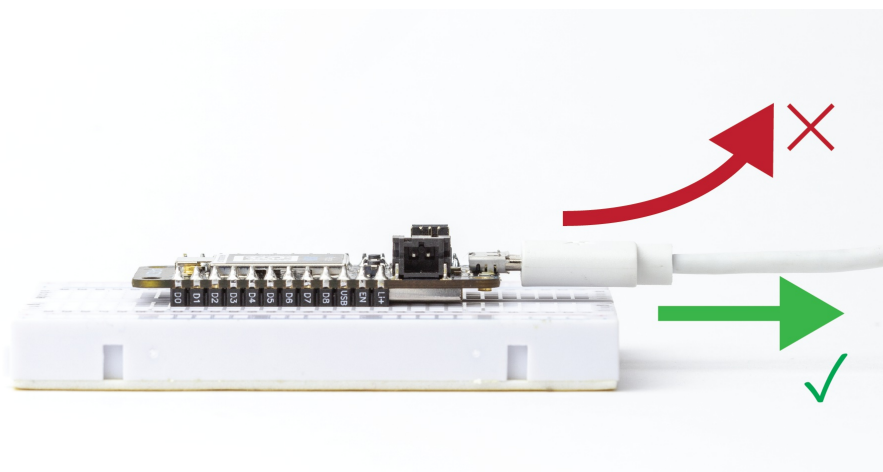

The U.FL antenna connector is not designed to be constantly plugged and unplugged. The antenna pin is static sensitive and you can destroy the radio with improper handling. A tiny dab of

glue (epoxy, rubber cement, liquid tape or hot glue) on the connector can be used securely hold the plug in place.

The 10 pin SWD connector provides an easy in-system debugging access to the device. The pins on the connector can easily be damaged if the mating connector cable is inserted improperly. If you are trying to debug the device, you probably are not in a good mood to begin with. The last thing you want is to render the connector useless. Be nice, and be gentle on the connector. Good luck with the debugging!

## **BREADBOARDING**

---

The breadboard provided with the Boron is specifically designed to require low insertion force. This makes it easy to plug the Boron in and out of the breadboard. If you end up using a different breadboard, remember that it may require more force. In this case, always remember to pinch-hold your precious Boron by the sides (along the header pins) when plugging-unplugging and not by the USB connector (don't be this person).

## Default settings

The Boron comes preprogrammed with a bootloader and a user application called Tinker. This application works with an iOS and Android app also named Tinker that allows you to very easily toggle digital pins, take analog and digital readings and drive variable PWM outputs.

The bootloader allows you to easily update the user application via several different methods, USB, OTA, Serial Y-Modem, and also internally via the Factory Reset procedure. All of these methods have multiple tools associated with them as well.

# FCC IC CE Warnings and End Product Labeling Requirements

**Federal Communication Commission Interference Statement** This equipment has been tested and found to comply with the limits for a Class B digital device, pursuant to Part 15 of the FCC Rules. These limits are designed to provide reasonable protection against harmful interference in a residential installation. This equipment generates, uses and can radiate radio frequency energy and, if not installed and used in accordance with the instructions, may cause harmful interference to radio communications. However, there is no guarantee that interference will not occur in a particular installation. If this equipment does cause harmful interference to radio or television reception, which can be determined by turning the equipment off and on, the user is encouraged to try to correct the interference by one of the following measures:

- Reorient or relocate the receiving antenna.
- Increase the separation between the equipment and receiver.
- Connect the equipment into an outlet on a circuit different from that to which the receiver is connected.
- Consult the dealer or an experienced radio/TV technician for help.

**FCC Caution:** Any changes or modifications not expressly approved by the party responsible for compliance could void the user's authority to operate this equipment. This device complies with Part 15 of the FCC Rules. Operation is subject to the following two conditions:

1. This device may not cause harmful interference, and
2. This device must accept any interference received, including interference that may cause undesired operation.

**FCC Radiation Exposure Statement:** This equipment complies with FCC radiation exposure limits set forth for an uncontrolled environment. This transmitter module must not be co-located or operating in conjunction with any other antenna or transmitter. This End equipment should be installed and operated with a minimum distance of 20 centimeters between the radiator and your body.

**IMPORTANT NOTE:** In the event that these conditions can not be met (for example certain laptop configurations or co-location with another transmitter), then the FCC authorization is no longer considered valid and the FCC ID can not be used on the final product. In these circumstances, the OEM integrator will be responsible for re-evaluating the end product (including the transmitter) and obtaining a separate FCC authorization.

**End Product Labeling** The final end product must be labeled in a visible area with the following:

- Contains FCC ID: 2AEMI-BRN404X

**Manual Information to the End User** The OEM integrator has to be aware not to provide information to the end user regarding how to install or remove this RF module in the user's manual of the end product which integrates this module.

**Canada Statement** This device complies with Industry Canada's licence-exempt RSSs. Operation is subject to the following two conditions:

1. This device may not cause interference; and
2. This device must accept any interference, including interference that may cause undesired operation of the device.

Le présent appareil est conforme aux CNR d'Industrie Canada applicables aux appareils radio exempts de licence.

**L'exploitation est autorisée aux deux conditions suivantes:**

1. l'appareil ne doit pas produire de brouillage;
2. l'utilisateur de l'appareil doit accepter tout brouillage radioélectrique subi, même si le brouillage est susceptible d'en compromettre le fonctionnement.

**Caution Exposure:** This device meets the exemption from the routine evaluation limits in section 2.5 of RSS102 and users can obtain Canadian information on RF exposure and compliance. Le dispositif répond à l'exemption des limites d'évaluation de routine dans la section 2.5 de RSS102 et les utilisateurs peuvent obtenir des renseignements canadiens sur l'exposition aux RF et le respect.

**The final end product must be labelled in a visible area with the following:** The Industry Canada certification label of a module shall be clearly visible at all times when installed in the host device, otherwise the host device must be labelled to display the Industry Canada certification number of the module, preceded by the words "Contains transmitter module", or the word "Contains", or similar wording expressing the same meaning, as follows:

- Contains transmitter module IC: 20127-BRN404X

This End equipment should be installed and operated with a minimum distance of 20 centimeters between the radiator and your body. Cet équipement devrait être installé et actionné avec une distance minimum de 20 centimètres entre le radiateur et votre corps.

The end user manual shall include all required regulatory information/warning as shown in this manual.

## Revision history

<b>Revision</b>	<b>Date</b>	<b>Author</b>	<b>Comments</b>
010	2022-09-06	RK	Split out from rest of the Boron line
011	2022-09-07	RK	Add additional port and pin information
012	2022-09-16	RK	Add minimum Device OS version, is 4.0.0

## Known Errata