

# Demoboard BTS3xxxEJ

## About this document

### Scope and purpose

This document gives a fast introduction to the BTS3xxxEJ demoboard.

### Intended audience

Engineers, hobbyists and students who want to add powerful Low Side Switches to their projects.

## Related information

**Table 1** Supplementary links and document references

Reference	Description
<a href="#">HITFET Home Page</a>	Product page which contains reference information for the HITFET+ family
<a href="#">Arduino Home Page</a>	All information on Arduino
<a href="#">Arduino Uno Product Page</a>	Arduino Uno R3 description
<a href="#">DAVE™ Development Platform</a>	All details on DAVE™ IDE
<a href="#">XMC1100 Boot Kit</a>	Product page which contains reference information for the XMC1100 Boot Kit

## 1 Demoboard BTS3xxxEJ

*Note: The following information is given as a hint for the implementation of the device only and shall not be regarded as a description or warranty of a certain functionality, condition or quality of the device*

### Basic Features of this Demoboard

- RoHS compliant
- Driving one 12V resistive, capacitive or inductive load
- Arduino/XMC1100 Boot Kit compatible
- Diagnosis function
- Programmable push button integrated
- Additional equipment needed: 1x 12V power supply; 1x 5V signal generator and 5V power supply, or Arduino Uno/XMC1100 Boot Kit

### Description of how to use the Demoboard

This description is intended to give a fast introduction to the BTS3xxxEJ demoboard. The demoboard gives the user a quick start for lab evaluation of the BTS3xxxEJ. Stand-alone operation is possible.

The BTS3xxxEJ demoboard (PCB size: 53 x 58 mm<sup>2</sup>) has 2 layers (70µm copper). It is equipped with one sample of BTS3035EJ, BTS3050EJ, BTS3080EJ, or BTS3125EJ. **Figure 1** gives an overview of the demoboard. **Table 2** provides a description of major parts of the demoboard. The schematic and an example for external connection are given in **Figure 2** and **Figure 3**.

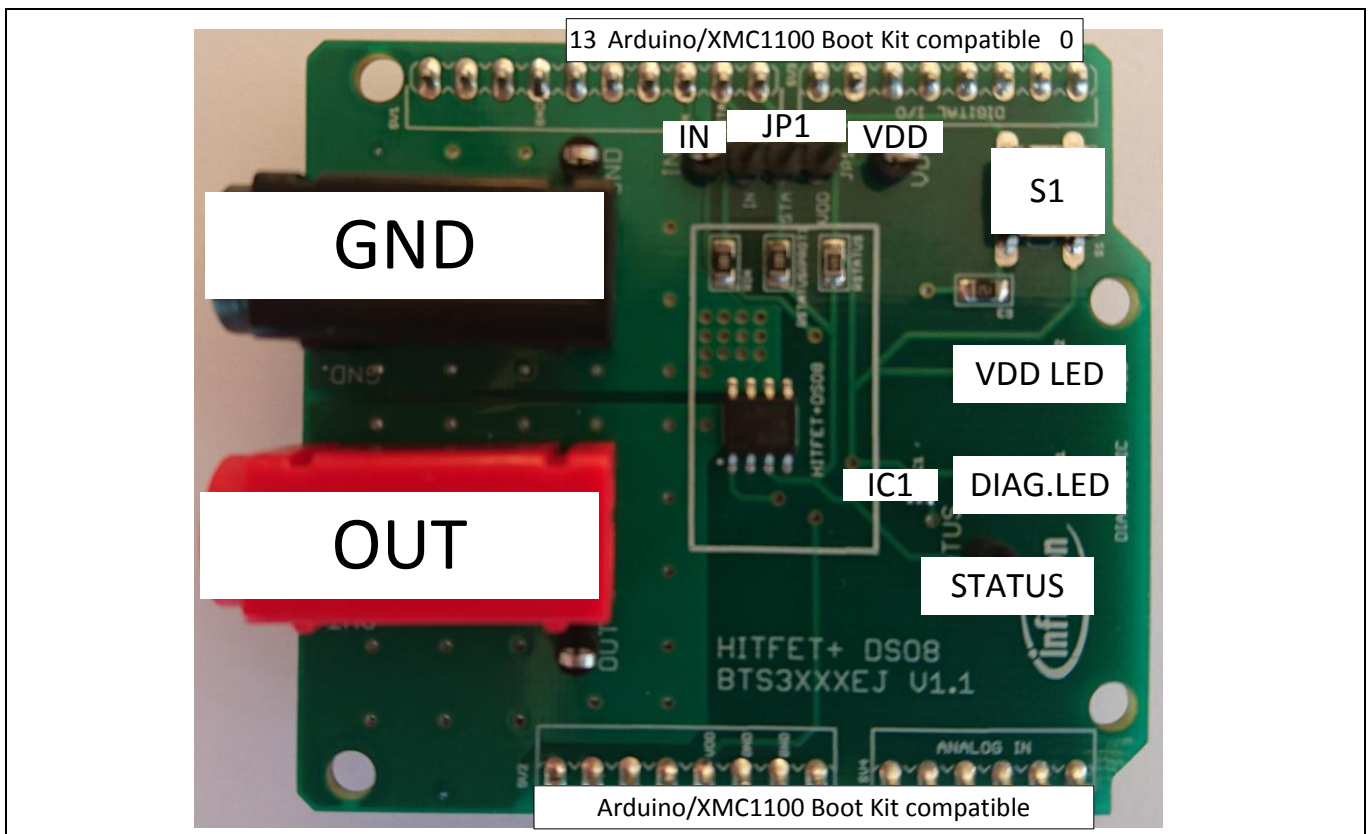

**Figure 1 Board Overview**

**Table 2 Part Description**

Name	Description
IN	Input signal; TTL logic level (5V recommended), can be supplied with Arduino/XMC1100 Boot Kit
OUT	Output/Load; refers to the OUT pin of the device. Load to battery supply line. For inductive loads check energy capabilities on device datasheet
GND	Ground; connect all grounds to this pin
STA	Output signal for diagnostic function; if $V_{STA} = 0V$ , fault feedback is present. Fault feedback resets if $V_{IN}=0V$ . For use with microcontroller (include $R_{STATUS(Prot)}$ )
STATUS	Output signal for diagnostic function; if $V_{STA} = 0V$ , fault feedback is present. Fault feedback resets if $V_{IN}=0V$ . To be used as test point
VDD	Supply voltage; connect with 5V, if no Arduino/XMC1100 Boot Kit is used
DIAGNOSTIC LED	FAULT indicator; If LED (red) is on, the fault feedback is active
VDD LED	VDD supply indicator; If LED (green) is on, VDD supply is connected
S1	Push button with pull down resistor for customizable use; programmable via Arduino/XMC1100 Boot Kit
JP1	To be used as extra testing points for IN, STA and VDD. Short STA with IN or VDD is not needed
IC1	Inverter; Inverts signal of $V_{STATUS}$ in order to turn DIAGNOSTIC LED on/off (74LVC1G14GW-Q100)

**Table 3 Arduino Uno/XMC1100 Boot Kit Pin Out**

Arduino Uno	XMC1100 Boot Kit	Description
8	P0.12	S1
9	P0.8	STA
10	P0.9	IN
GND	GND	GND
5V	5V	VDD

Demoboard BTS3xxxEJ

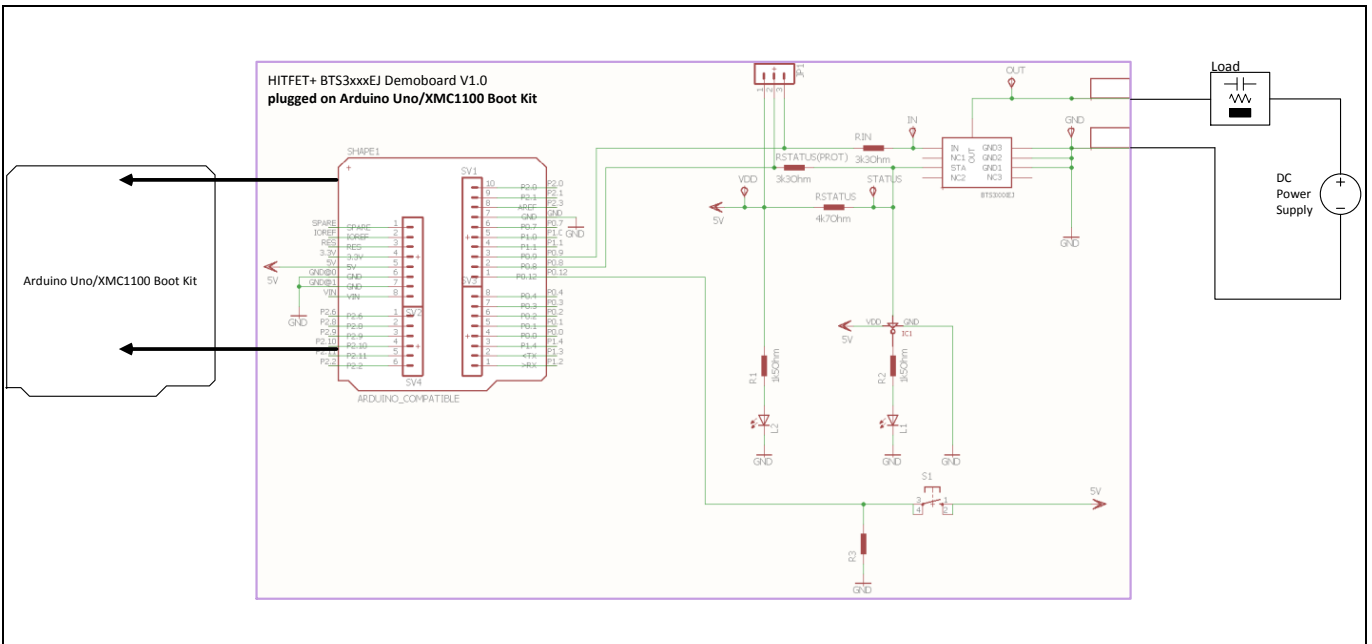

Figure 2 Demoboard Setup with Arduino Uno / XMC1100 Boot Kit

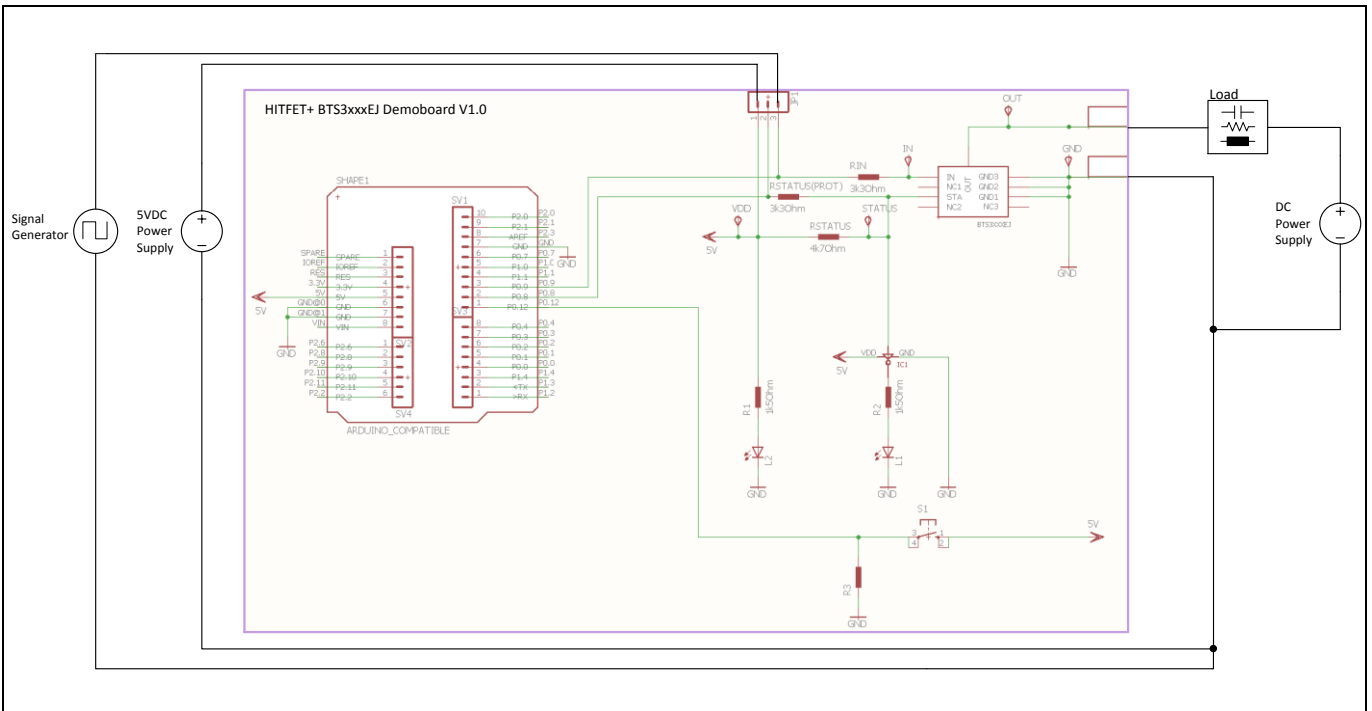

Figure 3 Demoboard Setup stand-alone

Note: Figure 2 and Figure 3 show the demoboard schematics and a very simplified application example. The function in real applications must be verified to not exceed the limits of the device nor the demoboard and its components.



## Revision History

### Major changes since the last revision

Page or Reference	Description of change
V1.0	Release of Demoboard Description