

2-Wheeler starter relay with Power PROFET™

BTS50010-1TAE

About this document

Scope and purpose

This application note presents the Infineon power PROFET™ BTS50010-1TAE used as **Solid State Relay (SSR)** to drive the starter motor of a scooter or a motorcycle (engine smaller than 150 cc).

A typical application diagram is presented and measurement results are discussed. Critical failure conditions (reverse battery connection, loss of supply) are described and solutions are proposed to protect BTS50010-1TAE.

Finally, the integration with the vehicle **Engine Control Unit (ECU)** is discussed and the demoboard is described.

Intended audience

OEMs manufacturing scooters and motorcycles with an engine smaller than 150 cc, their Tiers 1 and Tiers 2 providing equipment for such 2-wheelers, looking for electromechanical relay replacement by a silicon solution.

Table of contents

	About this document	1
1	Introduction to Scooter Starter Relay	2
2	Using Infineon PROFET™ BTS50010-1TAE as SSR for scooters and motorcycles	4
3	Driving a small ICE starter motor (< 150 cc)	6
3.1	Application diagram	6
3.2	Switching waveforms	7
3.3	Loop inductance estimation via data curve fitting	10
3.4	Switching-OFF behaviour	11
3.5	Current sensing	19
3.6	Undervoltage protection	21
3.7	Battery disconnection	22
3.8	Reverse battery protection	24
4	Practical considerations	26
4.1	ECU integration (space estimation)	26
4.2	Demoboard	28
5	Reference list	30
6	Revision history	31
	Disclaimer	32

1 Introduction to Scooter Starter Relay

1 Introduction to Scooter Starter Relay

In general, an Internal Combustion Engine (ICE) starter motor is a machine used to provide the initial torque (crank) for the main combustion engine for few mechanical cycles. It is also known as a cranking motor or simply as a starter.

For motorcycles or scooters with engines smaller than 150 cc, the most known solution is a small DC brushed motor. Such motors are attractive due to their relatively small size, torque ratio, simplicity and cost effectiveness.

The challenge comes from the low voltage generated by the on board battery: 12 V. Indeed, the torque required to activate the combustion engine during the first few cranks is very high, which means that the electrical power required is also very high. This translate into a very high current since the battery voltage is rather low. For engines below 150 cc, the inrush current to be delivered to the starter can go up to 250 A.

The logic circuit connected to the relay control coil defines the operation of the mechanical contact of the relay. There are very often three switches:

- Engine stop switch (normally on): this mechanical switch is usually unlocked by the user through a mechanical key. The key needs to be inserted and activated to power-up the motor cycle. It is then possible to start the Internal Combustion Engine
- Ignition switch (normally off): this is a push button, in general, which is activated by the user to start the engine. This button will not operate if the motor cycle is not yet powered up thanks to the main key
- Kickstand stop switch: there is at least one security on the ignition circuit: if the lateral kickstand is unlocked, it is necessary to prevent the Internal Combustion Engine to start for safety reasons. A dedicated switch is used to sense if the kickstand is locked or not

Besides these switches, a fuse protects the power path from the battery to the starter Motor.

The system described above is illustrated in [Figure 1](#).

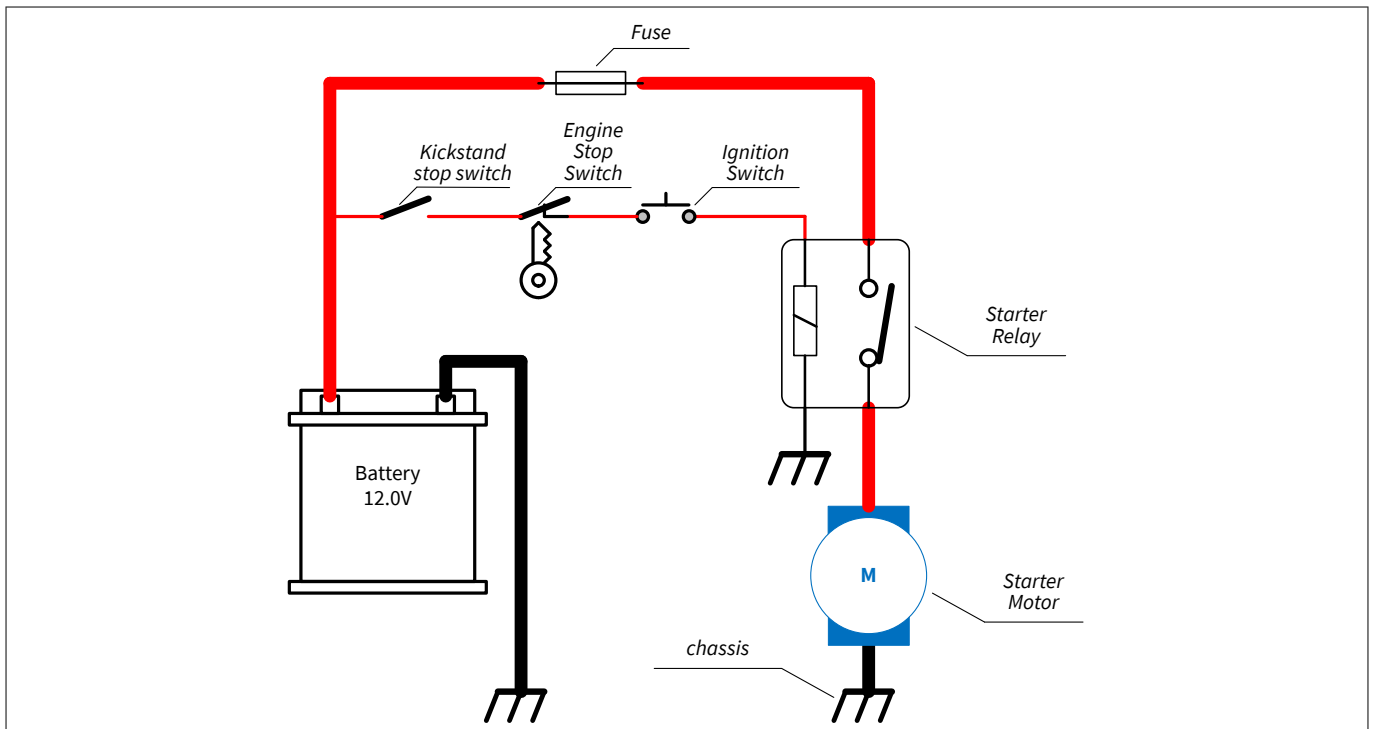

Figure 1 Starter relay basic circuit schematics

The system described in the [Figure 1](#) is straightforward and elementary; there are many variants in the market and the target here is not to describe all of them. The intention is to highlight the most common building blocks and to discuss some of the drawbacks inherent to its electromagnetic structure.

1 Introduction to Scooter Starter Relay

Due to the high inrush current at start-up and the high energy at switch-off coming from the demagnetization of the motor inductance, the electromechanical relays survive in the range of 50 000 ON-OFF cycles. In countries where the people are asked to switch off their engine anytime their motorcycle is stopped (traffic jams, lights etc.), such a low number of cycles provides approximately 3.5 years lifetime. A lot of users do therefore have to replace their relay over the lifetime of their motorcycle.

For some intensive users, this time could even be reduced such that it falls inside the warranty time specified by the **O**riginal **E**quipment **M**anufacturer (OEM). The OEM has then to cover the replacement expenses.

Using a solid state relay such as the BTS50010-1TAE is an easy and cost effective way to extend the life time of the starter relay, since the number of ON-OFF cycles can go beyond 1 million cycles.

It is also consistent with the current trends in motor control, where electronically-controlled fuel injection becomes a must due to the strong regulations on CO2 emissions everywhere on the globe. Since an Electronic Control Unit (ECU) for motor control has to be integrated on any motorcycle, it becomes easier to use an electronic component to replace the starter relay since it can be located on that ECU.

2 Using Infineon PROFET™ BTS50010-1TAE as SSR for scooters and motorcycles

2 Using Infineon PROFET™ BTS50010-1TAE as SSR for scooters and motorcycles

Power PROFET™ (**PRO**TECTED MOSFET) is a family of benchmark high side switches, dedicated to relay and fuse replacement for high current applications. Specifically, BTS50010-1TAE is a 1 mΩ single channel smart high-side power switch, embedded in a D²PAK 7-pin package, providing protective functions and diagnosis. The power transistor is built by an N-channel power MOSFET with charge pump.

The provided protections and diagnosis functionalities include:

- Undervoltage shutdown (threshold is 5 V ± 0.5 V)
- Reverse battery protection by turning on the internal MOSFET
- Secure load turn-off during loss of ground (GND)
- Overtemperature and overcurrent (short circuit) protection with latch-off mechanism

A block diagram illustrating the overall functionalities of the BRS50010-1TAE [1] is shown in [Figure 2](#).

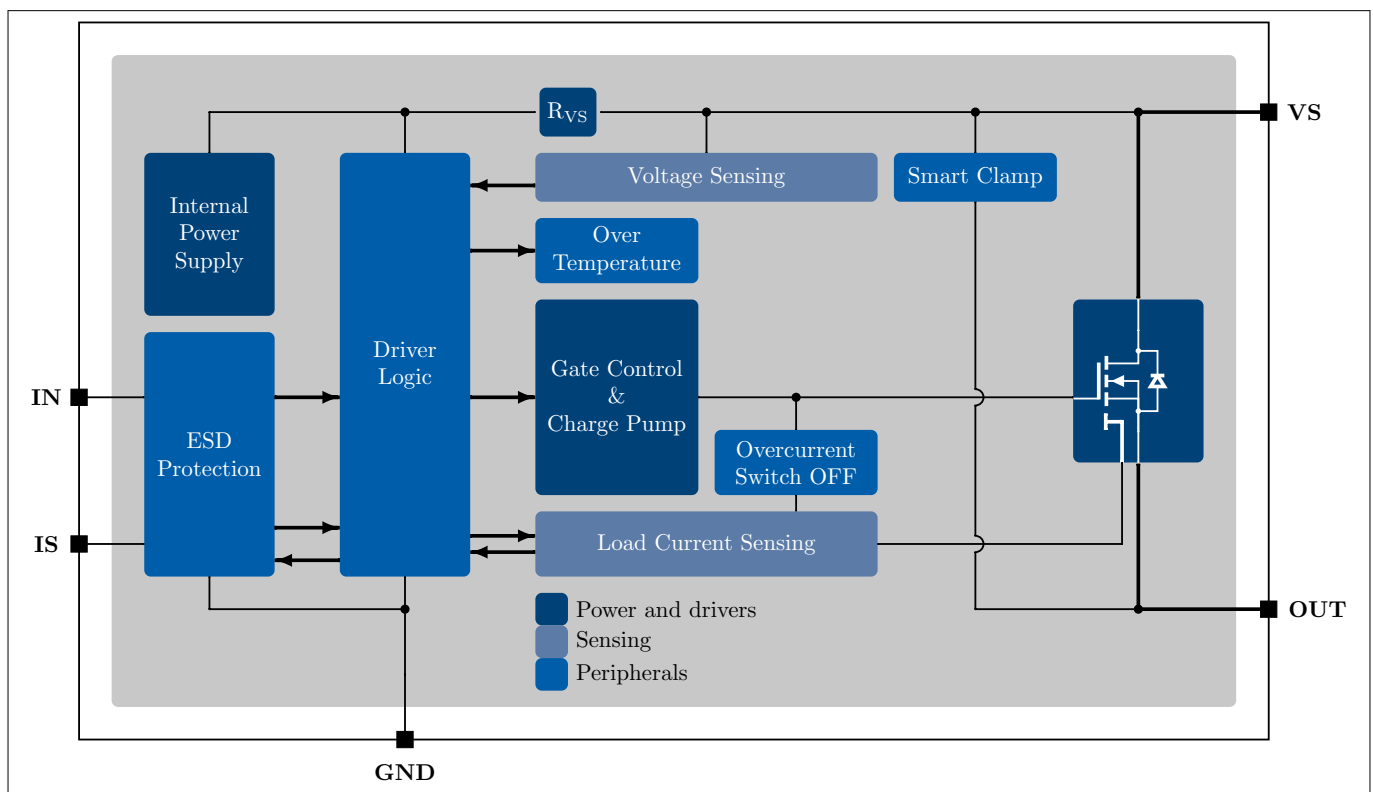

Figure 2 Block Diagram for the BTS50010-1TAE

The use of the BTS50010-1TAE brings reduced volume and weight (below 1.5 g): it is unbeatable in comparison to the bulky starter relays (4 g to 40 g).

In the harsh motorcycle environment, electrical failures may happen intermittently due to mechanical stress, unstable wire connections, customer errors and also aging. With electromechanical solutions based on relay and fuse, in the event of a short-circuit, the fuse has to be replaced. With BTS50010-1TAE, the system is protected against short-circuits without the need to replace any part: once the short is removed, the protections can be reset. This is managed electrically, through the Input control signal of BTS50010-1TAE.

2 Using Infineon PROFET™ BTS50010-1TAE as SSR for scooters and motorcycles

Table 1 Comparison features between the relay and fuse system and PROFET™ SSR solution

	Relay	BTS50010-1TAE SSR
Immunity to aging	Low	Higher
Immunity to corrosion	No	Yes
High number of cycles capability	No	Yes
Microcontroller direct drivability	No	Yes
Self-Protection	Once	Resettable
Diagnosis	No	Yes
Efficiency	Low	High

3 Driving a small ICE starter motor (< 150 cc)

3 Driving a small ICE starter motor (< 150 cc)

3.1 Application diagram

Figure 3 shows a possible implementation of an SSR for starter motor used on motorcycles with a small engine (< 150 cc). This diagram presents two options for the SSR control:

1. No microcontroller is present, the ignition order is given through a mechanical switch connected to R_{IN_PU} and R_{IN_PD} resistor divider
2. A microcontroller is present, typically the one on the ICE control ECU, which interfaces with BTS50010-1TAE to trigger the engine cranking (through pin IN) and monitors the load current and protection status (through pin IS). A few passive components are used between the microcontroller and BTS50010-1TAE, either for filtering reasons (C_{IS_Filt}), for protection in case of reverse battery polarity (R_{IS_prot} and R_{IN}) or to convert the sense current into a voltage which can be sampled by an Analog to Digital (A/D) converter in the microcontroller (R_{IS})

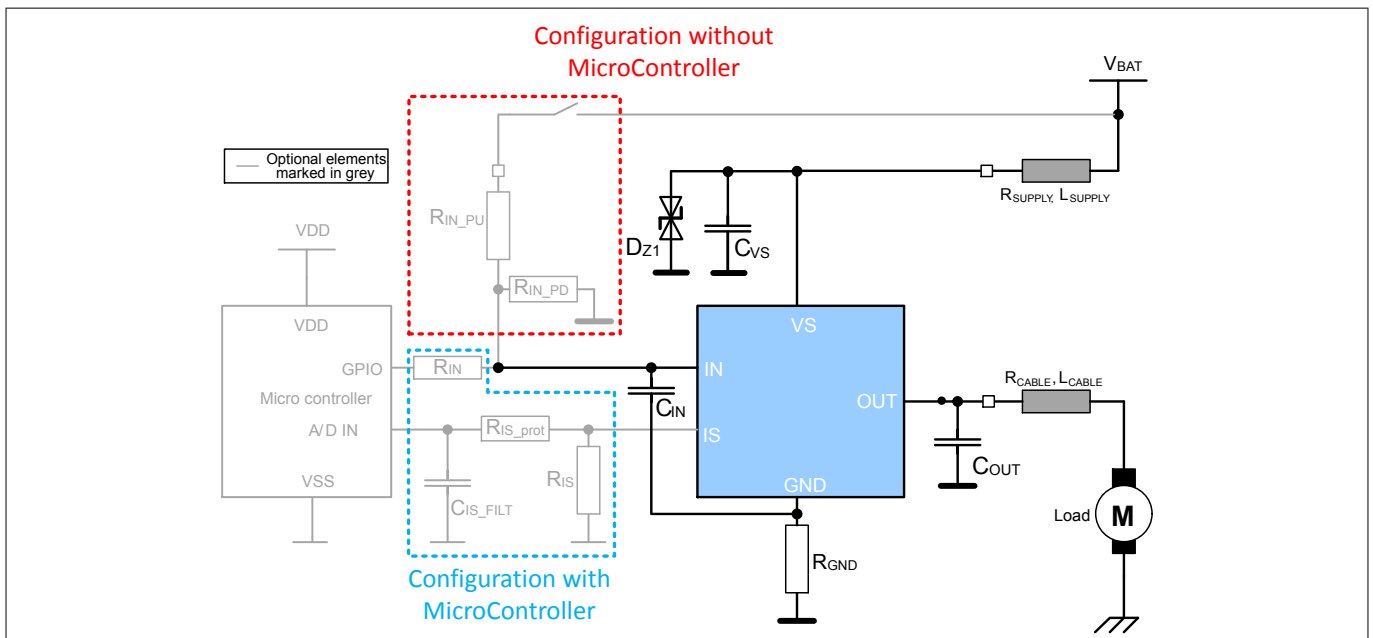

Figure 3 Application diagram with the BTS50010-1TAE

Whatever the control option (with or without microcontroller), there are a few mandatory passive components:

- Supply filtering: C_{VS}
- Protection against loss of Supply and Loss of Load: $DZ1$ (see section 5.3.2 in BTS50010-1TAE datasheet [1])
- Input Filtering: C_{IN}
- EMC and ESD protection: C_{OUT}
- Reverse battery protection: R_{GND}

3 Driving a small ICE starter motor (< 150 cc)

Table 2 **Component values**

Reference	Value	Purpose
R_{GND}	10 Ω	Protection in case of overvoltage and loss of battery while driving inductive loads
D_{Z1}	$V_{\text{BR}} = 40 \text{ V}$	Suppressor (TVS) diode. Protection during overvoltage and in case of loss of battery while driving inductive loads. More details in Chapter 3.7
C_{VS}	100 nF	Improved EMC behaviour (in layout, please place close to the pins)
C_{OUT}	10 nF	Improved EMC behaviour (in layout, please place close to the pins)
C_{IN}	150 nF	Together with R_{IN} , C_{IN} ensures that the voltage applied on $/\text{N}$ pin is delayed compared to a rising edge on the supply ($/\text{S}$ pin)
$R_{\text{IN_PD}}$	4.7 k Ω	Fast discharge of C_{IN}
R_{IN}	4.7 k Ω	Protection of the microcontroller during transient pulses and reverse polarity
R_{IS}	1 k Ω	Sense resistor; if IS signal is not used, leave $/\text{S}$ pin open
$R_{\text{IS_PROT}}$	4.7 k Ω	Protection of the microcontroller during overvoltage Protection of the BTS50010-1TAE during reverse polarity
$C_{\text{IS_FLT}}$	10 nF	Sense signal filtering

In the next chapters, several measurements will be discussed in a real case where BTS50010-1TAE is used as a motor starter silicon-based relay. For all these tests, the motor used to emulate a motor starter silicon-based relay is a 12 V 0.35 kW DC-brushed machine.

The schematic is derived from the one illustrated on [Figure 3](#).

3.2 Switching waveforms

The target of the test shown here is to illustrate waveforms during regular switch ON and OFF on the motor starter load.

During these switching tests, the rotor of the electrical machine is **kept locked**, simulating a blocked motor. Indeed, this is the worst condition in terms of current (stall current can be as high as 250 A) and as a result, generates a severe inductive demagnetization pulse when the BTS50010-1TAE is driven to switch OFF. This current is limited by four main parameters:

- the battery voltage
- the battery output resistance
- the wiring resistance
- the motor series resistance

To have the flexibility to control this current, the test set up has been defined based on a battery emulator rather than a real 12 V motorcycle battery. This emulator is built with a powerful power supply followed by a resistor bank. It allows to easily configure the supply voltage and the emulated battery output resistance and the wiring resistance.

3 Driving a small ICE starter motor (< 150 cc)

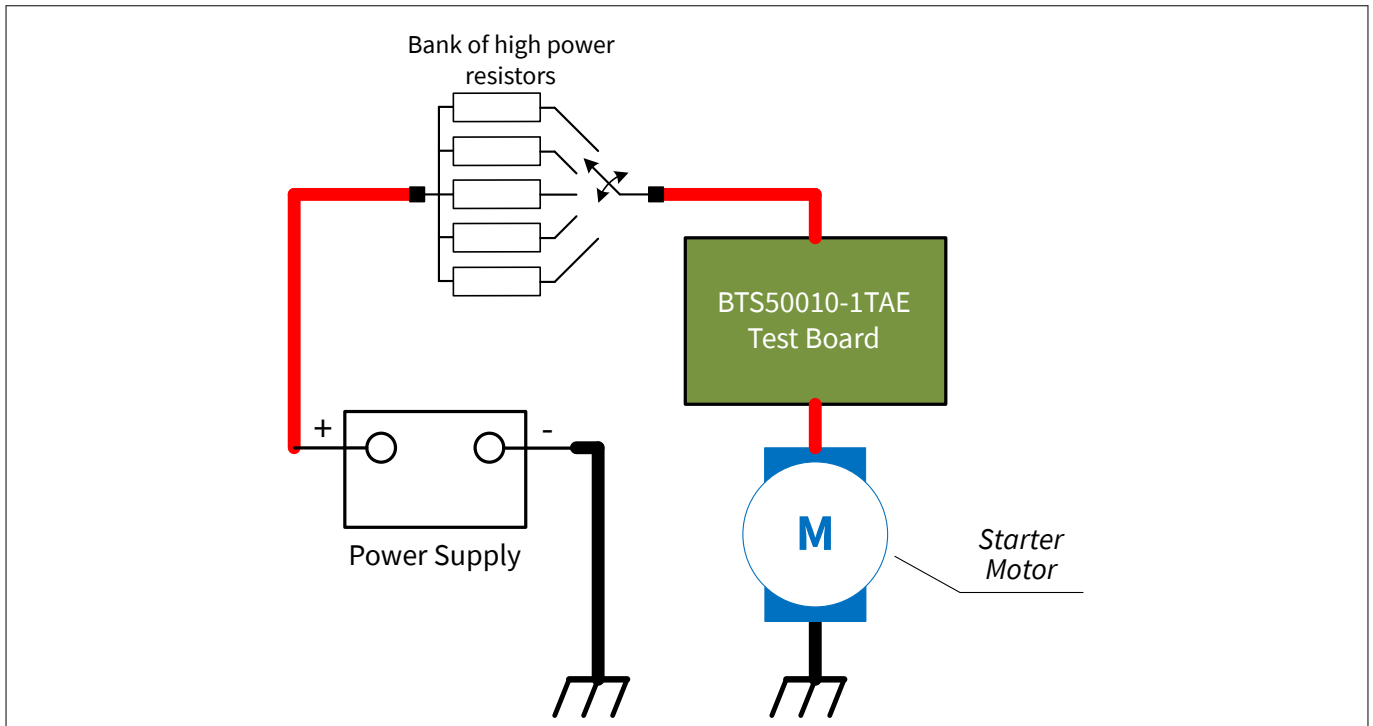

Figure 4 Battery emulator, built with a power supply followed by a resistor bank

BTS50010-1TAE is activated via the IN signal (active High), as it is illustrated in the [Figure 5](#).

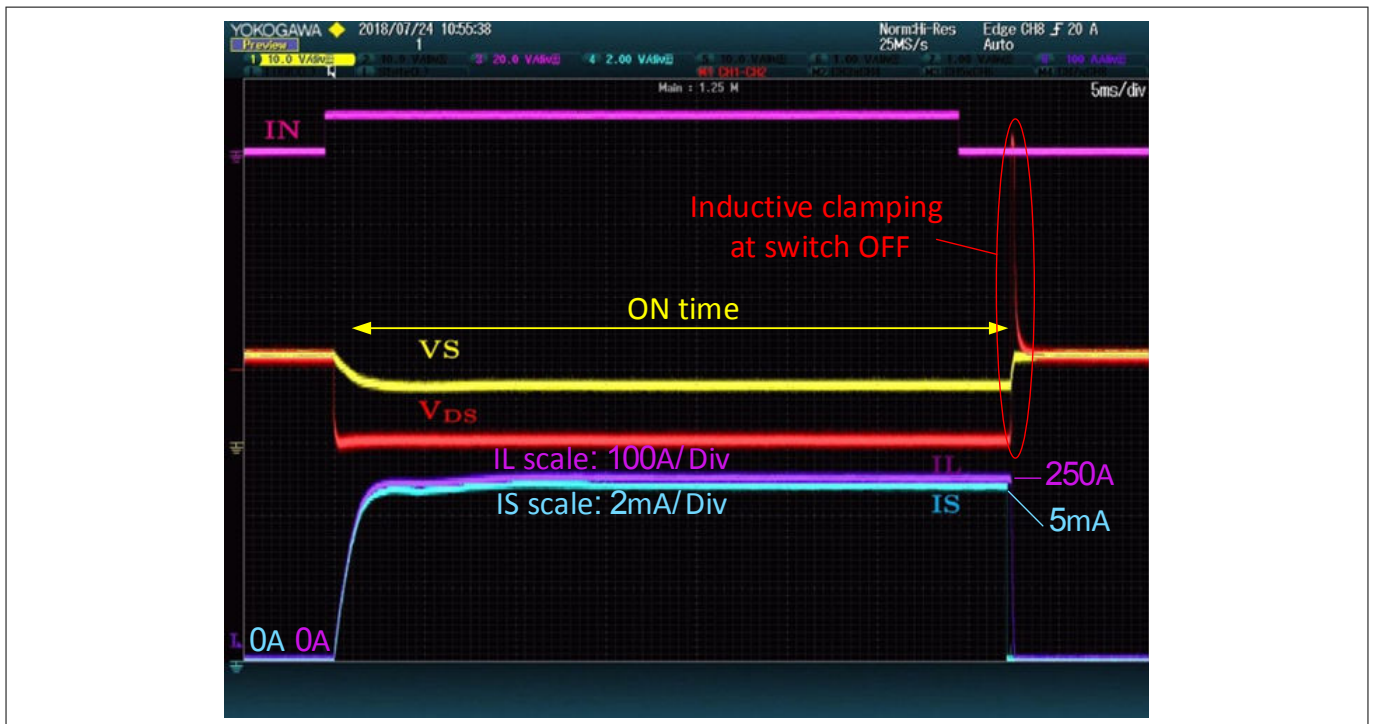

Figure 5 Switching behavior of the BTS50010-1TAE

The pulse duration applied on the *IN* pin of the BTS50010-1TAE is approximately 35 ms long. Such short pulse width was selected in order to only verify the waveforms behavior during the current rise and falling edges. In the next chapters, more realistic values for the pulse duration will be considered to check the behavior during a motor stall condition (from 1 s to 2 s for load current equals to 250 A).

3 Driving a small ICE starter motor (< 150 cc)

During the time the device is enabled, the load current I_L rises to the motor in-rush current value since the rotor is mechanically blocked: roughly 250 A. Since the device is enabled, the drain-to-source voltage is defined by $R_{DS(ON)} \cdot I_L$ and there is a noticeable voltage drop on the input pin V_S due the emulated battery resistance plus the cable resistances (V_S drops to approximately 8 V).

Figure 6 shows a zoom on the switch ON phase:

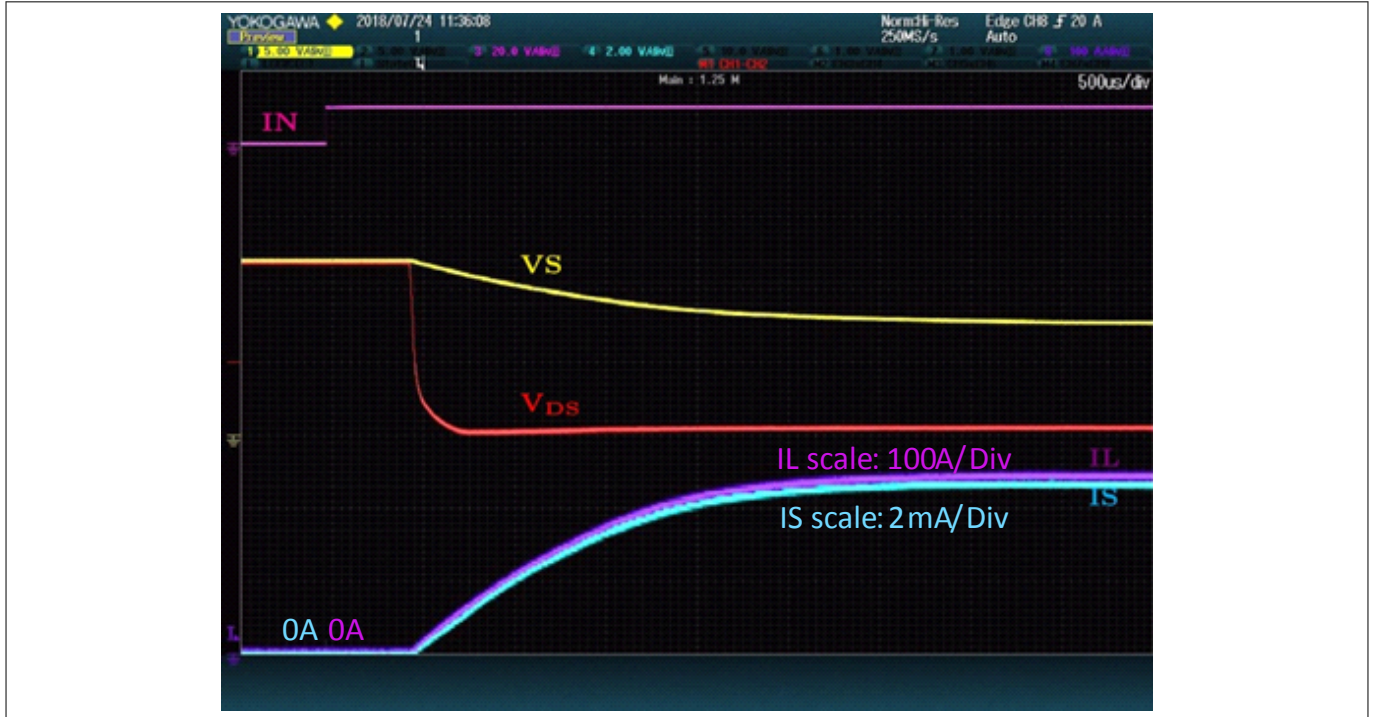

Figure 6 Switch ON event

At switch off, due to the motor inductance and the cables parasitic inductance, the device is driven to avalanche, and the voltage is clamped at a value slightly larger than 40 V. During this phase, the device is dissipating the very high energy accumulated in the inductances in the system. This is discussed further in [Chapter 3.4](#).

For the time being, we have first to estimate the motor inductance.

3 Driving a small ICE starter motor (< 150 cc)

3.3 Loop inductance estimation via data curve fitting

Different method can be used to estimate the loop inductance parameters.

The one selected here requires a curve fitting algorithm for the acquired oscilloscope data. At first, it is considered that, in the current loop, one can approximate the behavior of the load current as a simple first order RL circuit. Then, the equation considered for the curve fitting iterations is the exponential function given by the equation:

$$I_L(t) = I_o \left(1 - e^{-\frac{t}{\tau}} \right)$$

Equation 1

Where I_L is the load current, I_o is the steady state value for the load current and τ is the load time constant. For an inductor, the time constant is defined as: $\tau = \frac{L}{R_S}$ where L is the motor inductance and R_S is the motor series resistance.

The time t considered in **Equation 1** is specified to be 0 at the origin.

In order to guarantee that the fitting curve algorithm converges, only the rising edge of the acquired current is used as input data. The easiest way is to limit the acquisition performed by the oscilloscope to the rising edge, with the beginning of the edge positioned at the left origin of the display.

For the present study the current waveform and the curve fitting results are compared and they are illustrated in the chart in the **Figure 7**. The measured load current is the black trace and the associated fitted curve is given by the red trace.

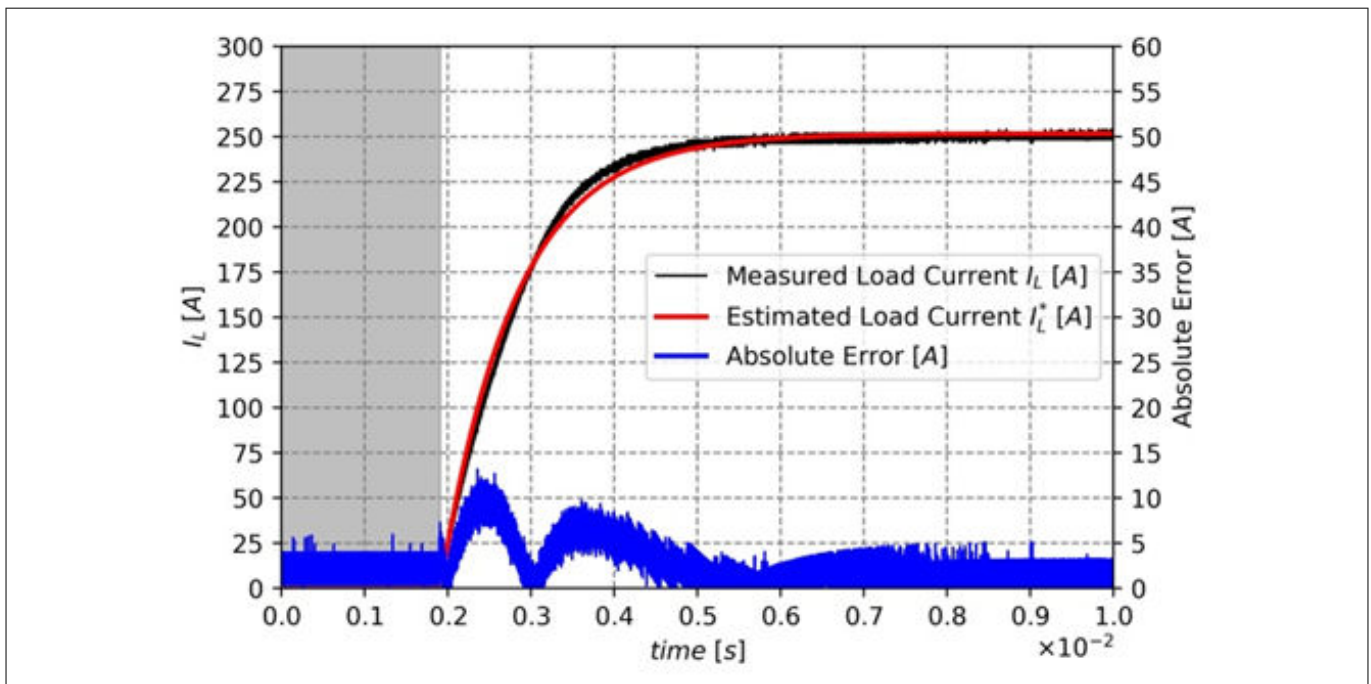

Figure 7 Curve fitting results for the loop inductance estimation

The hashed grey area in the chart illustrates the points excluded from the fitting process.

Once computed, the fitting process leads to the following values (with a reasonable error, as displayed in blue on **Figure 7**):

- The steady state current value is: $I_o = 252$ A (value for $t > 0.6$ s)
- The steady state output voltage is: $V_{OUT} = 7.4$ V (value for $t > 0.6$ s)
- The time constant is: $\tau = 890$ μ s

The calculated total resistance (including the cables and the motor series resistance) is:

3 Driving a small ICE starter motor (< 150 cc)

$$R_{TOT} = V_{OUT} / I_0 = 7.4 / 252 = 29 \text{ m}\Omega.$$

From the time constant τ and the total resistance, the loop inductance is:

$$L_{TOT} = R_{TOT} \times \tau = 890.10 \times 10^{-6} \times 29.10 \times 10^{-3} = 26 \text{ }\mu\text{H}.$$

3.4 Switching-OFF behaviour

As it is described in section 5.1.3 of BTS50010-1TAE datasheet [1], when switching off on an inductive load, there is a demagnetization phase during which the PROFET™ is in smart clamping. Indeed, in order for the current in the inductance to decrease, the voltage polarity on the motor terminal has to be reversed and BTS50010-1TAE applies a negative voltage $V_{DEMAG} = - [V_{DS}(CL) - V_S]$ (around - 25 V at the end of a regular start up).

The associated power represents several kiloWatts, fortunately limited to a fraction of a millisecond.

The high power injected in the MOSFET generates a significant temperature increase. It is therefore necessary to check if this stress may damage the BTS50010-1TAE or not.

The way to proceed here is as follows:

1. First, define the worst case condition in terms of current at switch OFF
2. Check if the condition may apply many times over the lifetime of the device or only a very limited number of times
 - a. If it applies many times, use the EAR curve as plotted in figure 5, section 4.1 of the BTS50010-1TAE datasheet [1]
 - b. If it applies a handful of times, then use the EAS curve from the same figure 5
3. Calculate the energy dissipated inside the device using the formula 5.1 defined in section 5.1.3.2 of the BTS50010-1TAE datasheet [1]
4. Check if this energy level is compatible with either the EAR or the EAS curve, as appropriate

The worst case condition to consider is when the PROFET™ switches OFF while the starter motor is in stall condition as illustrated on **Figure 8** :

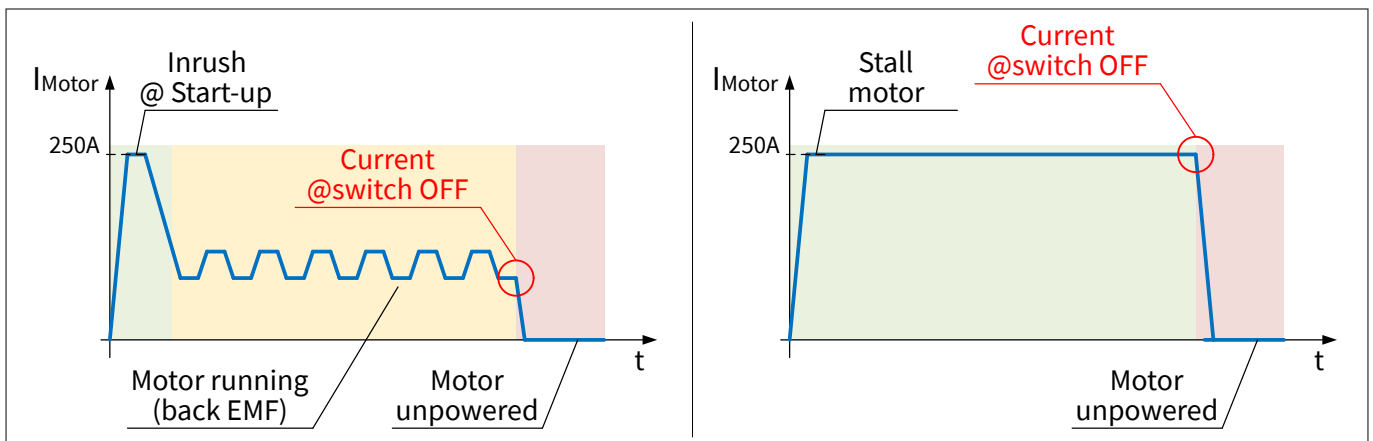

Figure 8 Starter motor current profile in regular start-up (left) and in stall condition (right)

Our assumption here is that the current in blocked mode can be 250 A. This is a failure mode, which should take place a very limited number of time over the lifetime of the motorcycle: the EAS curve can be used here.

The switch OFF will very likely be generated by the overtemperature protection. Indeed, the power dissipation inside BTS50010-1TAE to deliver 250 A is very high, which leads to a significant increase of the MOSFET temperature. The thermal simulation on **Figure 9** shows that the MOSFET temperature is above 150°C after less than 0.8 s at 250 A load current, starting from an ambient temperature of 25°C. So if the control signal on the *IN* pin is high for more than 0.8 s, the component will switch OFF due to the over temperature protection. It is highly recommended to monitor the *IS* pin signal once the device is turned ON: as described in **Chapter 3.5**, this signal allows to know the load current and it is therefore possible to decide to switch OFF BTS50010-1TAE if the

3 Driving a small ICE starter motor (< 150 cc)

current if high for a longer time than a standard inrush. In such a way, the temperature increase in BTS50010-1TAE is reduced and its lifetime is extended.

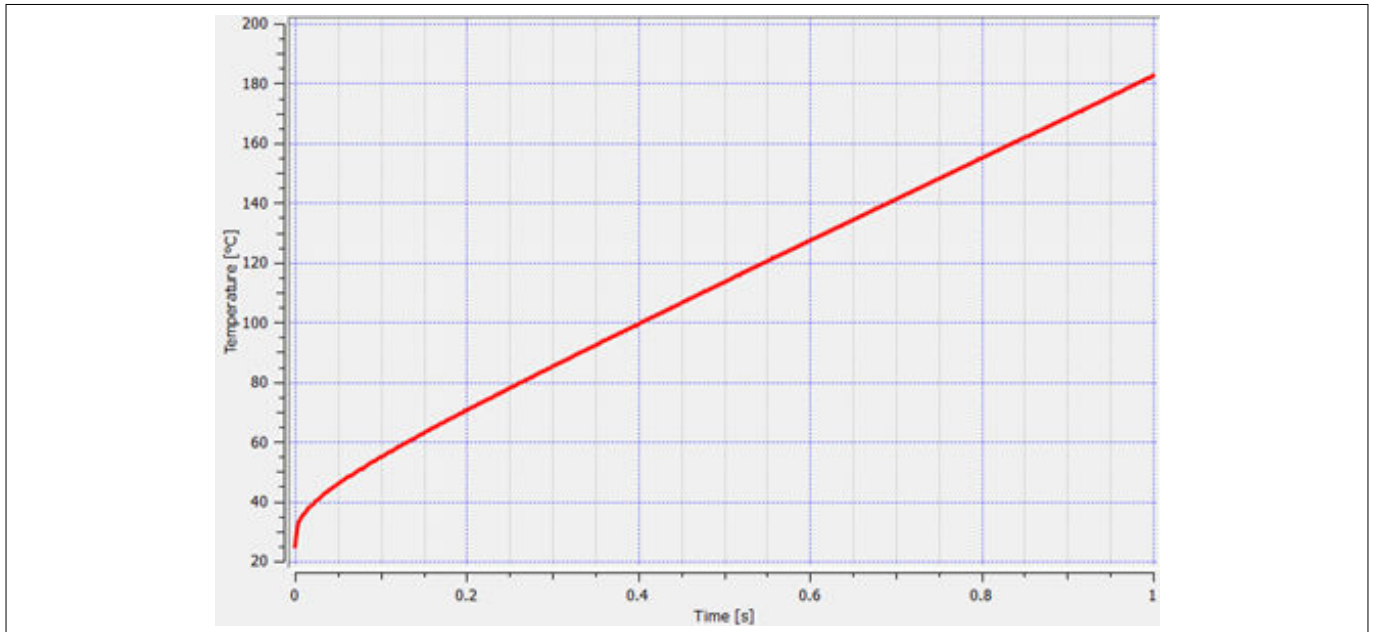

Figure 9 Thermal simulation in stall condition (250 A) assuming a 4-layer PCB (JEDEC 2s2p)

When the switch OFF is triggered by the over temperature protection, the junction temperature of the MOSFET at the beginning of the demagnetization is above 150°C, which shifts the smart clamping voltage to roughly $V_{DS(CL)} = 42$ V.

The demagnetization energy can be calculated because of the following equation and the associated parameters values:

$$E = V_{DS(CL)} \times \frac{L}{R_L} \times \left[\frac{V_S - V_{DS(CL)}}{R_L} \times \ln \left(1 - \frac{R_L \times I_L}{V_S - V_{DS(CL)}} \right) + I_L \right]$$

Equation 2

Where: $V_{DS(CL)} = 42$ V (due to the high temperature of the MOSFET); $L = 26$ μH; $R_L = 29$ mΩ; $V_S = 8$ V (due to the voltage drop in the battery output resistance); $I_L = 250$ A.

The result is: $E = 880$ mJ.

Looking at the EAS curve from the datasheet [\[1\]](#), it is visible that this level of energy can damage BTS50010-TAE:

3 Driving a small ICE starter motor (< 150 cc)

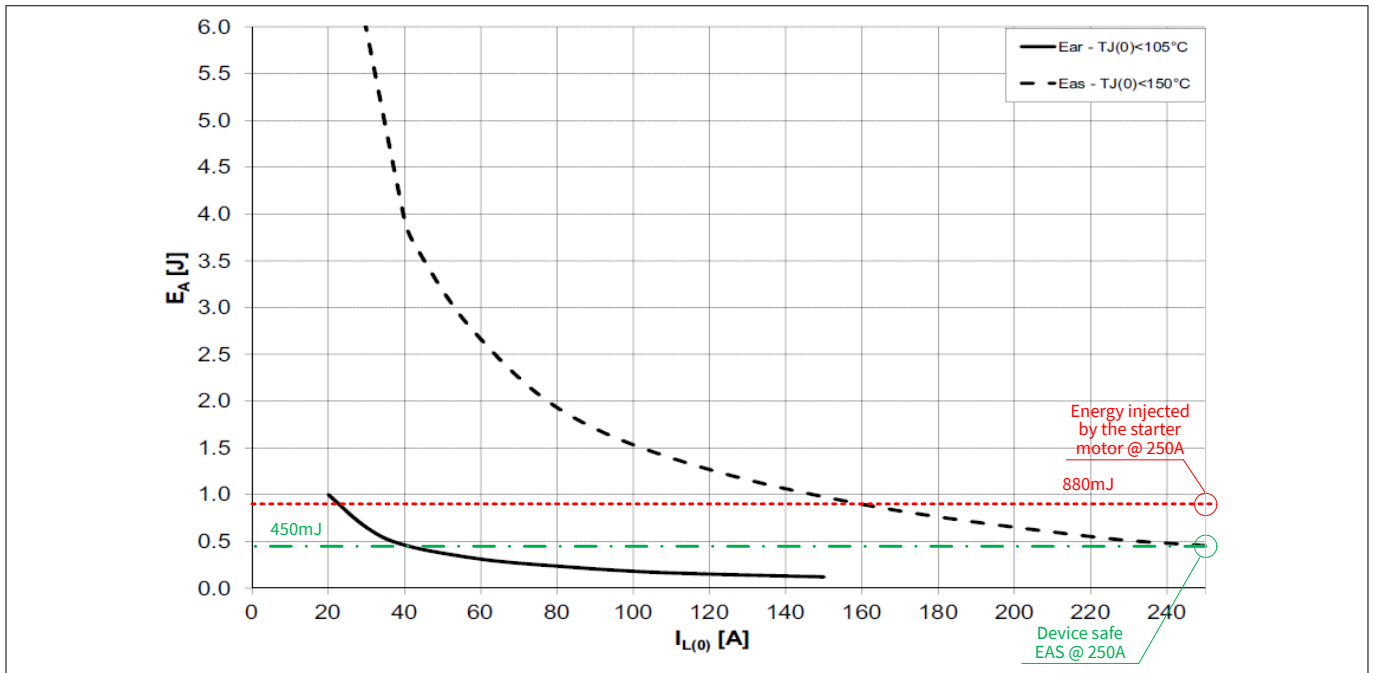

Figure 10 Checking the safety margin at 250 A

This is only an example based on the characteristics of the starter motor used here in the tests and simulating a stall current of 250 A. It may be that with other motor characteristics (inductance, resistance, stall current), the component is in the safe operating area for EAS.

For instance, recomputing the energy if the maximum stall current is changed from 250 A to 200 A, every other parameter remaining unchanged, and the energy injected in the MOSFET becomes 580 mJ at 200 A:

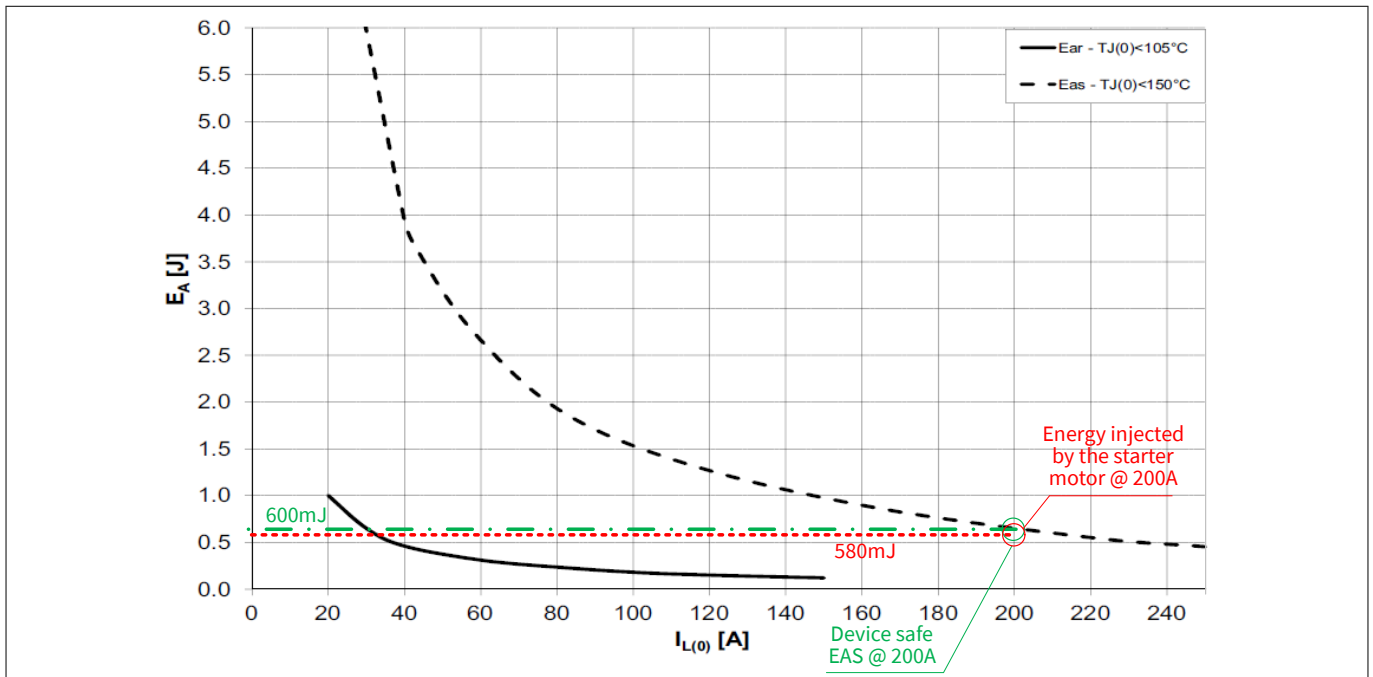

Figure 11 Checking the safety margin at 200 A

This time, the device is safe, the energy injected is smaller than the maximum EAS specified at 200 A. Back to the scenario with 250 A, since the device can be damaged, it is necessary to add external protections. The target with such protections is to offload part of the demagnetization energy from BTS50010-1TAE.

3 Driving a small ICE starter motor (< 150 cc)

The proposal is to use a bi-directional Transient Voltage Suppressor (TVS) between the MOSFET drain (*VS* pin) and the MOSFET source (*OUT* pins). A series resistor is also added, to fine tune the sharing of the energy between the TVS and BTS50010-1TAE.

Table 3 shows the new application schematic with D_{Z2} and R_{Z2} . (D_{Z1} has not yet been discussed: it will be described later on).

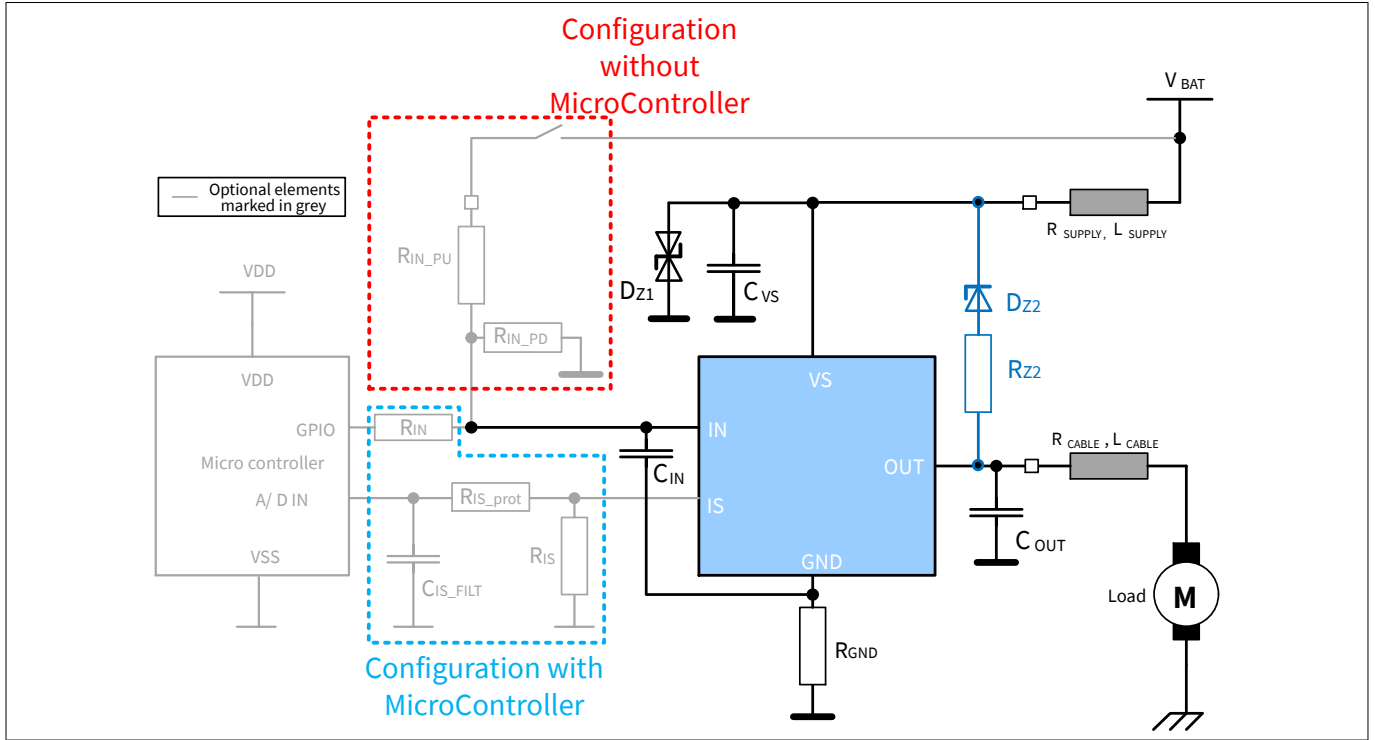

Figure 12 Application diagram with auxiliary drain-to-source snubber circuitry (R_{Z2} and D_{Z2})

The target now is to determine which TVS to select for D_{Z2} and which value to assign to R_{Z2} so that the energy is shared among the 3 devices and all of them are in their safe operating area.

The first step is to understand better how these two components behave: the smart clamping feature of BTS50010-1TAE and the TVS both behave as an ideal zener diode in series with a low-ohmic resistor; since an external resistor (R_{Z2}) is added in series with the TVS, the equivalent schematic is:

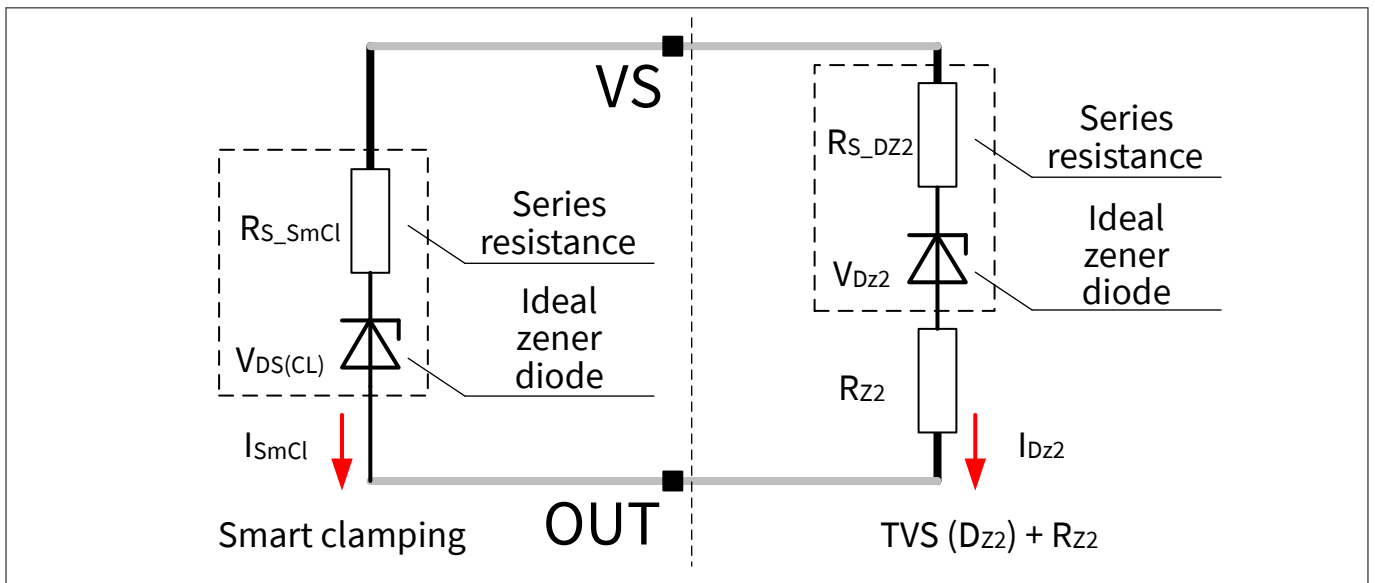

Figure 13 Equivalent schematic for the smart clamping and the TVS

3 Driving a small ICE starter motor (< 150 cc)

Since the smart clamping feature of BTS50010-1TAE and the network formed by the TVS (D_{Z2}) and R_{Z2} are connected in parallel, the current will be shared between the two networks. To know how much current is flowing in each branch, we can use the following equations:

$$I_{Motor} = I_{SmCl} + I_{Dz2}$$

Equation 3

$$V_{Dz2} + R_{Z2} = V_{SmartClamp}$$

Equation 4

and

$$V_{SmCl(0)} + I_{SmCl} \times R_{S_SmCl} = V_{Dz2} + I_{Dz2} \times (R_{S_Dz2} + R_{Z2})$$

Equation 5

derived from the equation [Equation 4](#) above.

The following equation is derived from [Equation 3](#) and from [Equation 5](#):

$$I_{Dz2} = \frac{(V_{SmCl} - V_{Dz2}) + R_{S_SmCl} \times I_{Motor}}{(R_{S_Dz2} + R_{Z2} + R_{S_SmCl})}$$

Equation 6

Once we know I_{Dz2} , we can calculate:

$$I_{SmCl} = I_{Motor} - I_{Dz2}$$

Equation 7

Some of the parameters have a known value:

- $I_{Motor} = 250$ A
- $V_{DS(CL)} = 40$ V (due to the high temperature of the MOSFET at high current)
- $R_{S_SmCl} = 35$ mΩ

For the TVS, the “zener” voltage has to be selected; there are a lot of references available in the market, usually in steps of 3 V. The target is to have a voltage in the range of the nominal value of $V_{DS(CL)}$, so that the two networks are sharing current. V_{Dz2} will very likely be in the [30;35] V range where the typical value for R_{S_Dz2} is $R_{S_Dz2} \approx 100$ mΩ.

We now have to tune the values of V_{Dz2} and R_{Z2} . Using [Equation 6](#) and [Equation 7](#), it is possible to build a calculation model which calculates the current flowing in each branch during the demagnetization and to check the resulting energy (integrating the power dissipated in each device over the demagnetization time).

The current discharge profile is extracted from data sampled with an oscilloscope and an excel worksheet computes the current sharing along this profile based on [Equation 6](#) and [Equation 7](#).

3 Driving a small ICE starter motor (< 150 cc)

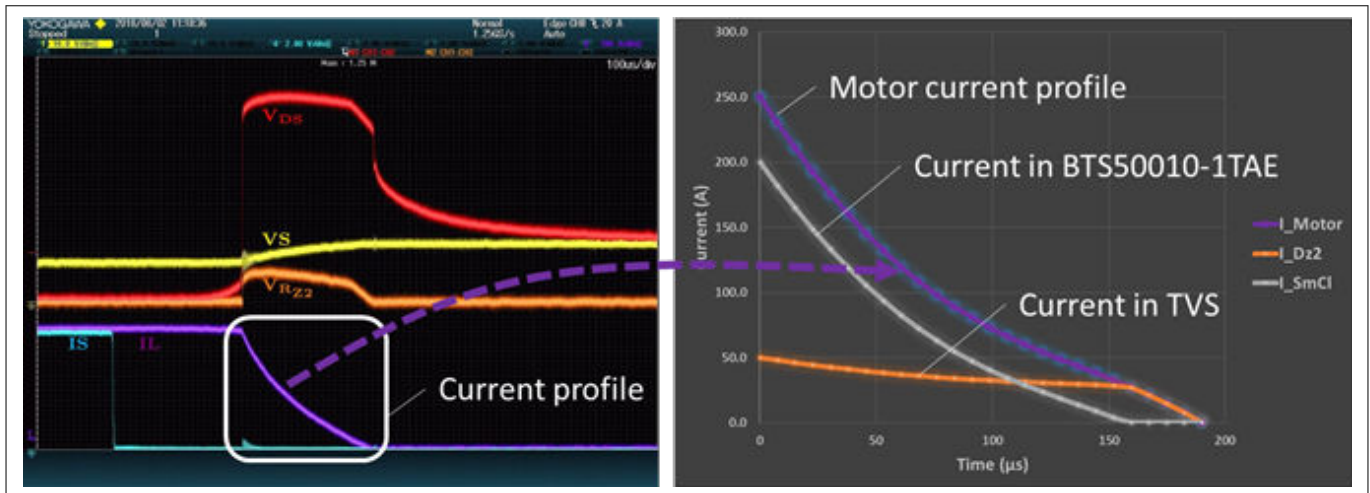

Figure 14 Extraction of the current profile and usage in the excel worksheet

Playing with the 2 parameters V_{Dz2} and R_{Z2} , we can have a look at the current sharing:

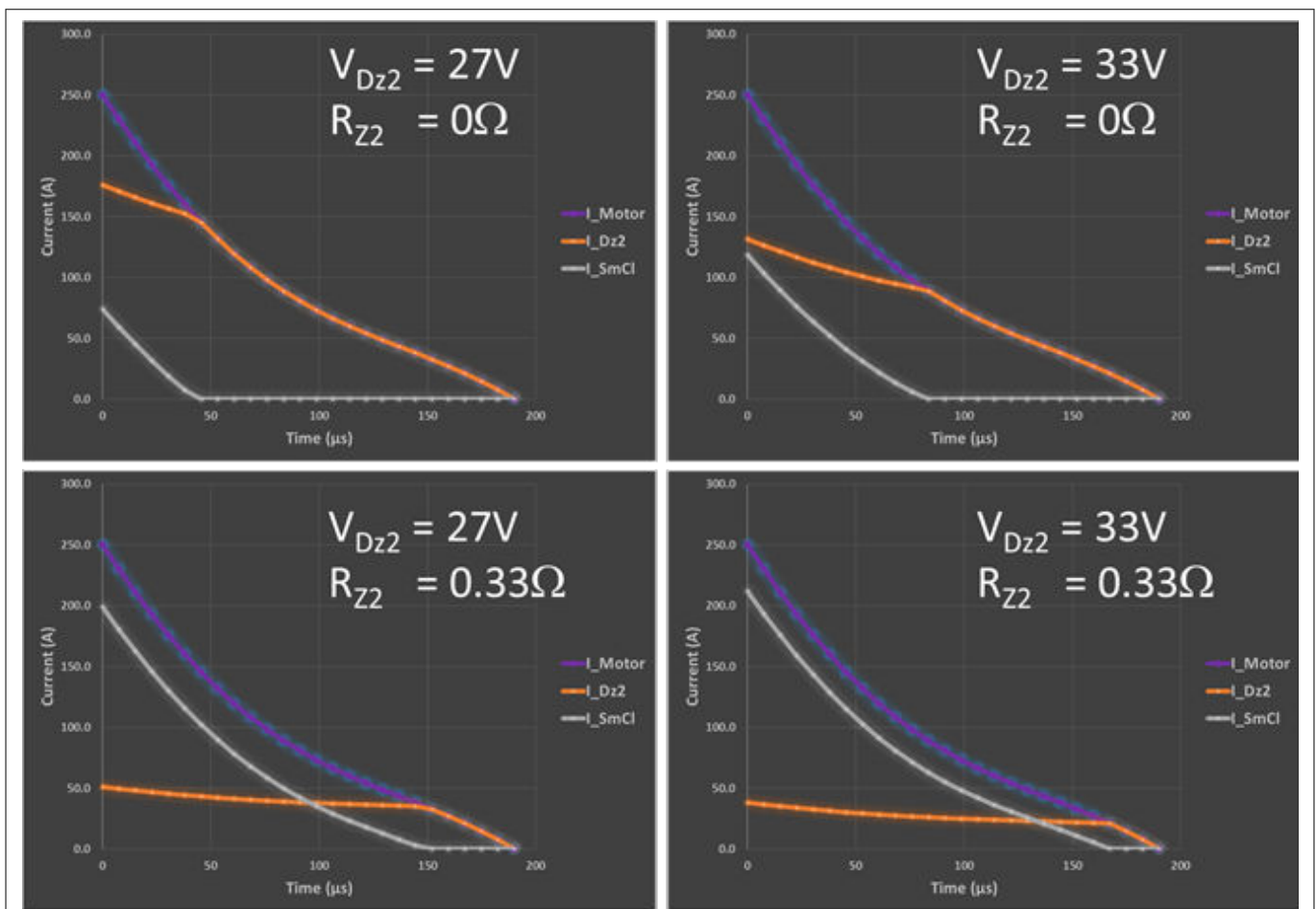

Figure 15 Influence of D_{z2} and R_{z2}

These curves show the very big influence of R_{z2} : from $R_{z2} = 0 \Omega$ to $R_{z2} = 0.33 \Omega$, the split is significantly changed, from a current flowing mainly through the TVS (orange curves) or mainly through the BTS50010-1TAE smart clamping (grey curves).

Additional calculation allows to also compare the energy sharing for R_{z2} in the range $[0;0.35] \Omega$:

3 Driving a small ICE starter motor (< 150 cc)

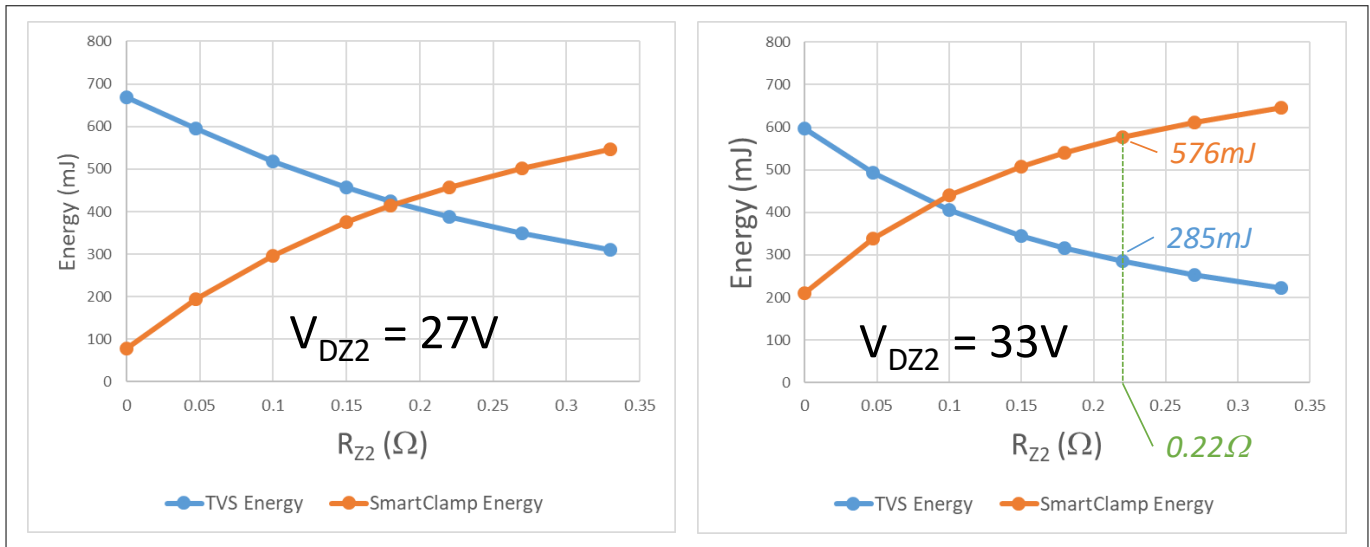

Figure 16 Energy sharing between the TVS and the BTS50010-1TAE smart clamping

The decision has been to use $V_{DZ2} = 33V$ and $R_{Z2} = 0.22\Omega$, since it puts BTS50010-1TAE slightly below the EAS = 600 mJ limit at 200 A, as already described, and limits the energy in the TVS to a safe level (below 300 mJ). Based on this setting, the final current sharing from the calculation model is as follows:

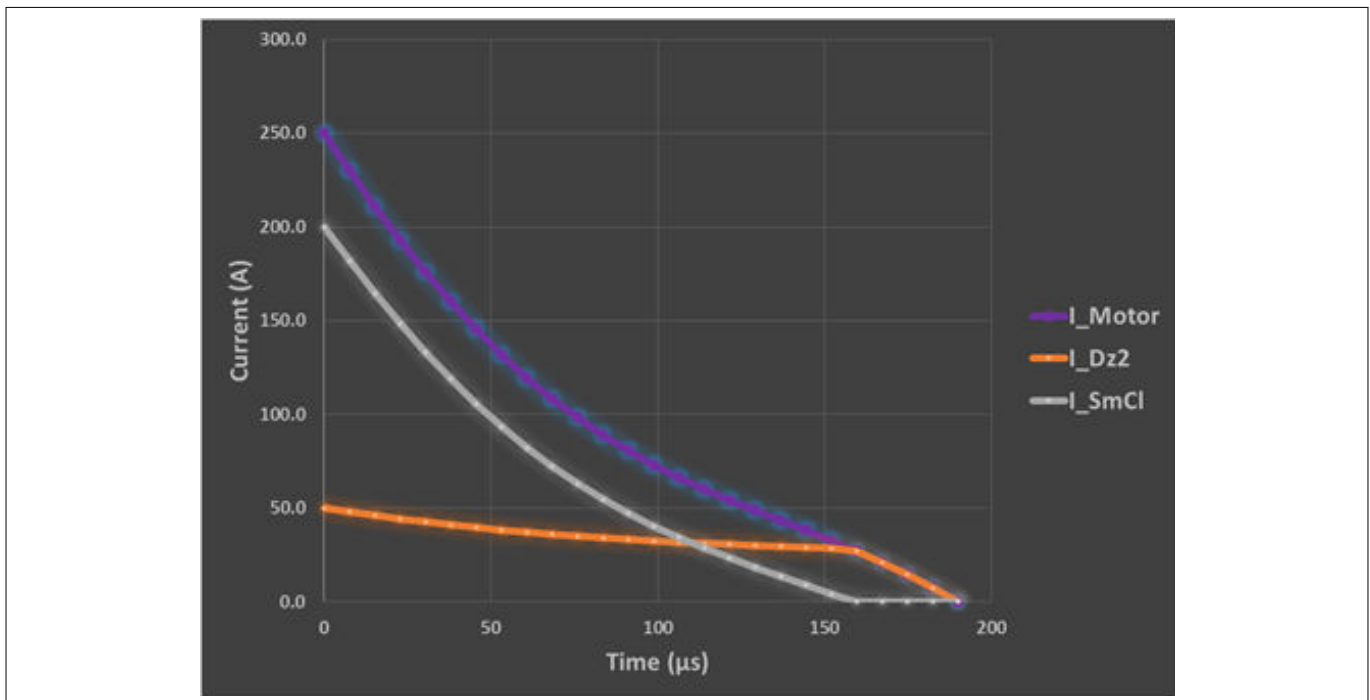

Figure 17 Current in the smart clamping and in the TVS for $V_{DZ2} = 33V$ and $R_{Z2} = 0.22\Omega$

The current in the BTS50010-1TAE is limited to 200 A at the beginning of the demagnetization while the TVS gets 50 A. It is visible that when the motor current is below 25 A (after 160 μs), only the TVS conducts some current. Coming back to the lab measurement, the curve showing the current in the TVS (V_{RZ2} , which is the voltage across R_{Z2}) shows a waveform close to the one calculated, which shows the validity of the model.

3 Driving a small ICE starter motor (< 150 cc)

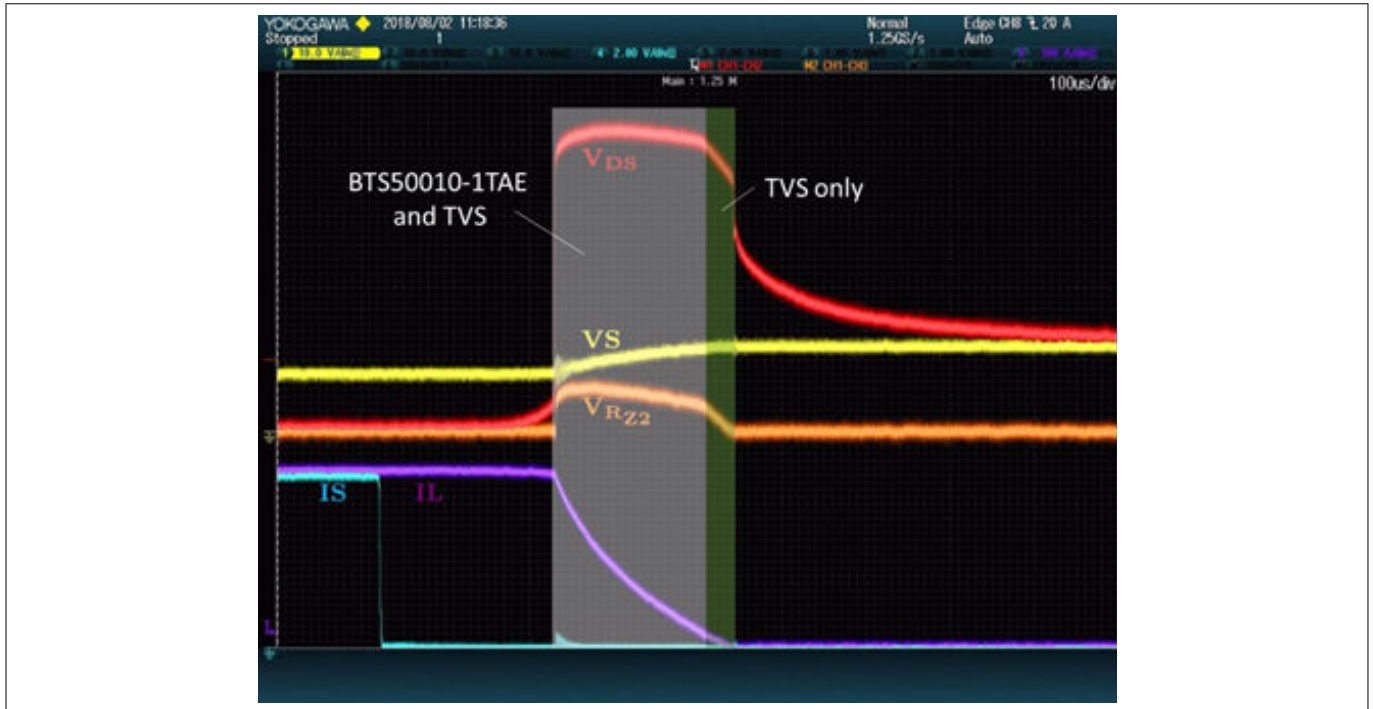

Figure 18 Application waveforms for the BTS50010-1TAE switching-off transition

The fast decline on the VDS voltage can be explained by the $V = f(I)$ curves of each of the devices: **Figure 19** shows these curves with $V_{DZ2} = 33\text{ V}$ and $R_{Z2} = 0.22\ \Omega$.

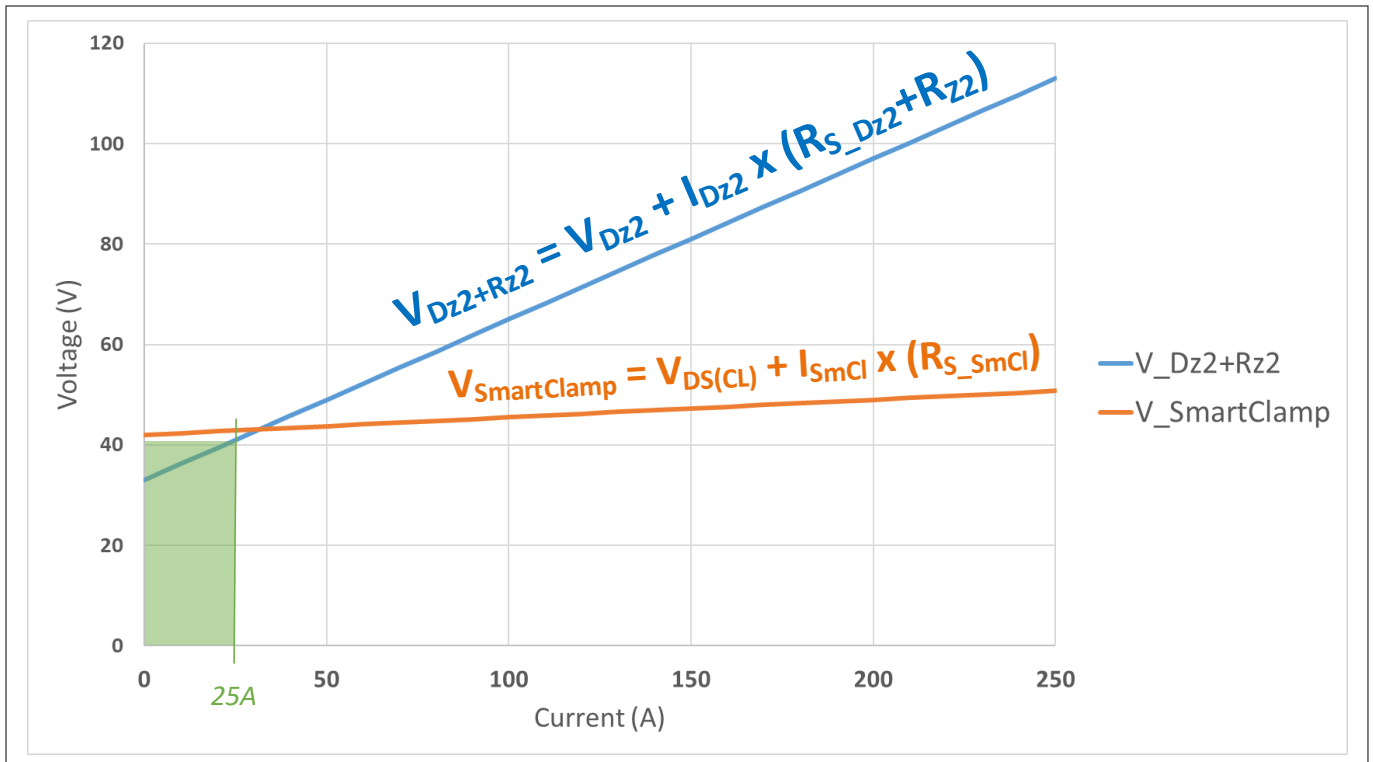

Figure 19 $V = f(I)$ curves for the smart clamping and the TVS

Below 25 A, the voltage on the network formed by $D_{Z2} + R_{Z2}$ is always below the $V_{DS(CL)}$ voltage of BTS50015-1TAE: all the current is flowing through the TVS and the voltage is declining together with the current based on a higher slope ($R_{S_Dz2} + R_{Z2} \approx 0.32\ \Omega$) compared to the slope when the BTS50010-1TAE is deriving most of the current ($R_{S_SmCl} = 0.035\ \Omega$).

3 Driving a small ICE starter motor (< 150 cc)

It is also worth mentioning here that the two components together (BTS50010-1TAE + TVS) will bring a nice load dump filtering feature on the motorcycle: indeed, in case of a load dump on the battery line, the voltage will be limited through these 2 components in series with the motor resistor.

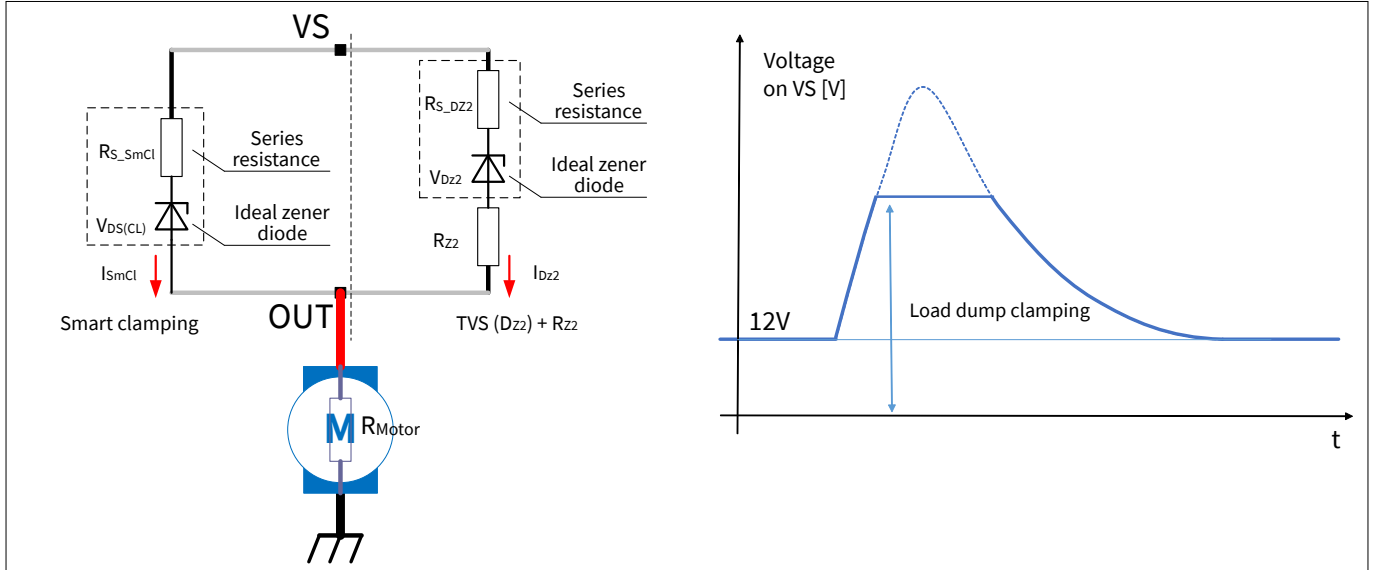

Figure 20 Load dump clamping

3.5 Current sensing

The BTS50010-1TAE provides a current sense signal at pin *IS*.

As long as no failure mode occurs (short circuit on *OUT* pin to ground / overcurrent / over temperature) and the condition $V_{IS} \leq V_{OUT} - 5V$ is fulfilled, a signal proportional to the load current is provided.

The complete *IS* pin and diagnostic mechanism is described in section 5.4.3 of the device datasheet [1].

A simplified diagram of the analogue current sense circuitry implemented in the BTS50010-1TAE is illustrated in the **Figure 21**.

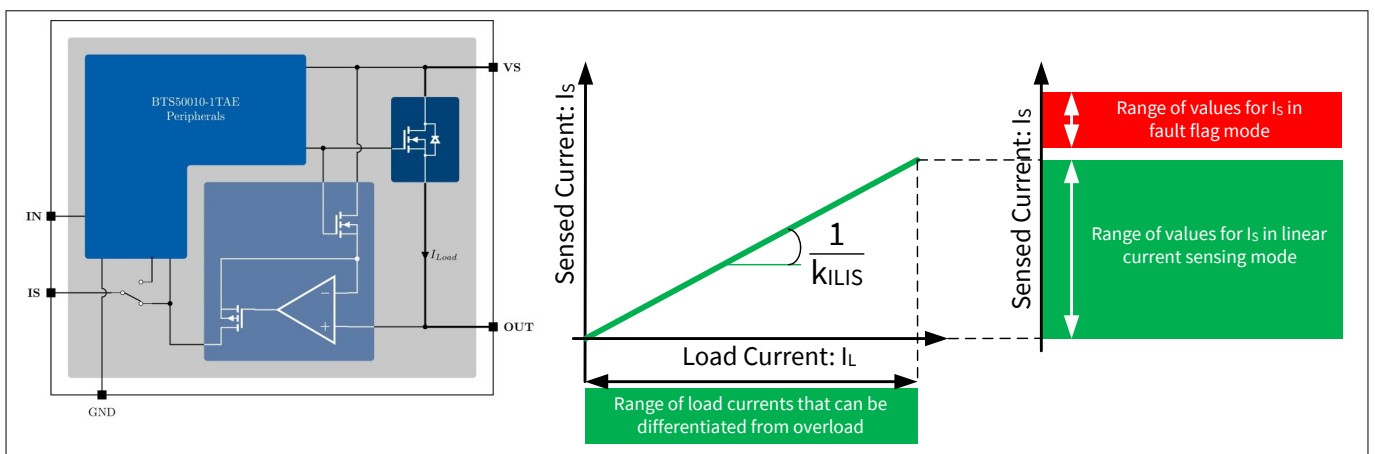

Figure 21 Current sensing circuit in BTS50010-1TAE

Ideally, the analog current sense diagnosis should reflect the load current without any additional error. However, in reality, the *IS* analogue current sense diagnosis do always have an inherent inaccuracy associated. This is shown in **Figure 22** of the BTS50010-1TAE datasheet [1]:

3 Driving a small ICE starter motor (< 150 cc)

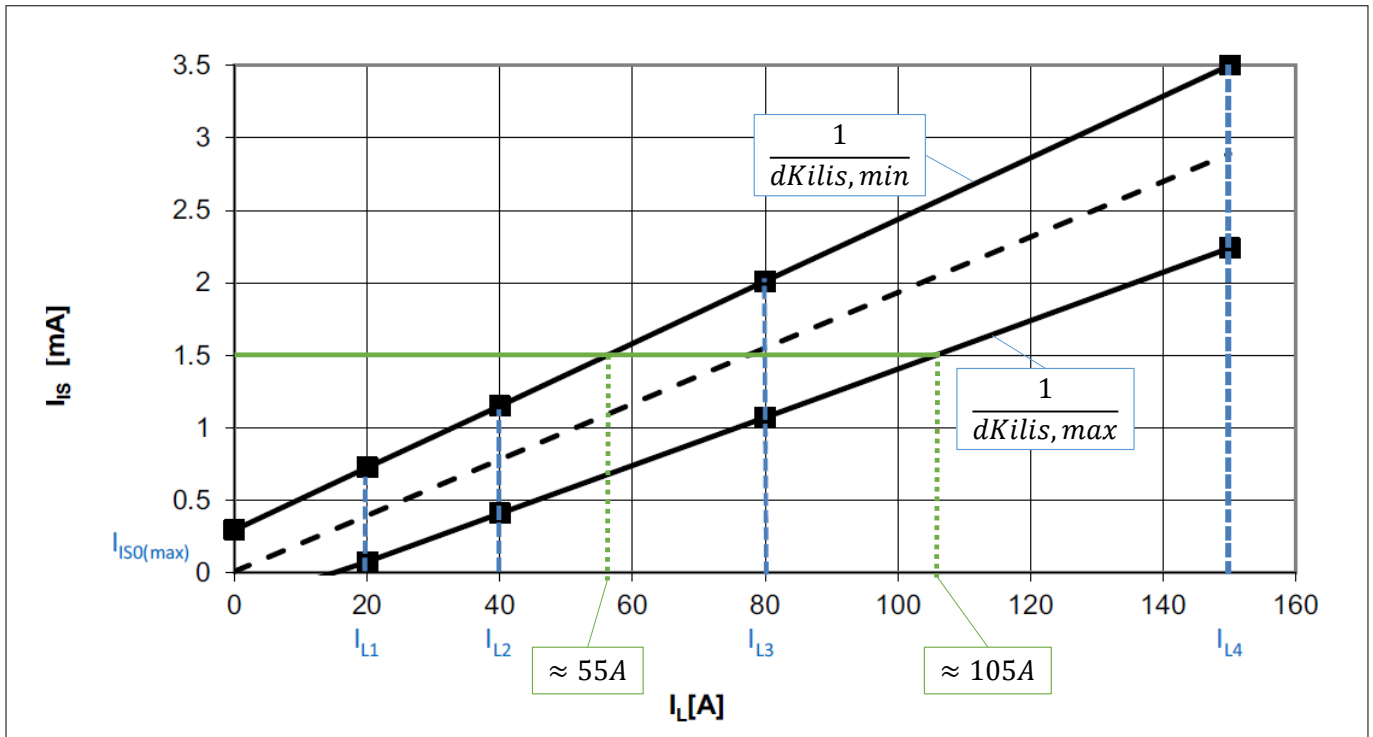

Figure 22 Sense current as a function of the load current

As an example, when the IS pin delivers a current of 1.5 mA, the corresponding load current I_L is between 55 A and 105 A. To improve the accuracy of the current sense feature, a calibration is necessary. The application note "Power PROFET™ Improved SENSE Calibration and Benefits Guide" [2] details how to proceed and what level of performance can be achieved using a 1-point or a 2-point calibration procedure.

Note: The sense feature is guaranteed to be linear until 150 A; since the load current can go up to 250 A without triggering the overcurrent protection, a saturation might be observed on the IS pin for a load current between 150 A and 250 A.

3 Driving a small ICE starter motor (< 150 cc)

3.6 Undervoltage protection

More than providing a one-to-one replacement for the traditional electromechanical relay, the Infineon Power PROFET™ provides additional useful features for the application.

One of them is the undervoltage protection.

To test this feature, the same set up as the one described in [Chapter 3.2](#) is used here. The bank of resistors is used to increase the emulated battery output impedance, so that V_S drops below the undervoltage threshold (5 V typical).

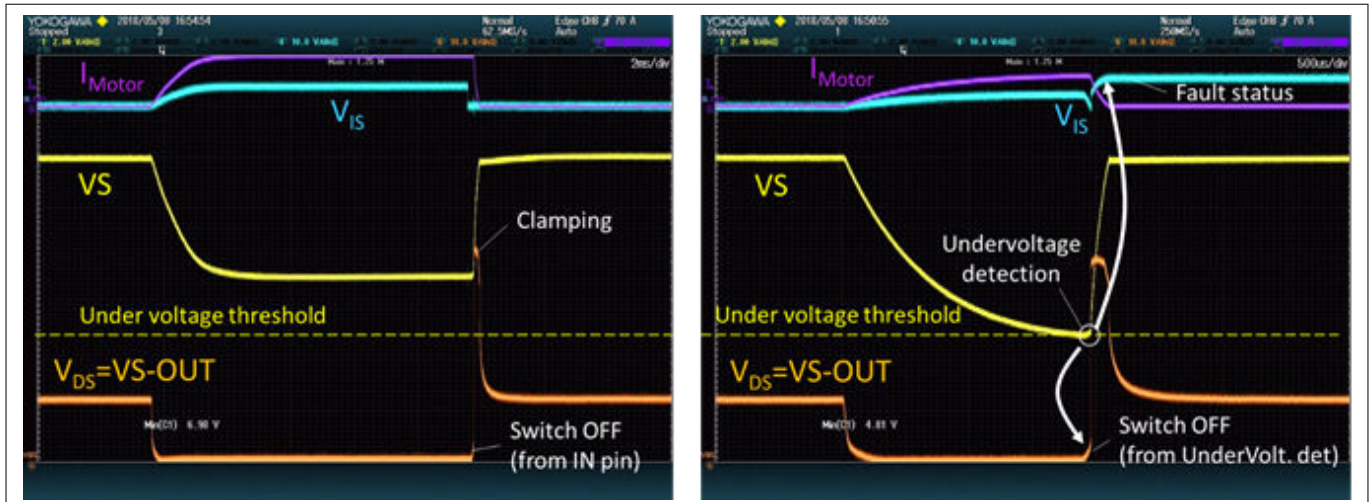

Figure 23 Activation of BTS50010-1TAE without (left) and with (right) under voltage triggering

When the conditions to trigger an undervoltage are met, the sequence is as follows:

1. BTS50010-1TAE is exposed to a V_S voltage which drops below the undervoltage threshold (5 V typical)
2. The internal power MOSFET is immediately switched OFF, which generates a demagnetization phase
3. The *IS* pin reports a fault status and BTS50010-1TAE is latched in OFF mode

To exit the latched-OFF mode, a reset sequence has to be applied on the *IN* pin (*IN* low for $t > t_{IN(RESETDELAY)}$).

3 Driving a small ICE starter motor (< 150 cc)

3.7 Battery disconnection

The BTS50010-1TAE datasheet [1] in section 5.3.2 describes the recommended circuit to protect the device in case of loss of battery.

The target here is to help to size the recommended Transient voltage suppressor, since it is used to demagnetize the starter motor.

Figure 24 illustrates how the TVS helps to protect BTS50010-1TAE: in step 1, the battery is connected and the current flows from the battery to the starter motor and then back to the battery through the ground/chassis connection. Step 2 shows that when the battery connection is lost, the demagnetization current will entirely flow through the BTS50010-1TAE driver, which is not designed to survive the very high energy stored in the starter motor. Step 3 describes how adding a TVS ensures that all the demagnetization current is routed away from BTS50010-1TAE, thus keeping it safe.

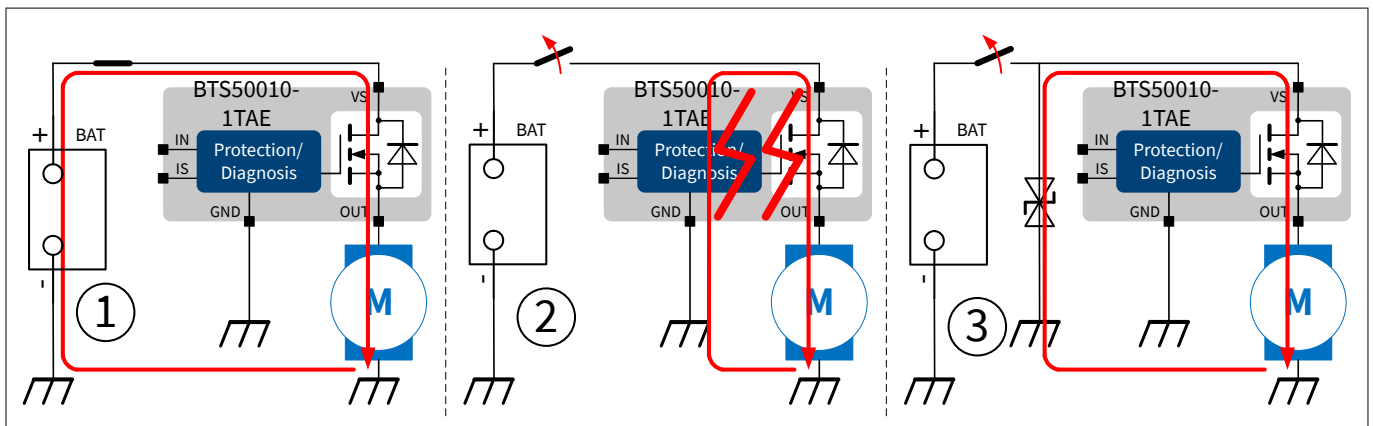

Figure 24 Current flow when the battery connection is lost

The Figure 25 and Figure 26 show the test results in the lab; first with a short cut of the VS supply (10 μs) and then with a permanent switch OFF. It can be seen on the zoom that the MOSFET is initially turned ON, but during the supply loss, the MOSFET is turned OFF due to the under voltage protection described in Chapter 3.6. The smart clamping feature is then visible on the V_{DS} curve (pulse of 35 V). Whatever the scenario, the MOSFET remains latched OFF at the end: a reset sequence has to be applied on the IN pin (IN low for t > t_{IN(RESETDELAY)}) to unlatch it.

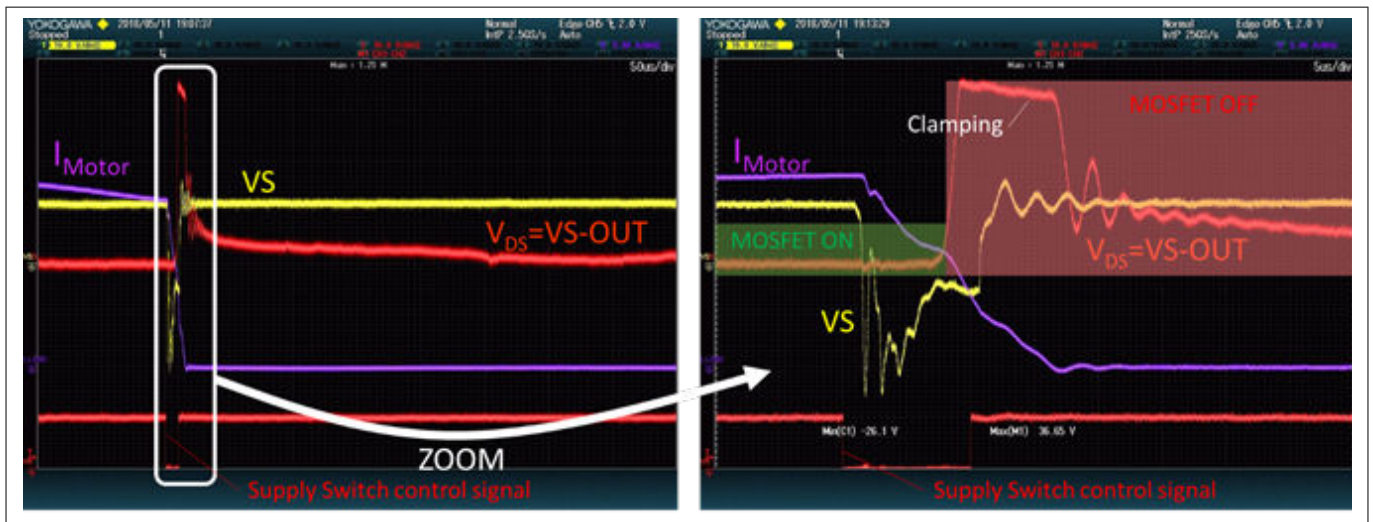

Figure 25 Short disconnection of the power supply line (10 μs)

3 Driving a small ICE starter motor (< 150 cc)

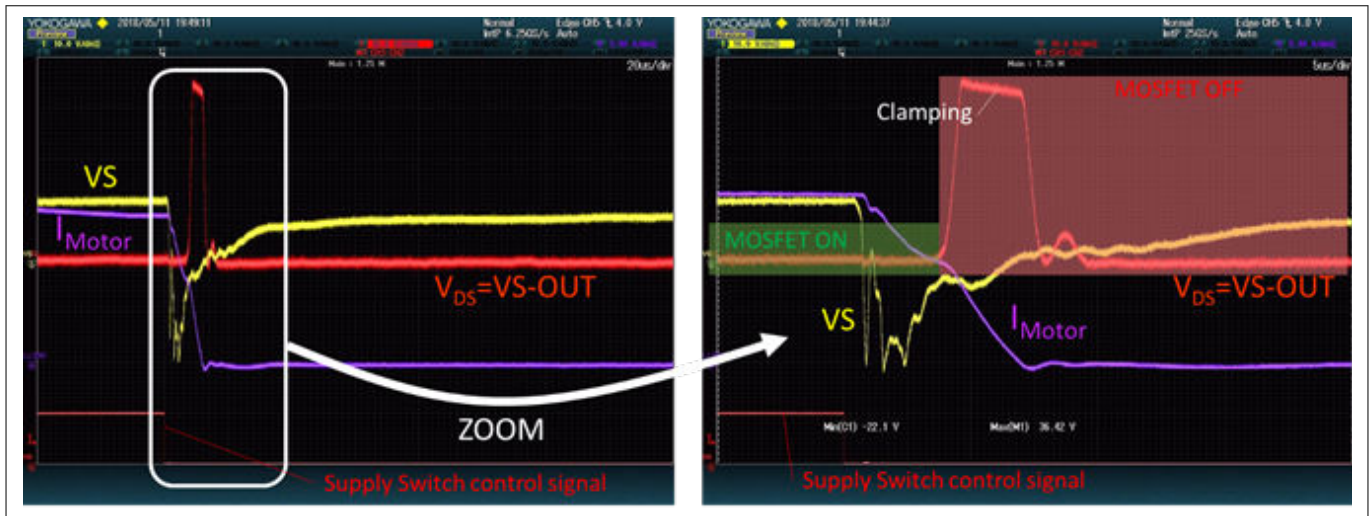

Figure 26 Permanent disconnection of the power supply line

3 Driving a small ICE starter motor (< 150 cc)

3.8 Reverse battery protection

All the members of the Power PROFET™ family come with a reverse battery protection feature, which is targeted at protecting the PROFET™ itself.

The power MOSFET comes with a body diode which will unfortunately allow the current to flow through the load during battery polarity reversal (reverse battery). The MOSFET is then jeopardized since the power losses are much higher when the current flows through the body diode rather than through the MOSFET itself.

The protection for the MOSFET here consists in switching it ON when the control circuitry detects a reverse battery connection. Indeed, the power losses in the diode are in the order of: $P_{Diode} \approx 1\text{ V} \times I_{Motor}$ which would be $P_{Diode} \approx 40\text{ W}$ if $I_{Motor} = 40\text{ A}$ while these losses are $P_{MOS} = R_{DS(ON)} \times I_{Motor}^2$ which would be $P_{MOS} \approx 3.52\text{ W}$ for the same $I_{Motor} = 40\text{ A}$, with $R_{DS(ON)} = 2.2\text{ m}\Omega$ which is the worst case $R_{DS(ON)}$ for BTS50010-1TAE when the junction temperature is 150°C and the device is in reverse mode (see parameter P_6.1.30 in the device datasheet [1]).

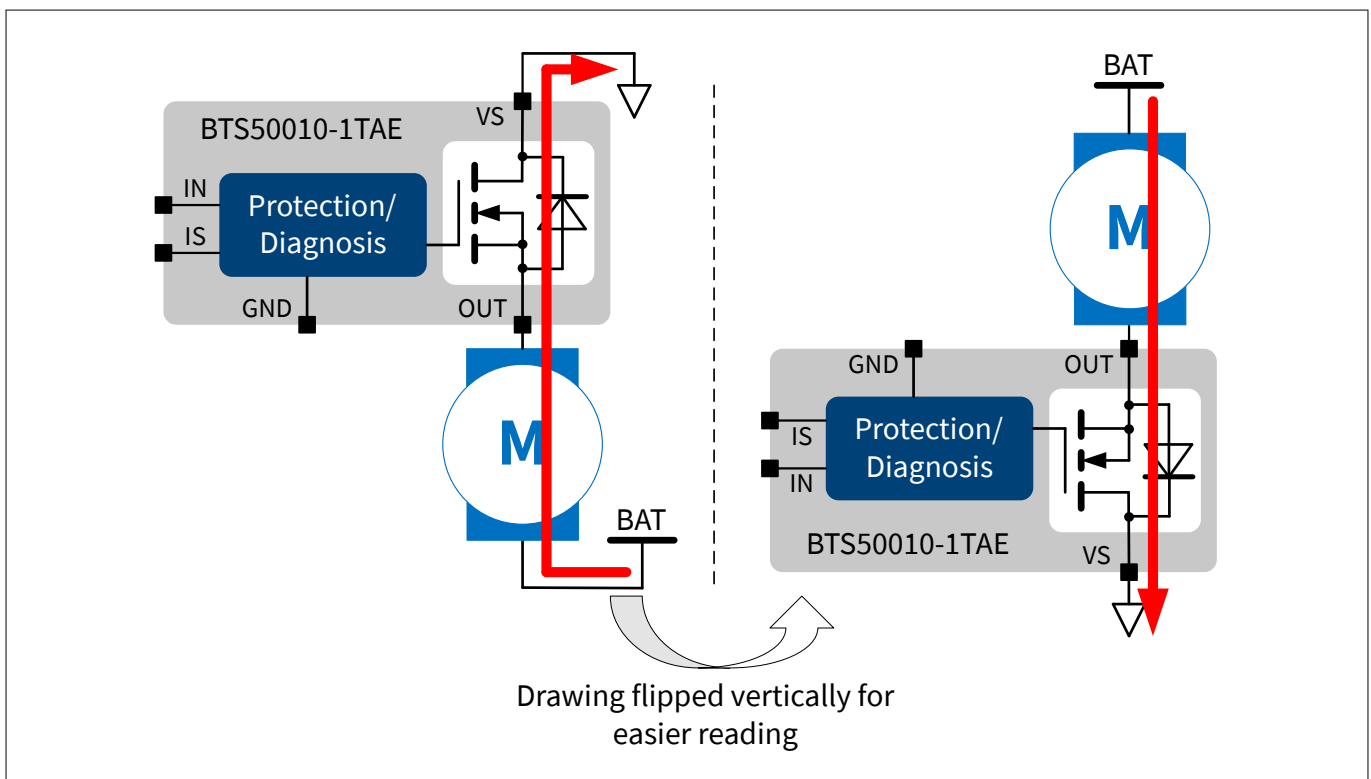

Figure 27 Reverse battery connection: regular drawing (left), vertically flipped drawing (right)

This protection only applies to the MOSFET, not to the load itself. Indeed, the load is still exposed to the battery voltage, in reverse polarity, so the starter motor will run backward which is not an issue since there is a mechanical protection between the starter motor and the ICE for such a scenario.

The most critical scenario in reverse battery is when the supply connection is temporary lost: there is some current in the motor, which needs to be demagnetized. This scenario is very similar to the one described in Chapter 3.7. The main difference is the battery polarity and the resulting current direction. This is why the protection device (TVS) is a bi-directional device, to be able to protect for the two possible current directions.

Figure 28 illustrates how the TVS helps to protect BTS50010-1TAE: in step 1, the current flows from the starter motor to the battery through BTS50010-1TAE and then back to the motor through the ground/chassis connection. Step 2 shows that when the battery connection is lost, the demagnetization current will entirely flow through the BTS50010-1TAE driver, which is not designed to survive the very high energy stored in the starter motor. Step 3 describes how the TVS is deriving all the demagnetization current from BTS50010-1TAE, thus keeping it safe.

3 Driving a small ICE starter motor (< 150 cc)

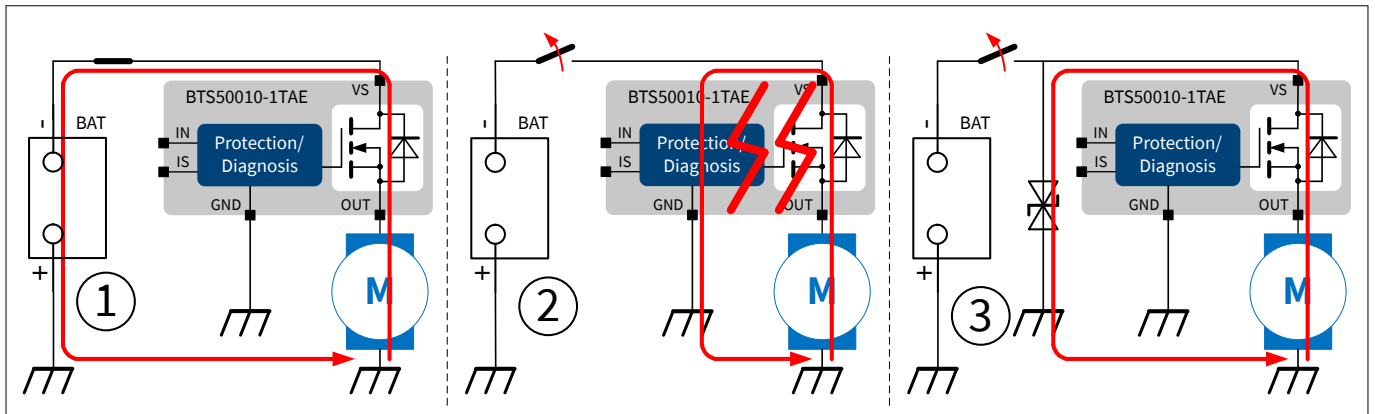

Figure 28 Current flow when the battery connection is lost in reverse battery polarity

The energy stored can be very high, if the loss of connection happens during the starter motor inrush/stall current. In order to limit the stress on the TVS, a ground resistor is added (R_GND2, see [Figure 29](#)), which dissipates part of the energy.

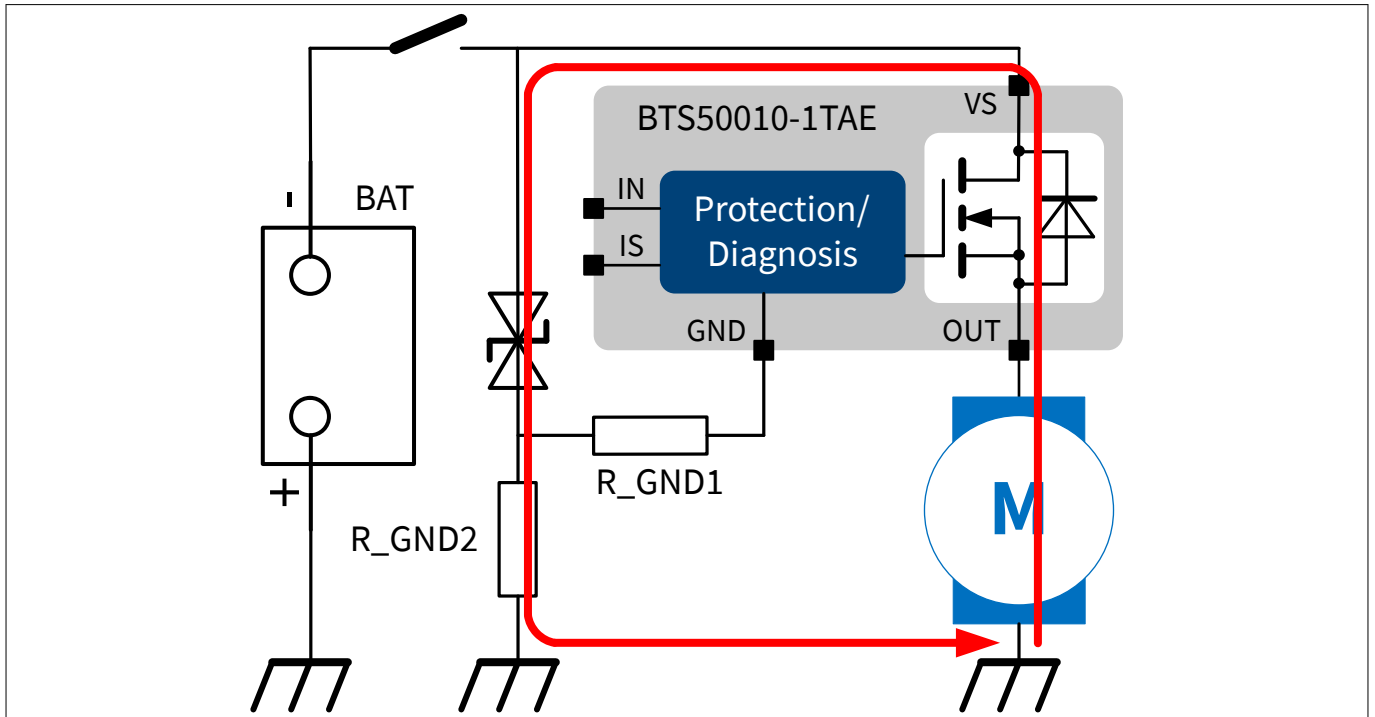

Figure 29 Additional resistors to limit the energy in the TVS

4 Practical considerations

4 Practical considerations

4.1 ECU integration (space estimation)

Due to regulations, there is a clear trend to move ICEs to clean Electrical Fuel Injection systems (EFI), which require an ECU. An example for such an ECU is described on the **Figure 30**:

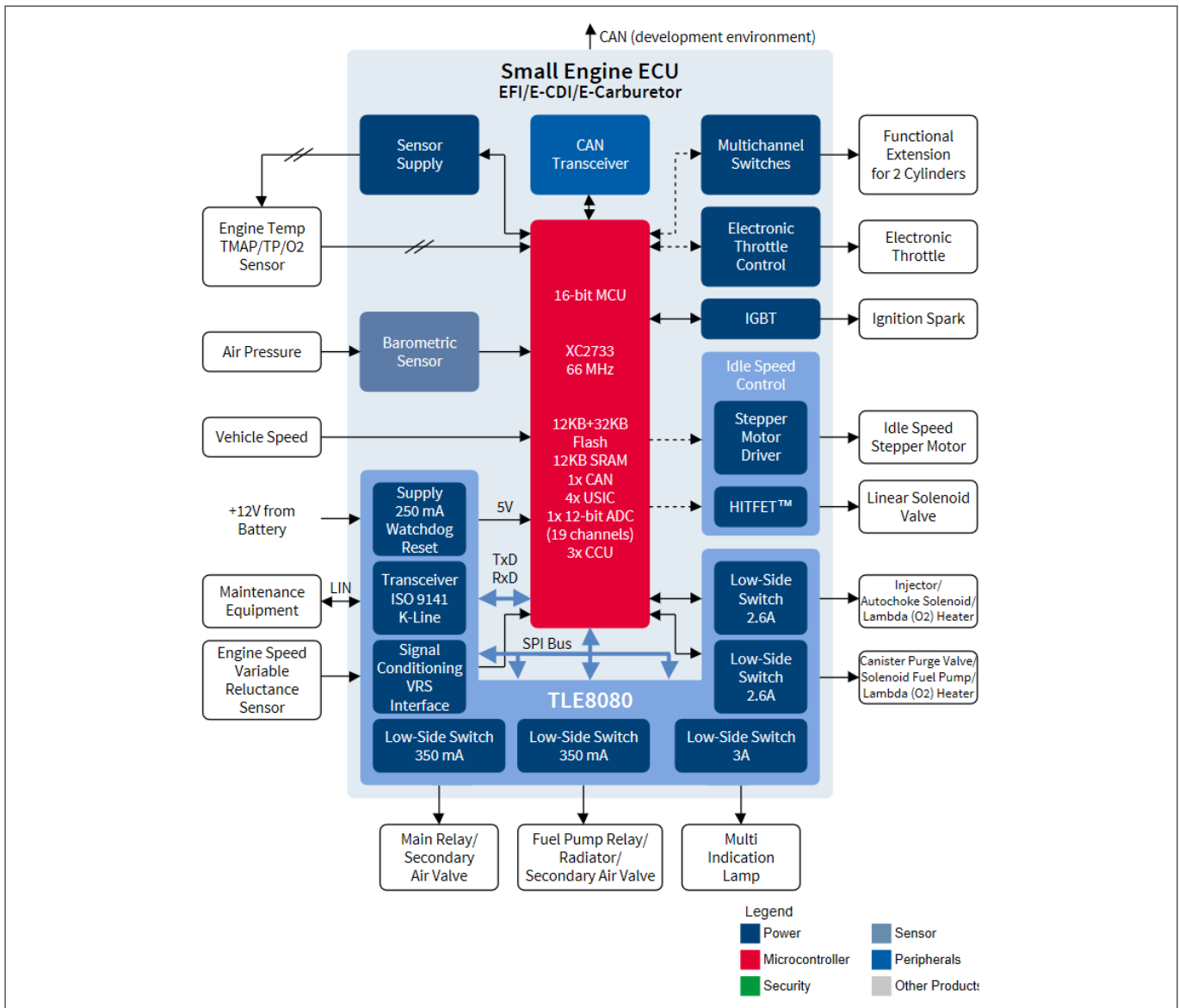

Figure 30 Block diagram of a small engine ECU based on Infineon components

This ECU can embed the BTS50010-1TAE.

It is necessary then to use power connectors which will be able to sustain the very high inrush current of the starter motor.

Connecting cables for the power lines require special care: here also the high inrush current implies to use an appropriate section for the wiring.

Figure 31 highlight (thick red) the wires from the positive terminal of the battery to BTS50010-1TAE VS pin and from BTS50010-1TAE OUT pin to starter motor positive terminal. These wires have to be sized in an appropriate manner:

4 Practical considerations

- The length of the two cables has to be limited such that in total the two wires represent less than 2 μH of parasitic inductance (roughly < 2 meters). This is required to limit the energy during demagnetization of the wires parasitic inductance in case of a short circuit between the starter motor and ground.
- The wires section has to be sized properly to match two requirements:
 - Limit the inrush current to 250 A. Assuming a battery voltage of 12 V, the overall resistance has to be minimum : $12/250 = 48 \text{ m}\Omega$, to keep the current below 250 A. For a starter motor resistance of 29 mΩ used in our tests, that means a wiring resistance of minimum : $48 - 29 = 19 \text{ m}\Omega$.
 - Limit the voltage drop seen by BTS50010-1TAE at start up so that the under voltage protection is not triggered (otherwise the ignition process would immediately stop). Since the undervoltage threshold is maximum 5.5 V, the maximum voltage drop in the wiring is : $12 - 5.5 = 6.5 \text{ V}$, which translates into a wiring series resistance of maximum: $[6.5/5.5] \times R_{\text{Mot}} = [6.5/5.5] \times 0.029 = 34 \text{ m}\Omega$.

As a summary, for an application with $V_{\text{BAT}} = 12 \text{ V}$ and $R_{\text{Mot}} = 29 \text{ m}\Omega$, the wiring series resistance has to be in the range $19 \text{ m}\Omega < R_{\text{Wiring}} < 34 \text{ m}\Omega$.

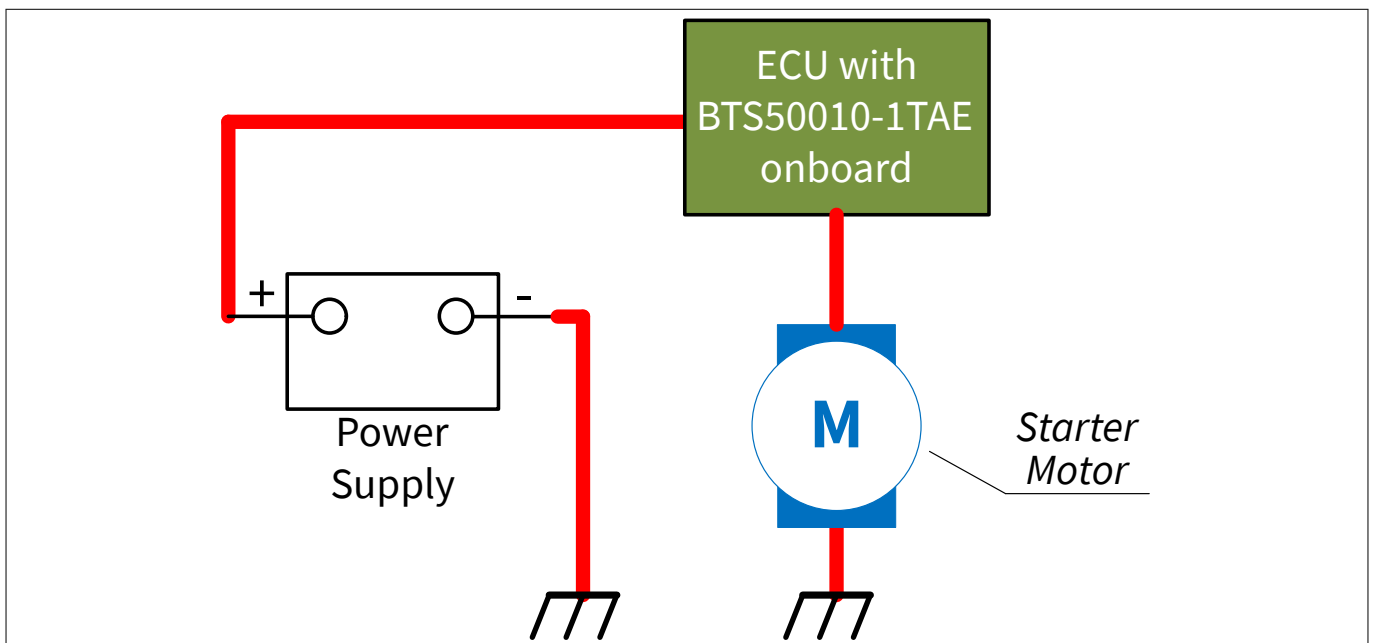

Figure 31 Power wiring diagram: the 4 red thick wires contribute to the total wiring resistance

4 Practical considerations

4.2 Demoboard

A demoboard is available for BTS50010-1TAE, which is designed in a very compact form factor (44.5 mm x 26.5 mm).

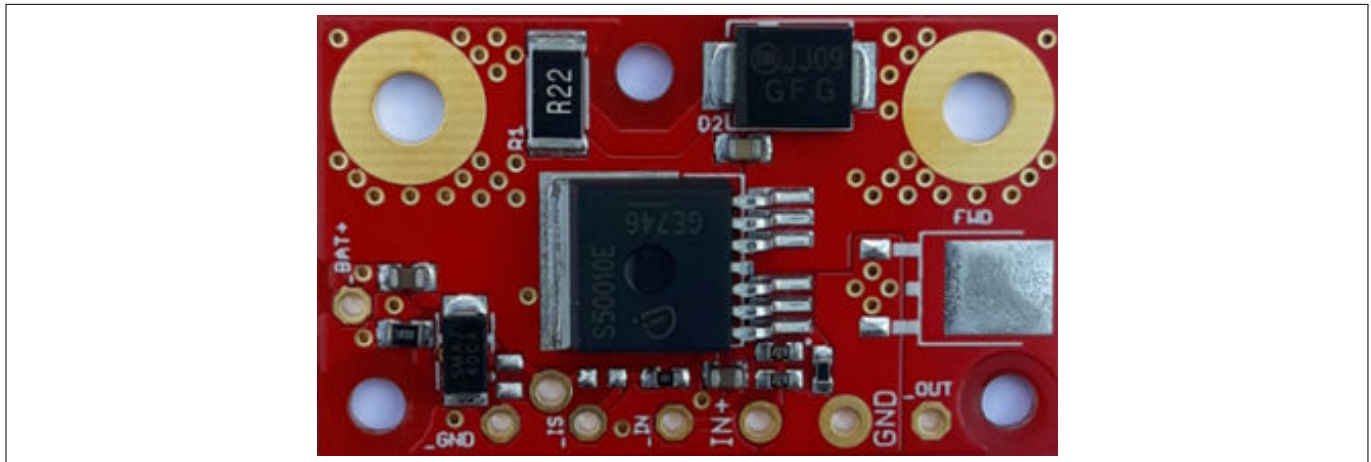

Figure 32 Demoboard picture

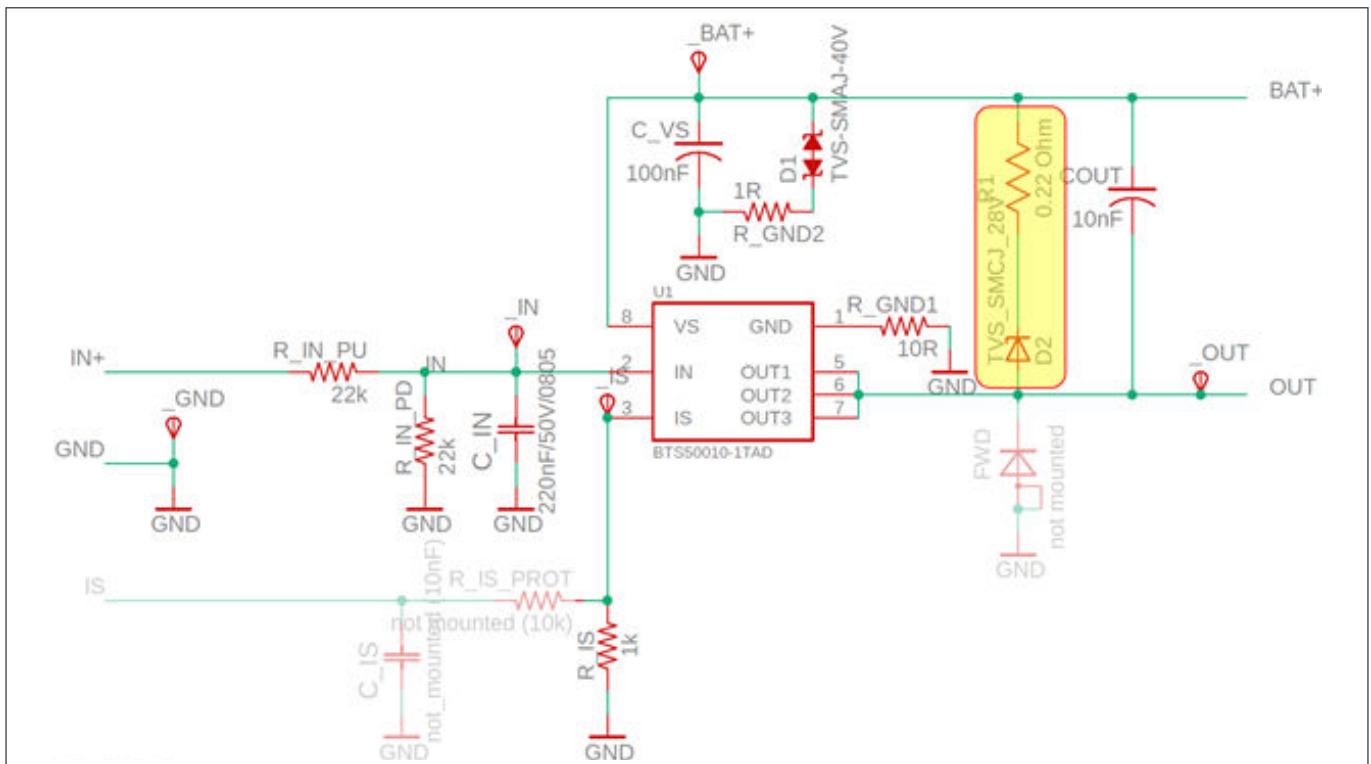

Figure 33 Schematic of the BTS50010-1TAE demoboard

The demoboard comes in two variants:

1. BTS50010-1TAE BOARD: standard version, where D2 and R1 (highlighted in yellow) are not assembled
2. BTS50010-1TAE DBTVS: D2 and R1 are assembled, to increase the energy capability during switch-OFF (see Chapter 3.4 for more details on the rationale to have D2 and R1)

Table 3 lists the bill of materials used on this demoboard:

4 Practical considerations

Table 3 **Bill of materials**

Reference	Value	Package	Purpose
R_GND1	10 Ω	0603	Protection in case of overvoltage and loss of battery while driving inductive loads
R_GND2	1.0 Ω	0805	Protection in case of overvoltage and loss of battery while driving inductive loads
D1	SMAJ40CA	SMA	Suppressor diode. Protection during overvoltage and in case of loss of battery
D2	SMCJ28CA	SMC	Suppressor diode. Additional protection during overvoltage for high inductive loads
R1	220 mΩ	2512	Snubber circuit or protection during overvoltage for high inductive loads
C_VS	100 nF	0805	Improved EMC behaviour (in layout, please place close to the pins)
COUT	10 nF	0805	Improved EMC behaviour (in layout, please place close to the pins)
C_IN	220 nF	0805	BTS50010-1TAE tends to latch switched-off due to short negative transients on supply pin; C/N automatically resets the device (for a 3.3 V or 5 V input signal)
RIN_PD	22 kΩ	0603	Fast discharge of C/N
RIN_PU	22 kΩ	0603	Protection of the microcontroller during overvoltage, reverse polarity. Allows BTS50010-1TAE to be OFF during loss of ground
R_IS	1 kΩ	0603	Sense resistor; if IS signal is not used, leave /S pin open

5 Reference list

1. [*BTS50010-1TAE datasheet*](#)
2. [*Application Note on Improved SENSE Calibration and Benefits Guide*](#)

6 Revision history

6 Revision history

Table 4 Revision history

Document version	Date of release	Description of changes
Rev. 1.00	2019-03-18	Initial application note
Rev. 1.10	2019-05-07	Changes restricted to text styles and minor typo corrections
Rev. 1.11	2022-01-10	Corrected typo in equation 2 on page 12