

Automotive-grade high voltage ignition coil driver NPN power Darlington transistor

Datasheet - production data

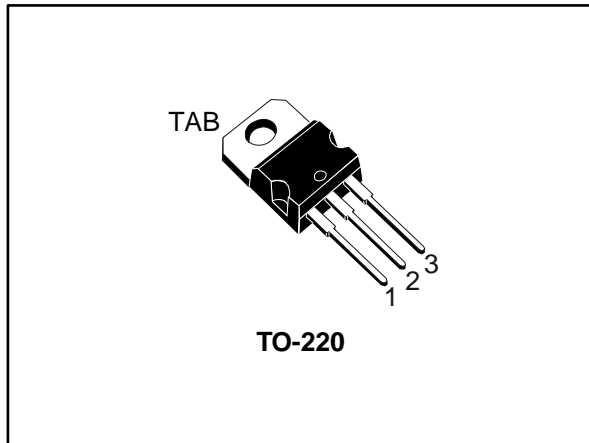

Figure 1: Internal schematic diagram

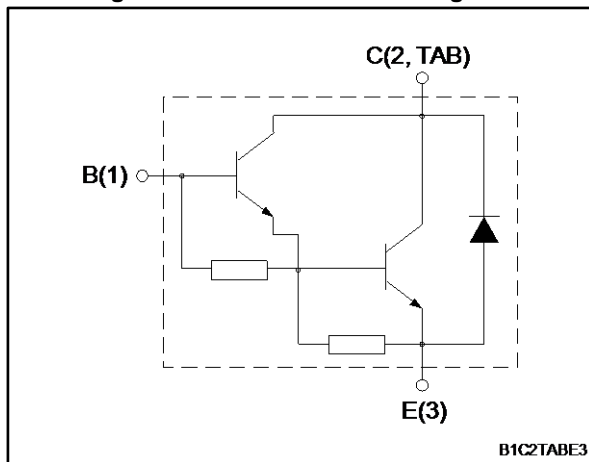

Table 1: Device summary

Order code	Marking	Package	Packing
BU931T	BU931T	TO-220	Tube

Features

- AEC-Q101 qualified
- Very rugged Bipolar technology
- High operating junction temperature



Applications

- High ruggedness electronic ignitions

Description

This is a high voltage power Darlington transistor developed using multi-epitaxial planar technology. It has been properly designed for automotive environment as electronic ignition power actuators.

Contents

1	Electrical ratings	3
2	Electrical characteristics	4
	2.1 Electrical characteristics (curves)	5
3	Test circuits	7
4	Package information	8
	4.1 TO-220 type A package information.....	9
5	Revision history	11

1 Electrical ratings

Table 2: Absolute maximum ratings

Symbol	Parameter	Value	Unit
V_{CES}	Collector-emitter voltage ($V_{BE} = 0$)	500	V
V_{CEO}	Collector-emitter voltage ($I_B = 0$)	400	V
V_{EBO}	Emitter-base voltage ($I_C = 0$)	5	V
I_C	Collector current	10	A
I_{CM}	Collector peak current	20	A
I_B	Base current	1	A
I_{BM}	Base peak current	5	A
P_{TOT}	Total dissipation at $T_C = 25\text{ °C}$	125	W
T_{stg}	Storage temperature range	-65 to 175	°C
T_j	Operating junction temperature range		°C

Table 3: Thermal data

Symbol	Parameter	Value	Unit
R_{thJC}	Thermal resistance junction-case	1.2	°C/W
R_{thJA}	Thermal resistance junction-ambient	62.5	°C/W

2 Electrical characteristics

($T_C = 25\text{ °C}$ unless otherwise specified)

Table 4: Electrical characteristics

Symbol	Parameter	Test conditions	Min.	Typ.	Max.	Unit
I_{CES}	Collector cut-off current	$V_{BE} = 0\text{ V}, V_{CE} = 500\text{ V}$		-	100	μA
		$V_{BE} = 0\text{ V}, V_{CE} = 500\text{ V}, T_C = 125\text{ °C}$ ⁽¹⁾		-	0.5	mA
I_{CEO}	Collector cut-off current	$I_B = 0\text{ A}, V_{CE} = 450\text{ V}$		-	100	μA
		$I_B = 0\text{ A}, V_{CE} = 450\text{ V}, T_C = 125\text{ °C}$ ⁽¹⁾		-	0.5	mA
I_{EBO}	Emitter cut-off current	$I_C = 0\text{ A}, V_{EB} = 5\text{ V}$		-	20	mA
$V_{CEO(sus)}$ ⁽²⁾	Collector-emitter sustaining voltage	$I_B = 0\text{ A}, I_C = 100\text{ mA}$	400	-		V
$V_{CE(sat)}$ ⁽²⁾	Collector-emitter saturation voltage	$I_C = 7\text{ A}, I_B = 70\text{ mA}$		-	1.6	V
		$I_C = 8\text{ A}, I_B = 100\text{ mA}$		-	1.8	V
		$I_C = 10\text{ A}, I_B = 250\text{ mA}$		-	1.8	V
$V_{BE(sat)}$ ⁽²⁾	Base-emitter saturation voltage	$I_C = 7\text{ A}, I_B = 70\text{ mA}$		-	2.2	V
		$I_C = 8\text{ A}, I_B = 100\text{ mA}$		-	2.4	V
		$I_C = 10\text{ A}, I_B = 250\text{ mA}$		-	2.5	V
h_{FE} ⁽²⁾	DC current gain	$I_C = 5\text{ A}, V_{CE} = 10\text{ V}$	300	-		
V_F	Diode forward voltage	$I_F = 10\text{ A}$		-	2.5	V
	Functional test	$V_{CC} = 24\text{ V}, L = 7\text{ mH}, V_{clamp} = 400\text{ V}$ (see Figure 10: "Functional test circuit")	8	-		A

Notes:

⁽¹⁾Defined by design, not subject to production test.

⁽²⁾Pulse test: pulse duration $\leq 300\text{ }\mu\text{s}$, duty cycle $\leq 2\%$.

Table 5: Inductive load switching times

Symbol	Parameter	Test conditions	Min.	Typ.	Max.	Unit
t_s	Storage time	$V_{CC} = 12\text{ V}, V_{clamp} = 300\text{ V}, L = 7\text{ mH}, R_{BE} = 47\text{ }\Omega, I_C = 7\text{ A}, I_B = 70\text{ mA}$	-	15	-	μs
t_f	Fall time		-	0.5	-	μs

2.1 Electrical characteristics (curves)

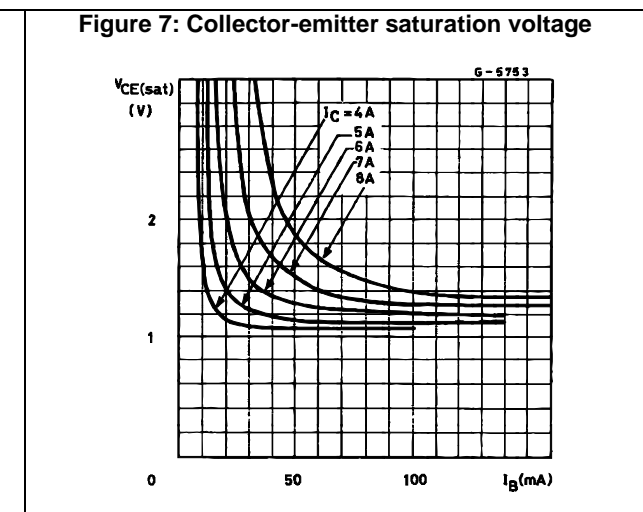
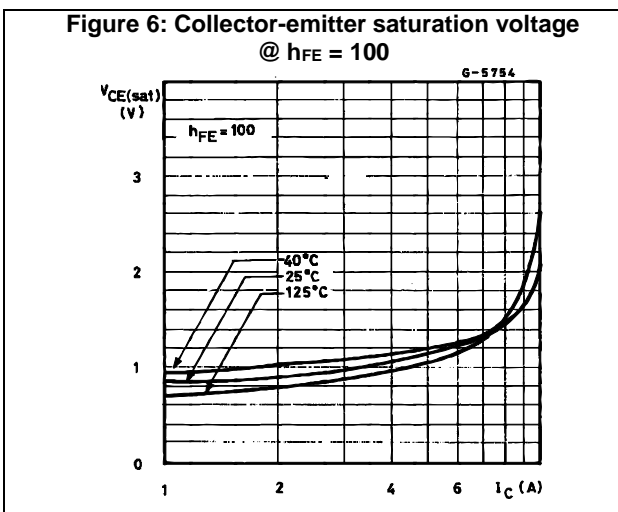
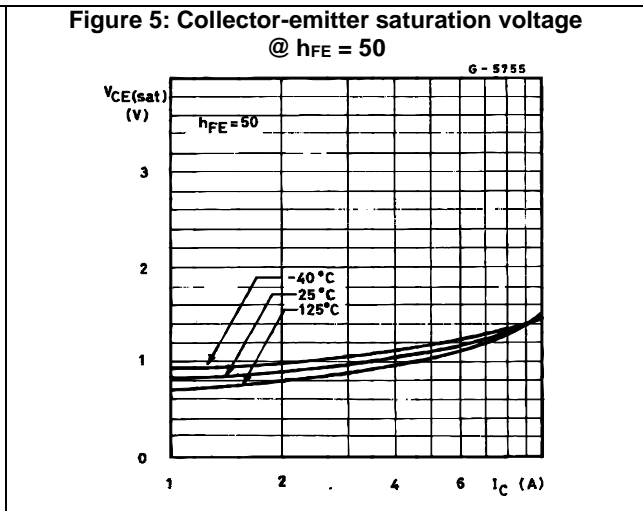
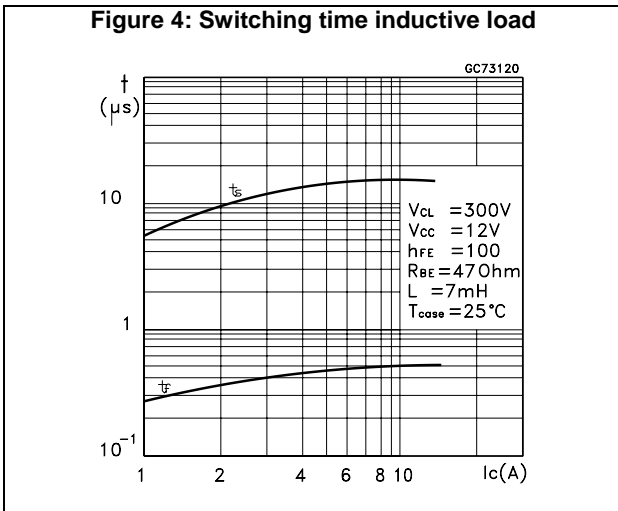
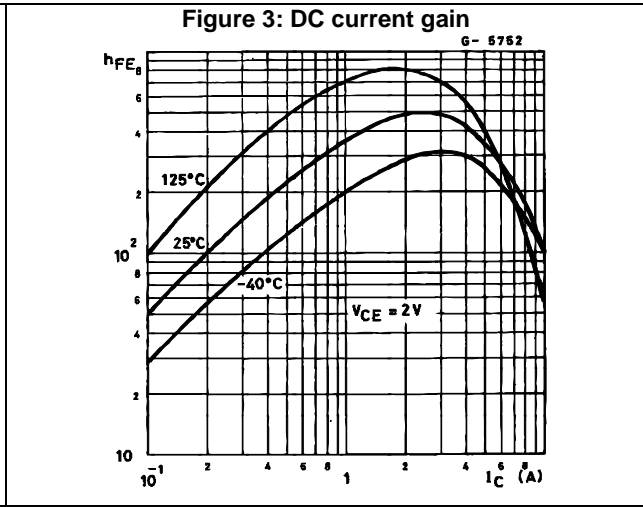
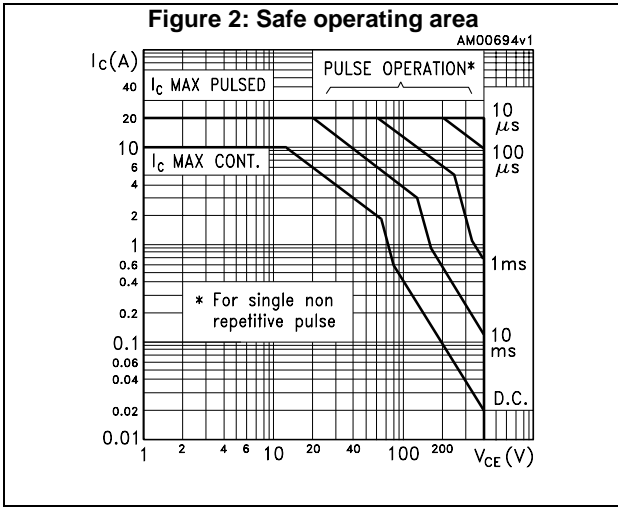

Figure 8: Base-emitter saturation voltage @ $h_{FE} = 50$

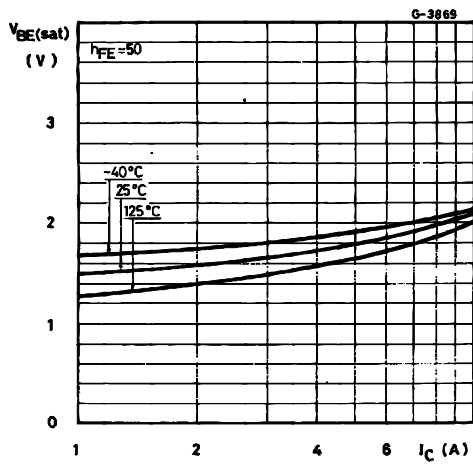
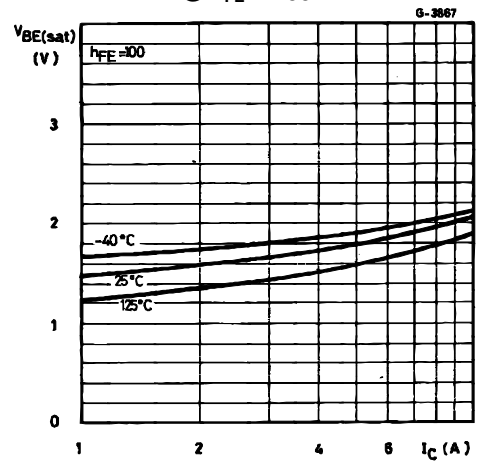

Figure 9: Base-emitter saturation voltage @ $h_{FE} = 100$



3 Test circuits

Figure 10: Functional test circuit

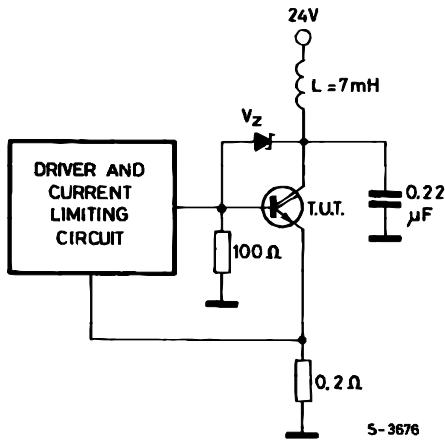

Figure 11: Functional test waveforms

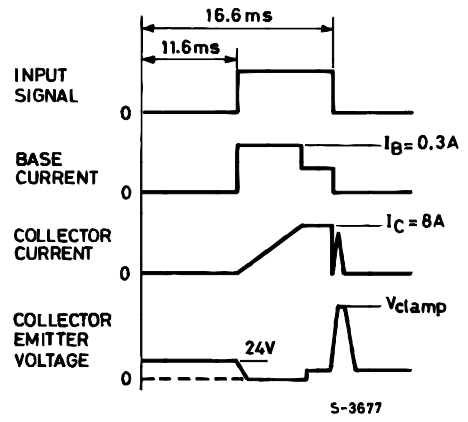

Figure 12: Switching time test circuit

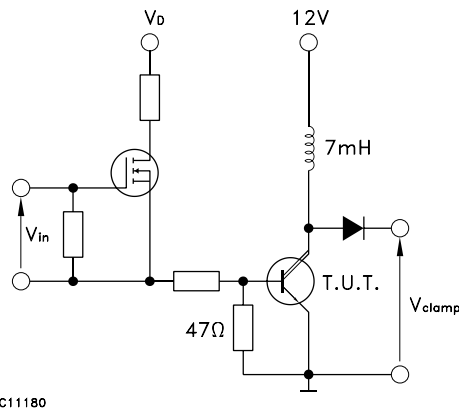
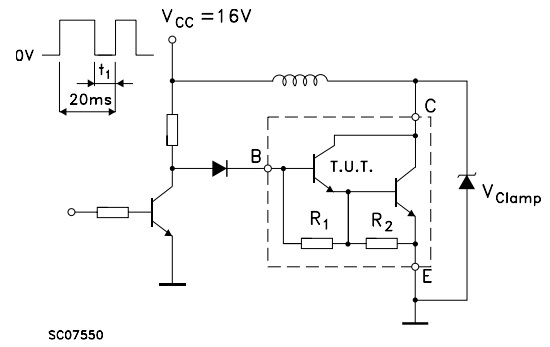

Figure 13: Sustaining voltage test circuit



4 Package information

In order to meet environmental requirements, ST offers these devices in different grades of ECOPACK® packages, depending on their level of environmental compliance. ECOPACK® specifications, grade definitions and product status are available at: www.st.com. ECOPACK® is an ST trademark.

4.1 TO-220 type A package information

Figure 14: TO-220 type A package outline

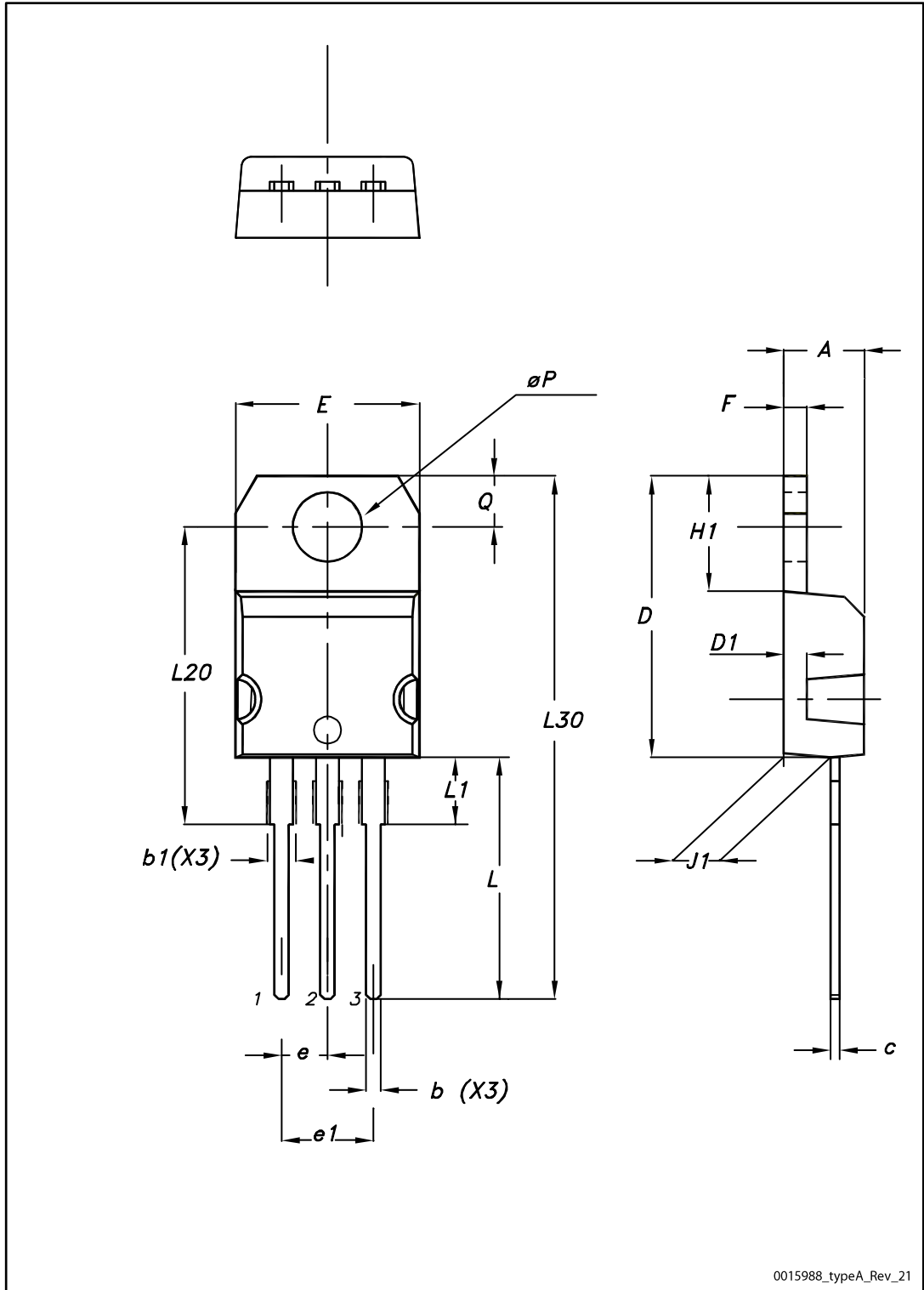

Table 6: TO-220 type A package mechanical data

Dim.	mm		
	Min.	Typ.	Max.
A	4.40		4.60
b	0.61		0.88
b1	1.14		1.55
c	0.48		0.70
D	15.25		15.75
D1		1.27	
E	10.00		10.40
e	2.40		2.70
e1	4.95		5.15
F	1.23		1.32
H1	6.20		6.60
J1	2.40		2.72
L	13.00		14.00
L1	3.50		3.93
L20		16.40	
L30		28.90	
øP	3.75		3.85
Q	2.65		2.95

5 Revision history

Table 7: Document revision history

Date	Revision	Changes
18-Nov-2008	3	Package changed from TO-218 to TO-247 for BU931P. Inserted type in TO-220 (BU931T).
02-Dec-2009	4	Modified I _c test condition value of V _{CEO(sus)} parameter <i>Table 4 on page 4</i> , updated TO-220 package mechanical data.
12-Oct-2017	5	The part numbers BU931 and BU931P have been moved to two separate datasheets. Modified <i>Table 2: "Absolute maximum ratings"</i> , <i>Table 3: "Thermal data"</i> and <i>Table 4: "Electrical characteristics"</i> . Updated <i>Section 4: "Package information"</i> . Minor text changes.