

Features

- Low spread of dynamic parameters
- High voltage capability
- Minimum lot-to-lot spread for reliable operation
- Very high switching speed

Applications

- Electronic ballast for fluorescent lighting
- Switch mode power supplies

Description

The devices are manufactured using high voltage multi-epitaxial planar technology for high switching speeds and high voltage capability. Thanks to an increased intermediate layer, it has an intrinsic ruggedness which enables the transistor to withstand an high collector current level during breakdown condition, without using the transil protection usually necessary in typical converters for lamp ballast.

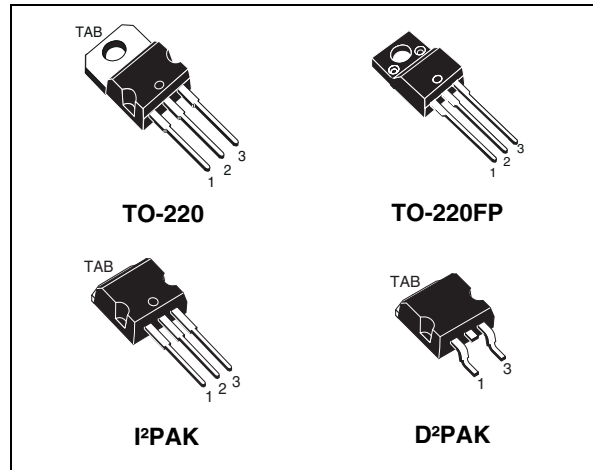

Figure 1. Internal schematic diagram

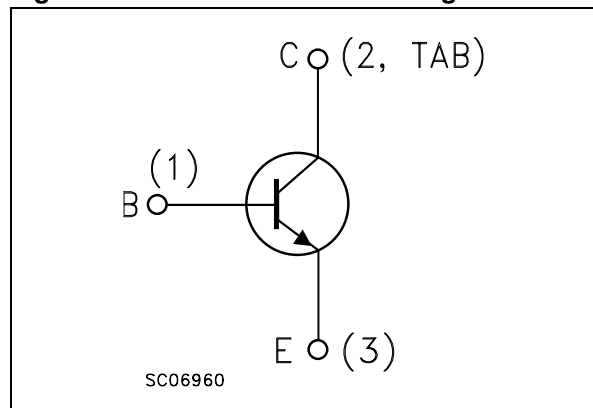

Table 1. Device summary

Order codes	Markings	Packages	Packaging
BUL742C	BUL742C	TO-220	Tube
BUL742CFP	BUL742CFP	TO-220FP	
BULB742C-1	BULB742C	I ² PAK	
BULB742CT4	BULB742C	D ² PAK	Tape and reel

1 Electrical ratings

Table 2. Absolute maximum ratings

Symbol	Parameter	TO-220 / D ² PAK / I ² PAK	TO-220FP	Unit
V _{CES}	Collector-emitter voltage (V _{BE} = 0)	1050		V
V _{CEO}	Collector-emitter voltage (I _B = 0)	400		V
V _{EBO}	Emitter-base voltage (I _C = 0, I _B = 2 A, t _p < 10 ms)	V _{(BR)EBO}		V
I _C	Collector current	4		A
I _{CM}	Collector peak current (t _p < 5 ms)	8		A
I _B	Base current	2		A
I _{BM}	Base peak current (t _p < 5 ms)	4		A
P _{TOT}	Total dissipation at T _c = 25 °C	70	30	W
T _{STG}	Storage temperature	-65 to 150		°C
V _{ISO}	Isolation withstand voltage (RMS) from all three leads to external heatsink	1500		V
T _J	Max. operating junction temperature	150		°C

Table 3. Thermal data

Symbol	Parameter	TO-220/D ² PAK/I ² PAK	TO-220FP	Unit
R _{thJC}	Thermal resistance junction - case	1.79	4.17	°C/W
R _{thJA}	Thermal resistance junction - ambient	62.5	62.5	°C/W

2 Electrical characteristics

$T_{\text{case}} = 25^{\circ}\text{C}$ unless otherwise specified.

Table 4. Electrical characteristics

Symbol	Parameter	Test conditions	Min.	Typ.	Max.	Unit
I_{CES}	Collector cut-off current ($V_{\text{BE}} = 0$)	$V_{\text{CE}} = 1050 \text{ V}$		0.2	10	μA
I_{CEO}	Collector cut-off current ($I_{\text{B}} = 0$)	$V_{\text{CE}} = 400 \text{ V}$		10	250	μA
$V_{(\text{BR})\text{EBO}}$	Emitter base breakdown voltage ($I_{\text{C}} = 0$)	$I_{\text{E}} = 1 \text{ mA}$	15	19	24	V
$V_{\text{CEO(sus)}}^{(1)}$	Collector-emitter sustaining voltage ($I_{\text{B}} = 0$)	$I_{\text{C}} = 10 \text{ mA}$	400	450		V
$V_{\text{CE(sat)}}^{(1)}$	Collector-emitter saturation voltage	$I_{\text{C}} = 1 \text{ A}$ $I_{\text{B}} = 0.2 \text{ A}$ $I_{\text{C}} = 3.5 \text{ A}$ $I_{\text{B}} = 1 \text{ A}$		0.15 0.6	0.5 1.5	V V
$V_{\text{BE(sat)}}^{(1)}$	Base-emitter saturation voltage	$I_{\text{C}} = 3.5 \text{ A}$ $I_{\text{B}} = 1 \text{ A}$		1.1	1.5	V
$h_{\text{FE}}^{(1)}$	DC current gain	$I_{\text{C}} = 0.1 \text{ A}$ $V_{\text{CE}} = 5 \text{ V}$ $I_{\text{C}} = 0.8 \text{ A}$ $V_{\text{CE}} = 3 \text{ V}$	48 25	75 35	100 50	
t_{s} t_{f}	Resistive load Storage time Fall time	$I_{\text{C}} = 2 \text{ A}$ $V_{\text{CC}} = 125 \text{ V}$ $I_{\text{B1}} = - I_{\text{B2}} = 400 \text{ mA}$ $t_{\text{p}} = 300 \mu\text{s}$ $V_{\text{BE(off)}} = -5 \text{ V}$		2.4 350	3.5 500	μs ns
E_{ar}	Repetitive avalanche energy	$L = 2 \text{ mH}$ $C = 1.8 \text{ nF}$ $V_{\text{BE(off)}} = -5 \text{ V}$	6			mJ

1. Pulse test: pulse duration $\leq 300 \mu\text{s}$, duty cycle $\leq 2\%$.

2.1 Electrical characteristics (curves)

Figure 2. Safe operating area for TO-220/I²PAK/D²PAK

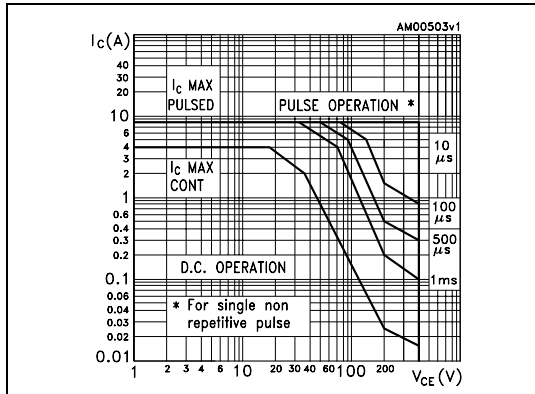

Figure 3. Safe operating area for TO-220FP

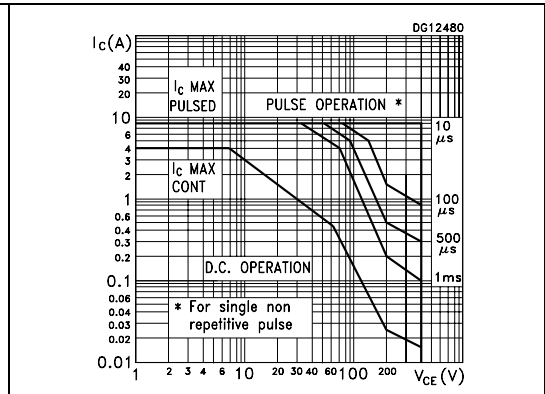

Figure 4. Derating curve

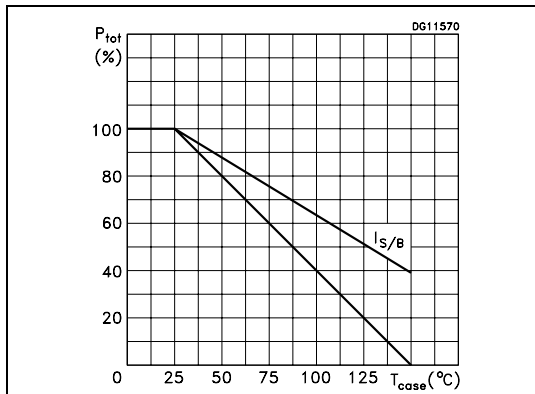

Figure 5. Output characteristics

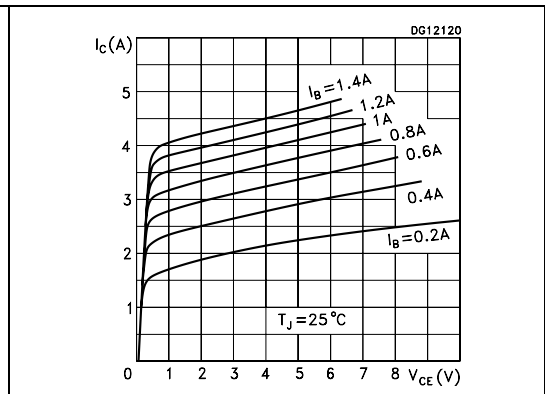

Figure 6. DC current gain ($V_{CE} = 3\text{ V}$)

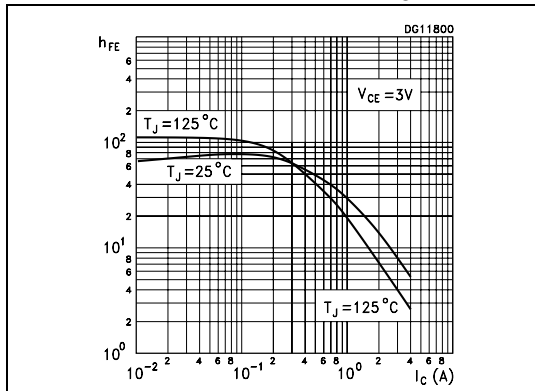

Figure 7. DC current gain ($V_{CE} = 5\text{ V}$)

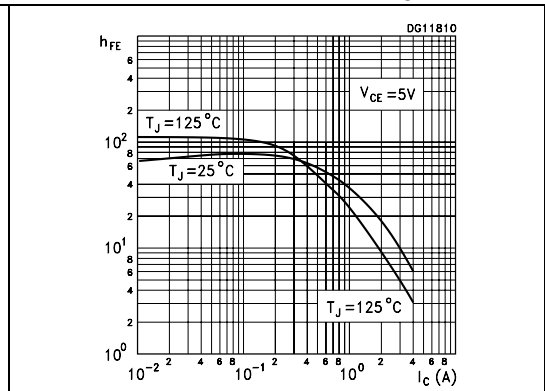

Figure 8. Collector - emitter saturation voltage Figure 9. Base-emitter saturation voltage

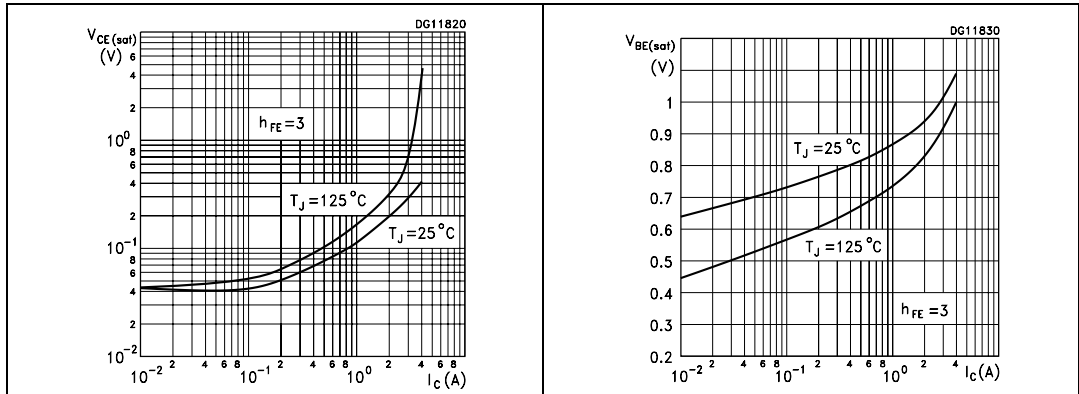

Figure 10. Resistive load switching on times ($h_{FE} = 5$) Figure 11. Resistive load switching off times ($h_{FE} = 5$)

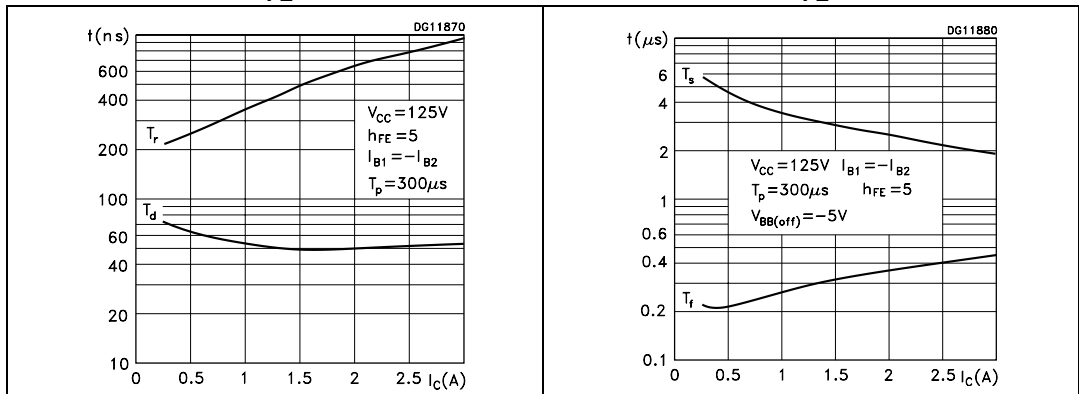

Figure 12. Resistive load switching on times ($h_{FE} = 10$) Figure 13. Resistive load switching off times ($h_{FE} = 10$)

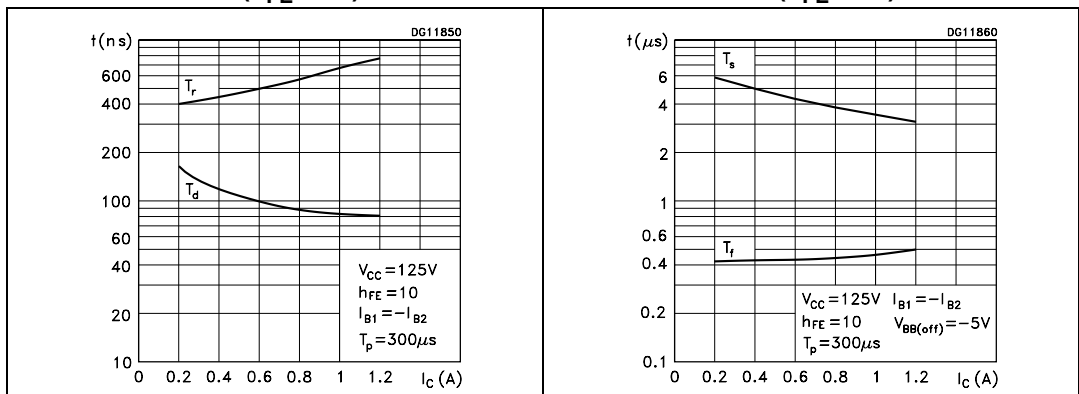
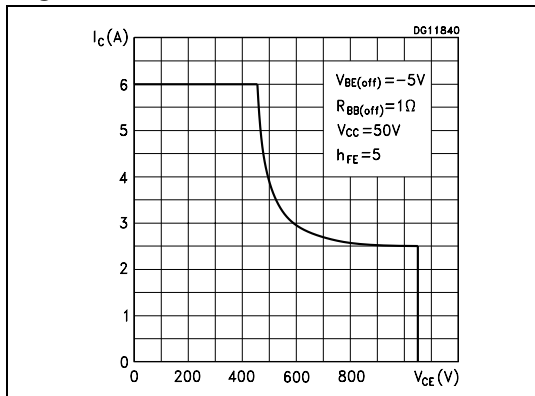

Figure 14. Reverse biased SOA



3 Test circuit

Figure 15. Energy rating test circuit

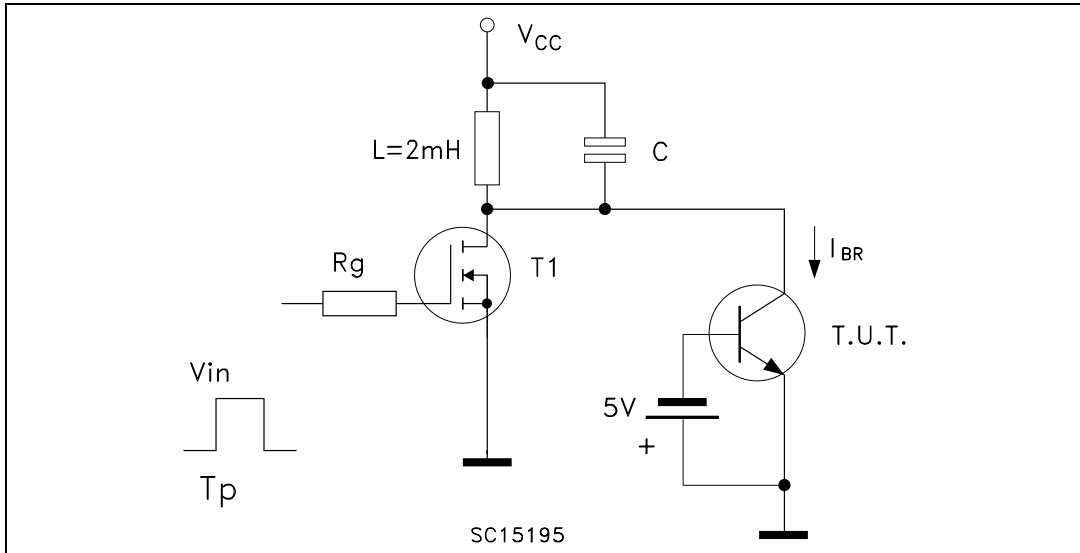
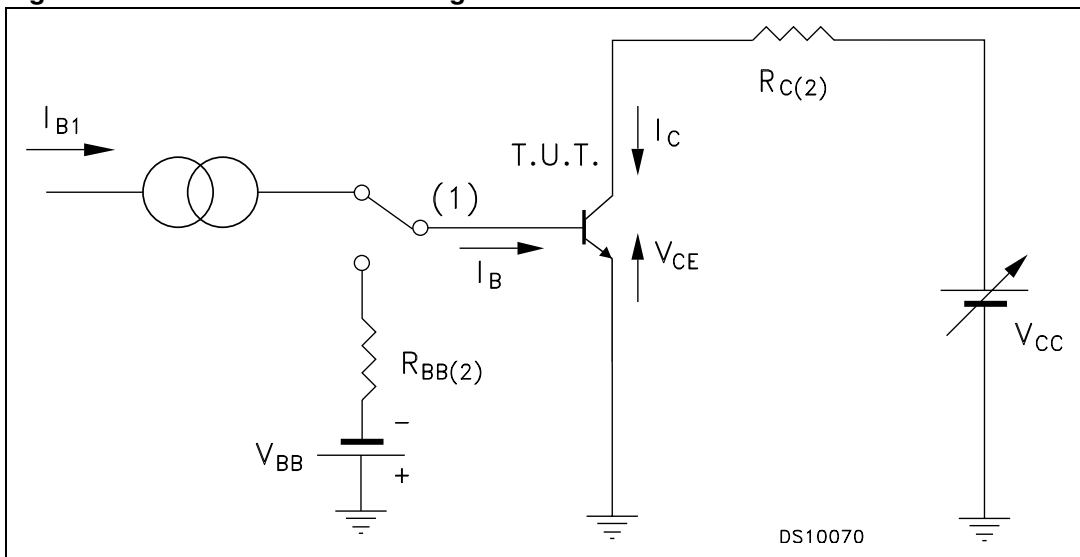

Figure 16. Resistive load switching test circuit



4 Package mechanical data

In order to meet environmental requirements, ST offers these devices in different grades of ECOPACK[®] packages, depending on their level of environmental compliance. ECOPACK[®] specifications, grade definitions and product status are available at: www.st.com. ECOPACK[®] is an ST trademark.

TO-220 type A mechanical data

Dim	mm		
	Min	Typ	Max
A	4.40		4.60
b	0.61		0.88
b1	1.14		1.70
c	0.48		0.70
D	15.25		15.75
D1		1.27	
E	10		10.40
e	2.40		2.70
e1	4.95		5.15
F	1.23		1.32
H1	6.20		6.60
J1	2.40		2.72
L	13		14
L1	3.50		3.93
L20		16.40	
L30		28.90	
∅P	3.75		3.85
Q	2.65		2.95

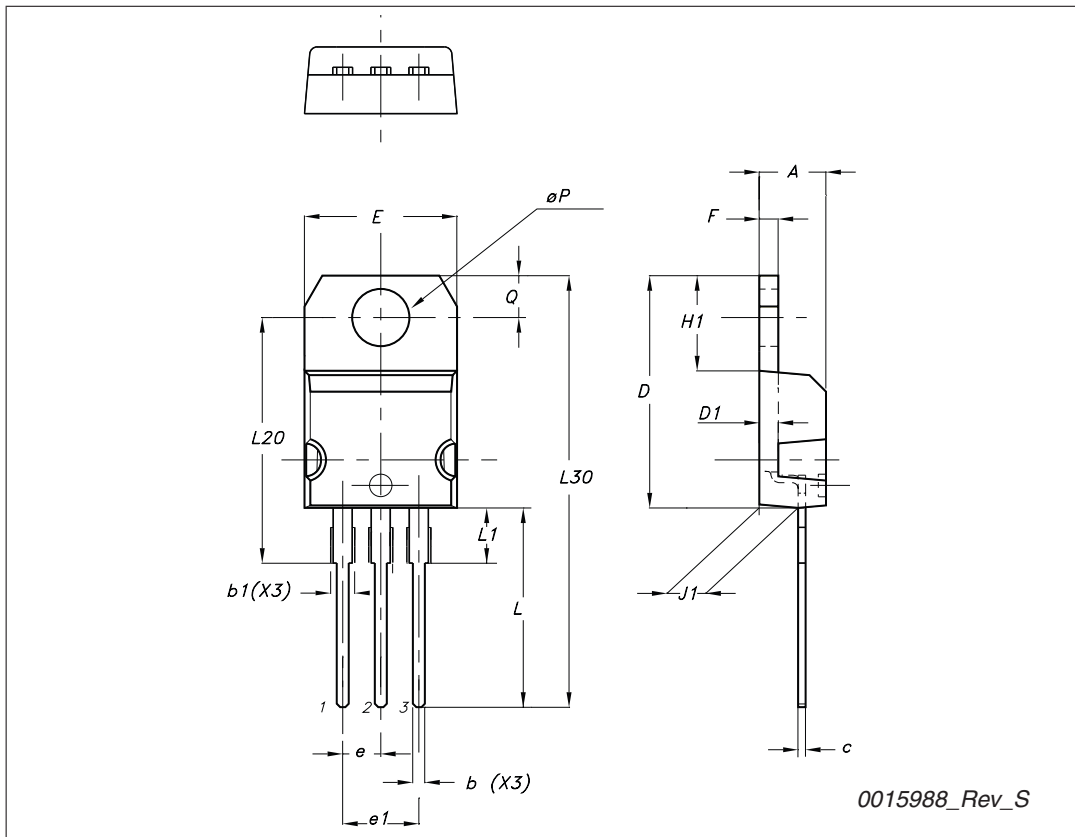

I²PAK (TO-262) mechanical data

Dim	mm			inch		
	Min	Typ	Max	Min	Typ	Max
A	4.40		4.60	0.173		0.181
A1	2.40		2.72	0.094		0.107
b	0.61		0.88	0.024		0.034
b1	1.14		1.70	0.044		0.066
c	0.49		0.70	0.019		0.027
c2	1.23		1.32	0.048		0.052
D	8.95		9.35	0.352		0.368
e	2.40		2.70	0.094		0.106
e1	4.95		5.15	0.194		0.202
E	10		10.40	0.393		0.410
L	13		14	0.511		0.551
L1	3.50		3.93	0.137		0.154
L2	1.27		1.40	0.050		0.055

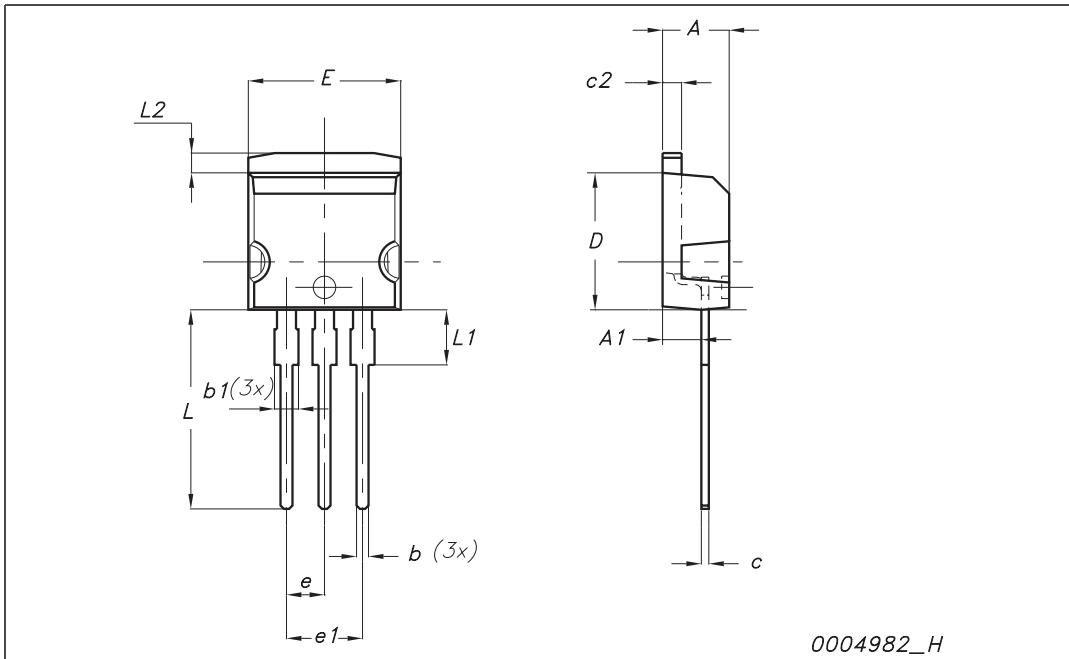
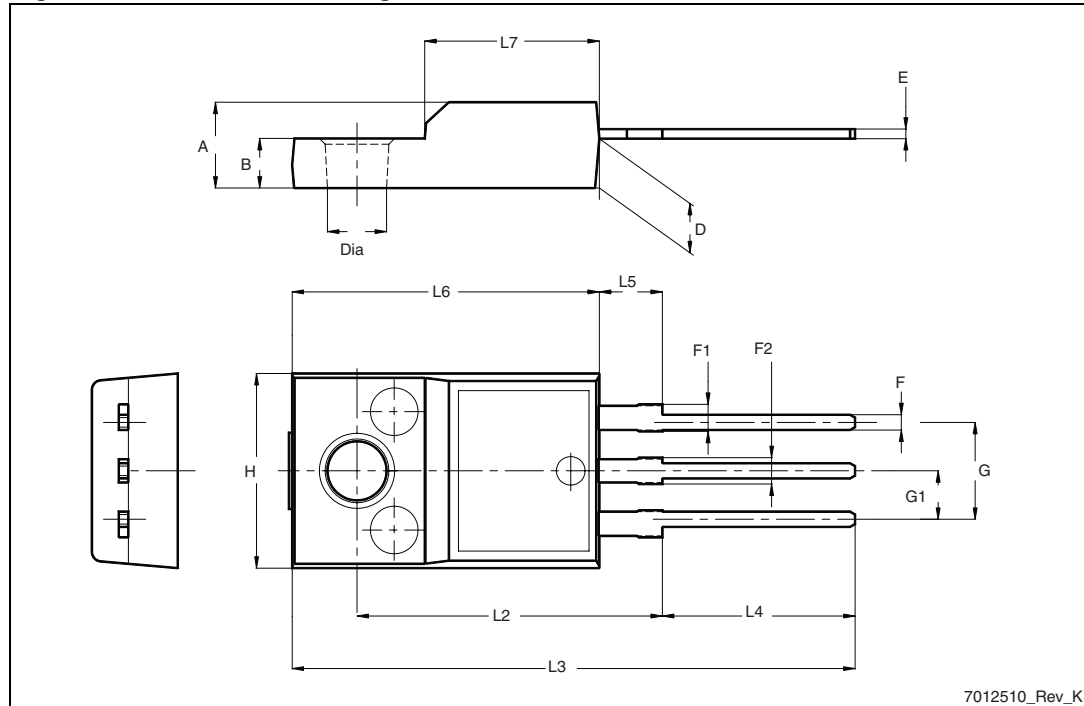

Table 5. TO-220FP mechanical data

Dim.	mm.		
	Min.	Typ.	Max.
A	4.4		4.6
B	2.5		2.7
D	2.5		2.75
E	0.45		0.7
F	0.75		1
F1	1.15		1.70
F2	1.15		1.70
G	4.95		5.2
G1	2.4		2.7
H	10		10.4
L2		16	
L3	28.6		30.6
L4	9.8		10.6
L5	2.9		3.6
L6	15.9		16.4
L7	9		9.3
Dia	3		3.2

Figure 17. TO-220FP drawing



D²PAK (TO-263) mechanical data

Dim.	mm.		
	Min.	Typ.	Max.
A	4.40		4.60
A1	0.03		0.23
b	0.70		0.93
b2	1.14		1.70
c	0.45		0.60
c2	1.23		1.36
D	8.95		9.35
D1	7.50		
E	10		10.40
E1	8.50		
e		2.54	
e1	4.88		5.28
H	15		15.85
J1	2.49		2.69
L	2.29		2.79
L1	1.27		1.40
L2	1.30		1.75
R		0.4	
V2	0°		8°

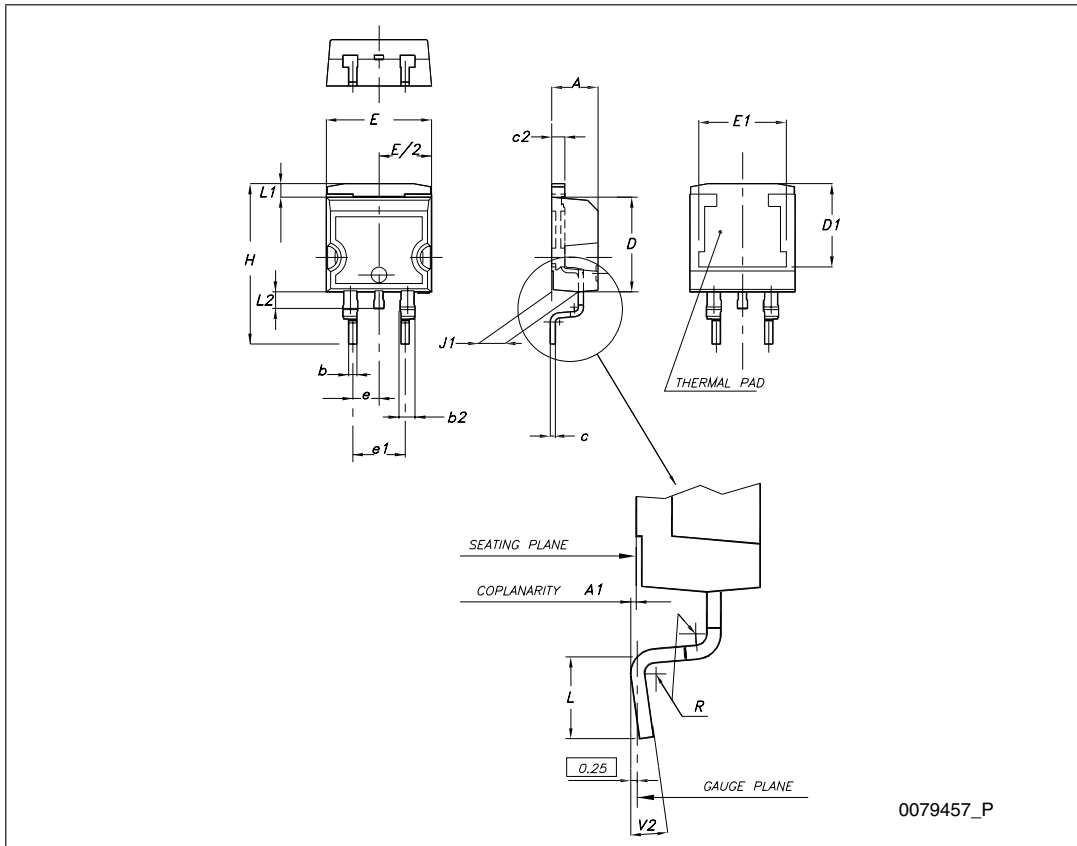

5 Revision history

Table 6. Document revision history

Date	Revision	Changes
21-Jun-2004	1	First release
10-Aug-2007	2	No content changes, document reformatted
27-May-2008	3	Added I ² PAK package
30-Nov-2010	4	Added TO-220FP and D ² PAK packages