

Features

- Low spread of dynamic parameters
- High voltage capability
- Minimum lot-to-lot spread for reliable operation
- Very high switching speed

Applications

- Electronic ballast for fluorescent lighting up to 256 W (8 x 32 W)
- Switch mode power supplies

Description

The device is manufactured using the diffused collector in planar technology adopting new and enhanced high voltage structure. It has an intrinsic ruggedness which enables the transistor to withstand an high collector current level during breakdown condition, without using the transil protection usually necessary in typical converters for lamp ballast.

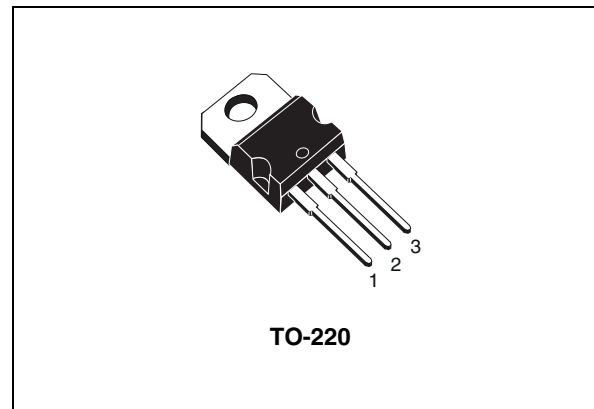

Figure 1. Internal schematic diagram

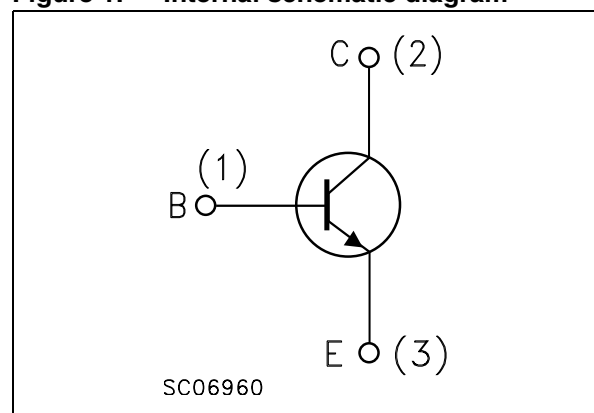

Table 1. Device summary

Order code	Marking	Package	Packaging
BUL743	BUL743	TO-220	Tube

1 Electrical ratings

Table 2. Absolute maximum ratings

Symbol	Parameter	Value	Unit
V_{CES}	Collector-emitter voltage ($V_{BE} = 0$)	1200	V
V_{CEO}	Collector-emitter voltage ($I_B = 0$)	500	V
V_{EBO}	Emitter-base voltage ($I_C = 0$, $I_B = 6$ A, $t_p < 10$ ms)	$V_{(BR)EBO}$	V
I_C	Collector current	12	A
I_{CM}	Collector peak current ($t_p < 5$ ms)	24	A
I_B	Base current	6	A
I_{BM}	Base peak current ($t_p < 5$ ms)	12	A
P_{tot}	Total dissipation at $T_C = 25$ °C	100	W
T_{stg}	Storage temperature	-65 to 150	°C
T_J	Max. operating junction temperature	150	°C

Table 3. Thermal data

Symbol	Parameter	Value	Unit
$R_{thj-case}$	Thermal resistance junction - case	1.25	°C/W
$R_{thj-amb}$	Thermal resistance junction - ambient	62.5	°C/W

2 Electrical characteristics

($T_{\text{case}} = 25\text{ °C}$ unless otherwise specified)

Table 4. Electrical characteristics

Symbol	Parameter	Test conditions	Min.	Typ.	Max.	Unit
I_{CES}	Collector cut-off current ($V_{\text{BE}} = 0$)	$V_{\text{CE}} = 1200\text{ V}$		0.2	10	μA
I_{CEO}	Collector cut-off current ($I_{\text{B}} = 0$)	$V_{\text{CE}} = 500\text{ V}$		10	250	μA
$V_{(\text{BR})\text{EBO}}$	Emitter base breakdown voltage ($I_{\text{C}} = 0$)	$I_{\text{E}} = 1\text{ mA}$	15	19	24	V
$V_{\text{CEO(sus)}}^{(1)}$	Collector-emitter sustaining voltage ($I_{\text{B}} = 0$)	$I_{\text{C}} = 50\text{ mA}$	500			V
$V_{\text{CE(sat)}}^{(1)}$	Collector-emitter saturation voltage	$I_{\text{C}} = 3\text{ A}$ $I_{\text{B}} = 0.6\text{ A}$ $I_{\text{C}} = 10\text{ A}$ $I_{\text{B}} = 2.5\text{ A}$		0.15 0.6	0.5 1.5	V V
$V_{\text{BE(sat)}}^{(1)}$	Base-emitter saturation voltage	$I_{\text{C}} = 10\text{ A}$ $I_{\text{B}} = 2.5\text{ A}$		1.1	1.5	V
$h_{\text{FE}}^{(1)}$	DC current gain	$I_{\text{C}} = 0.5\text{ A}$ $V_{\text{CE}} = 5\text{ V}$ $I_{\text{C}} = 2\text{ A}$ $V_{\text{CE}} = 3\text{ V}$	35 24	55 34	80 45	
t_{s} t_{f}	Resistive load Storage time Fall time	$I_{\text{C}} = 6\text{ A}$ $V_{\text{CC}} = 125\text{ V}$ $I_{\text{B(on)}} = -I_{\text{B(off)}} = 1.2\text{ A}$ $t_{\text{p}} = 300\text{ }\mu\text{s}$ $V_{\text{BE(off)}} = -5\text{ V}$		2.5 400	3.8 500	μs ns
E_{ar}	Repetitive avalanche energy	$L = 2\text{ mH}$ $C = 1.8\text{ nF}$ $V_{\text{BE(off)}} = -5\text{ V}$	3			mJ

1. Pulsed duration = 300 μs , duty cycle $\leq 1.5\%$

2.1 Electrical characteristics (curves)

Figure 2. Safe operating area

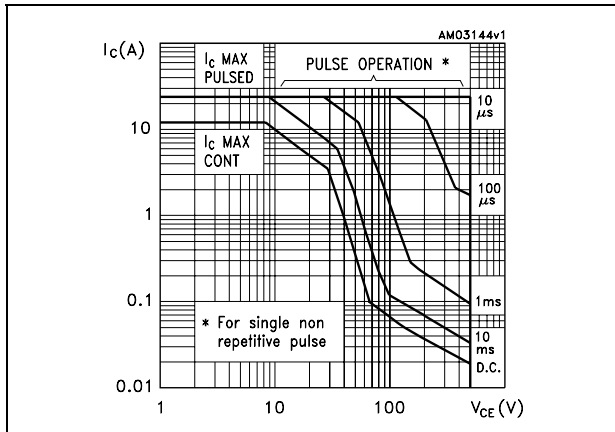

Figure 3. Derating curve

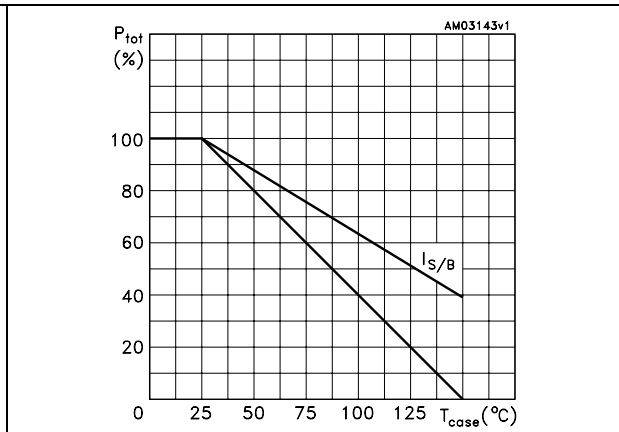

Figure 4. DC current gain ($V_{CE} = 3 V$)

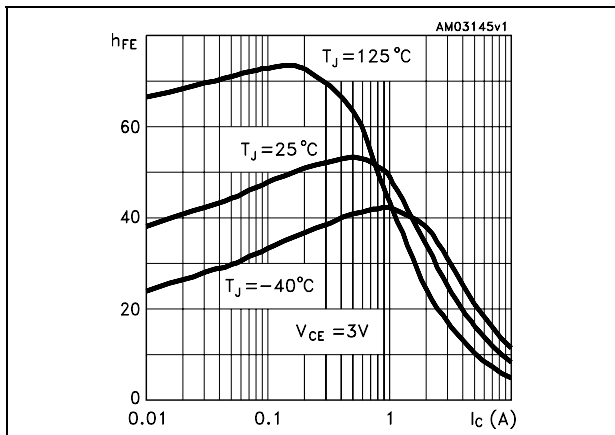

Figure 5. DC current gain ($V_{CE} = 5 V$)

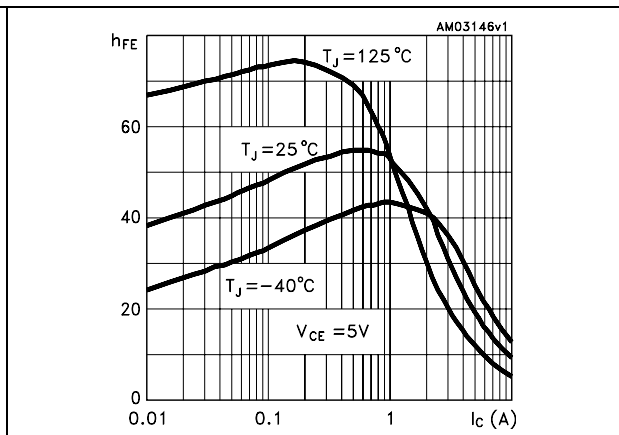

Figure 6. Collector-emitter saturation voltage

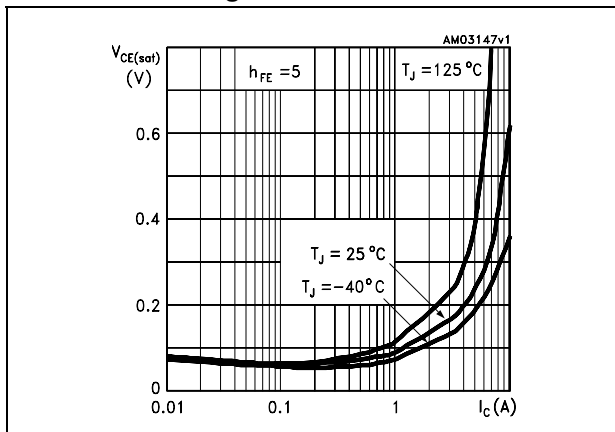

Figure 7. Base-emitter saturation voltage

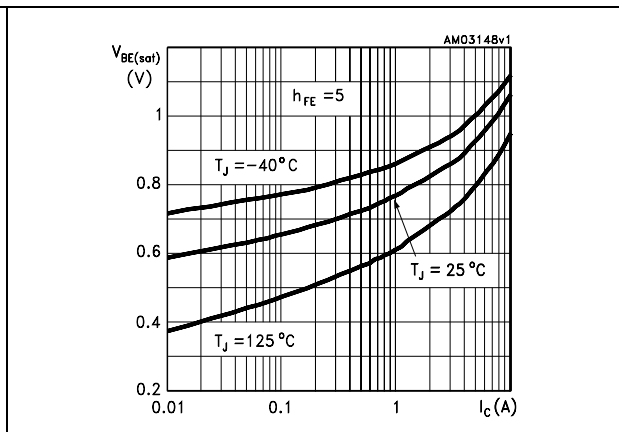

Figure 8. Output characteristics

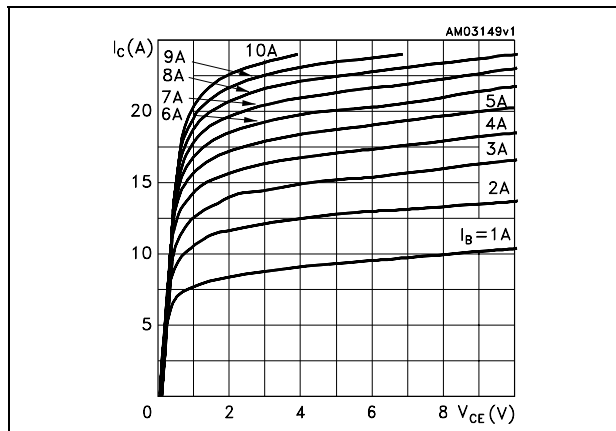

Figure 9. Reverse biased safe operating area

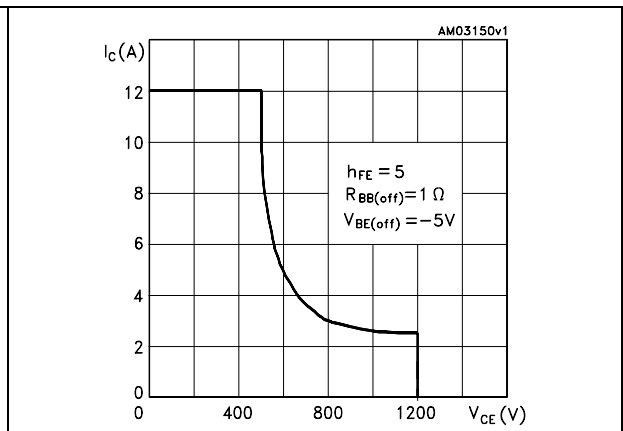

Figure 10. Resistive load switching time (on)

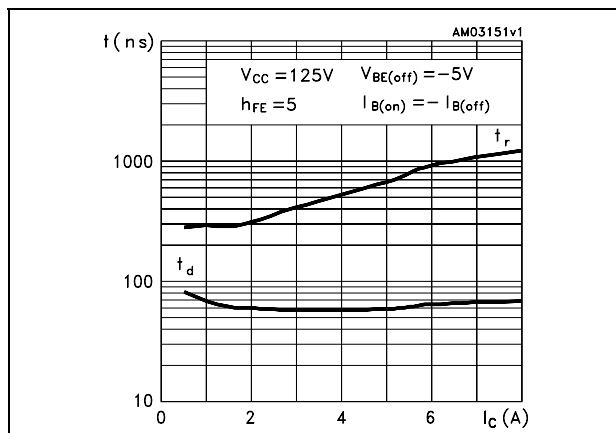
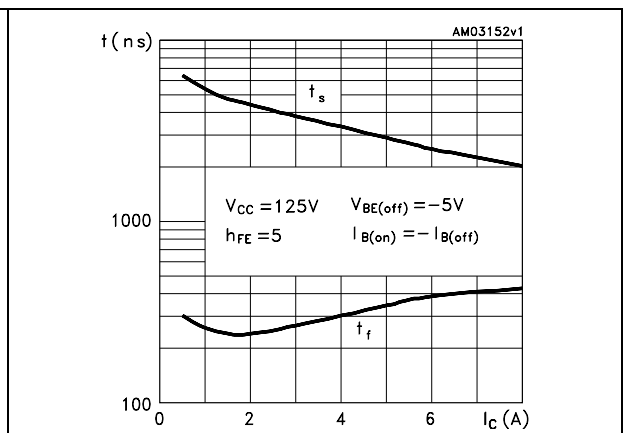

Figure 11. Resistive load switching time (off)



2.2 Test circuits

Figure 12. Energy rating test circuit

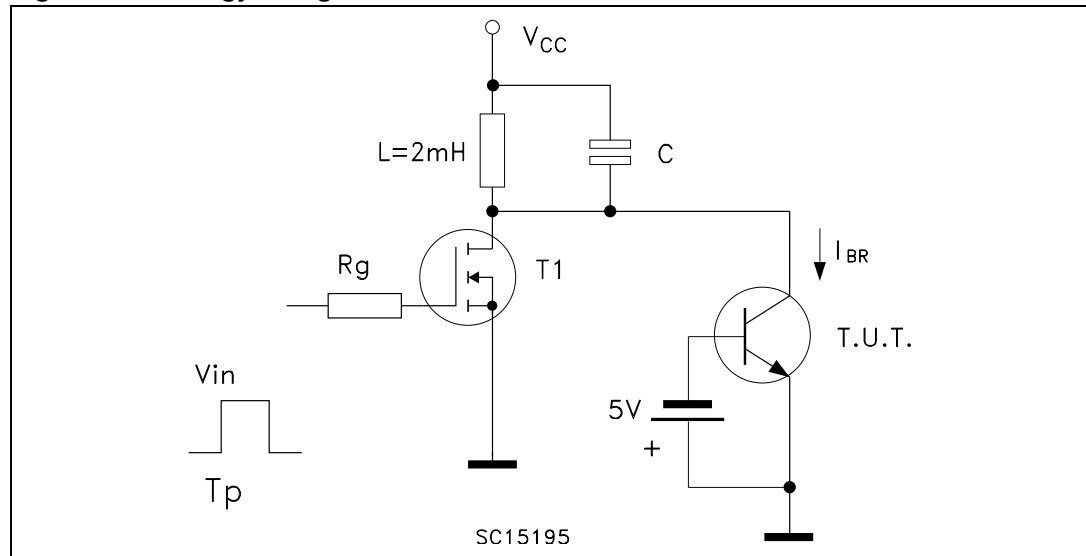
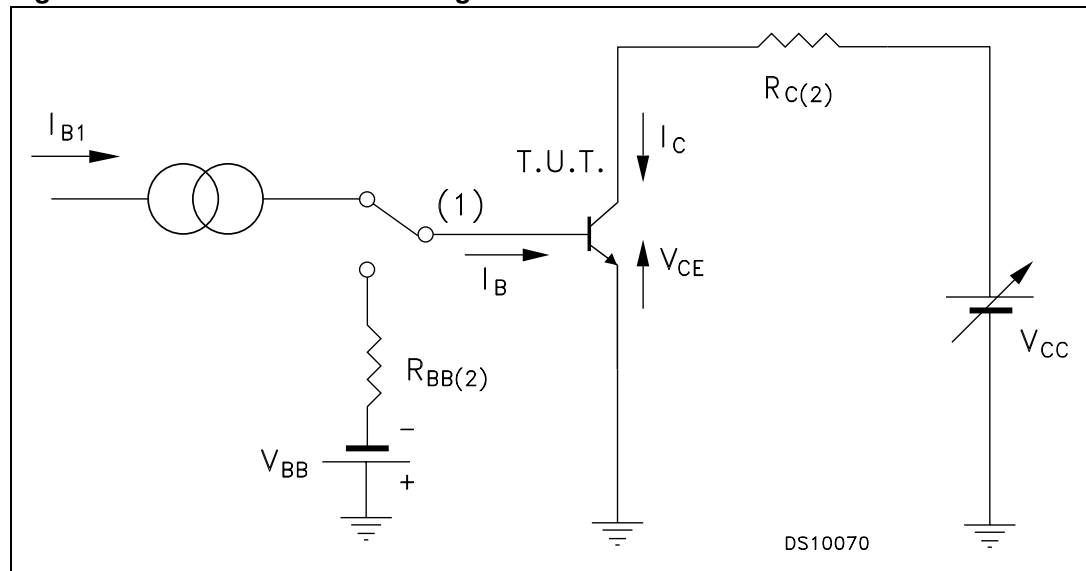

Figure 13. Resistive load switching test circuit



1. Fast electronic switch
2. Non-inductive resistor

3 Package mechanical data

In order to meet environmental requirements, ST offers these devices in different grades of ECOPACK[®] packages, depending on their level of environmental compliance. ECOPACK[®] specifications, grade definitions and product status are available at: www.st.com. ECOPACK[®] is an ST trademark.

TO-220 mechanical data

Dim	mm			inch		
	Min	Typ	Max	Min	Typ	Max
A	4.40		4.60	0.173		0.181
b	0.61		0.88	0.024		0.034
b1	1.14		1.70	0.044		0.066
c	0.48		0.70	0.019		0.027
D	15.25		15.75	0.6		0.62
D1		1.27			0.050	
E	10		10.40	0.393		0.409
e	2.40		2.70	0.094		0.106
e1	4.95		5.15	0.194		0.202
F	1.23		1.32	0.048		0.051
H1	6.20		6.60	0.244		0.256
J1	2.40		2.72	0.094		0.107
L	13		14	0.511		0.551
L1	3.50		3.93	0.137		0.154
L20		16.40			0.645	
L30		28.90			1.137	
∅P	3.75		3.85	0.147		0.151
Q	2.65		2.95	0.104		0.116

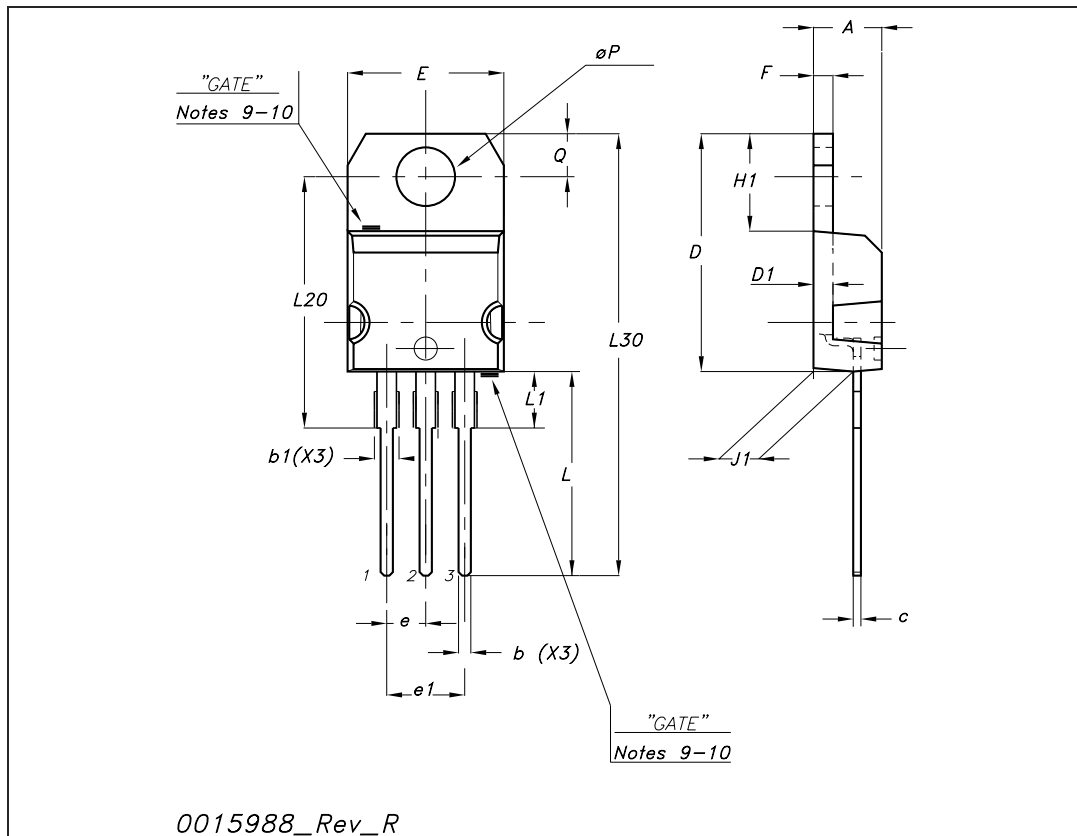

4 Revision history

Table 5. Document revision history

Date	Revision	Changes
09-Dec-2008	1	First release
20-Mar-2009	2	Added Section 2.1 <i>Section 2.1: Electrical characteristics (curves) on page 4</i>
25-May-2009	3	Document status promoted from preliminary data to datasheet