

## Current Transformer Features

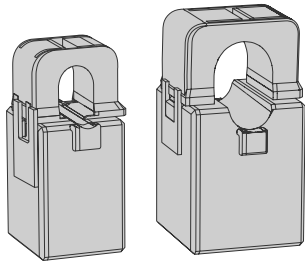

Split-core current transformers are used to monitor AC current for various devices. The current transformer input takes a high-voltage current input and produces a proportional low-voltage, low-current signal for measuring and monitoring. Split-core current transformers are ideal for installing onto existing electrical wiring because they can snap around the individual conductors without disconnecting any cables.

These split-core current transformers are compatible with Banner's Condition Monitoring devices (CM1L or Q45CT Nodes, and the S15C-CT-MQ Converters).

## Current Transformer Models

Model Kits	Description	Connection
BWA-CURRENT-TRANSFORMER-20A	Includes CT20A; 20 A Input; 0.333 V Output	1-meter two-wire twisted pair cable
BWA-CURRENT-TRANSFORMER-150A	Includes CT150A; 150 A Input; 0.333 V Output	
BWA-CURRENT-TRANSFORMER-600A	Includes CT600A; 600 A Input; 0.333 V Output	

## Installing the Current Transformers

Observe the polarity when installing current transformers. Banner's current transformers indicate **k (S1)** as the source side and **l (S2)** as the load side, where source refers to the incoming power feed side to the device and the load side is the device side.

Banner's CTs have an etched arrow to indicate the directionality for installation (k (S1) -> l (S2)). As shown in ["Installing a current transformer relative to the power supply/motor" on page 1](#), the source is the AC power supply and the load is the Motor. The CT direction arrow must point toward the load. Banner's current transformers can be installed on any conductor in a 2- or 3-phase AC line. Current transformers should only be installed on a single conductor. For the correct installation, see ["Installing a single conductor on the current transformer" on page 2](#).

*Installing a current transformer relative to the power supply/motor*

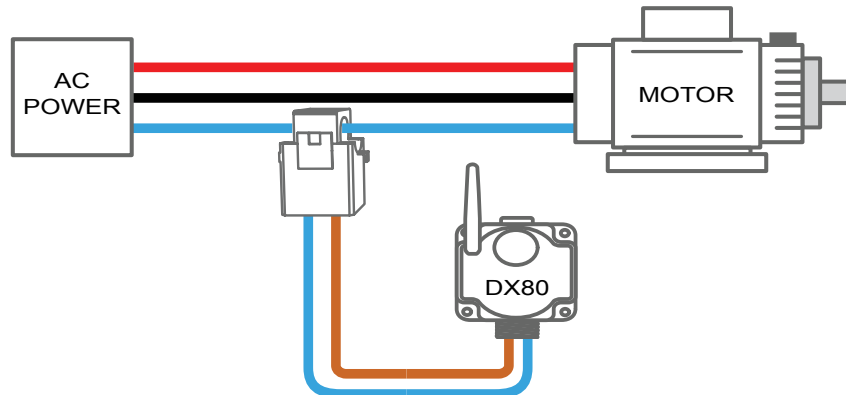

Installing a single conductor on the current transformer

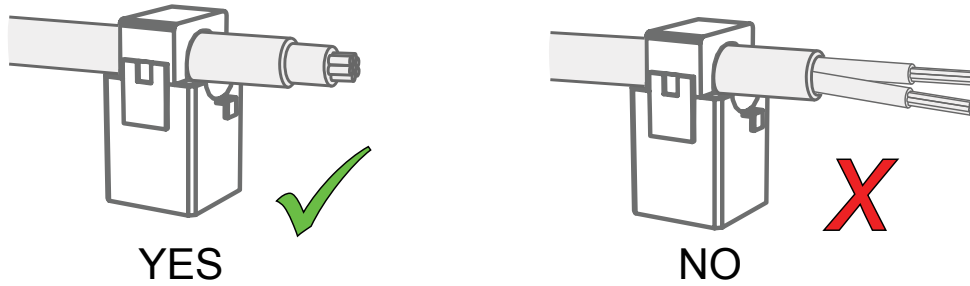

## Wire the Current Transformer

For more information on wiring and installing the current transformer, refer to the Split Core Current Transformer datasheet (p/n [212463](#)).

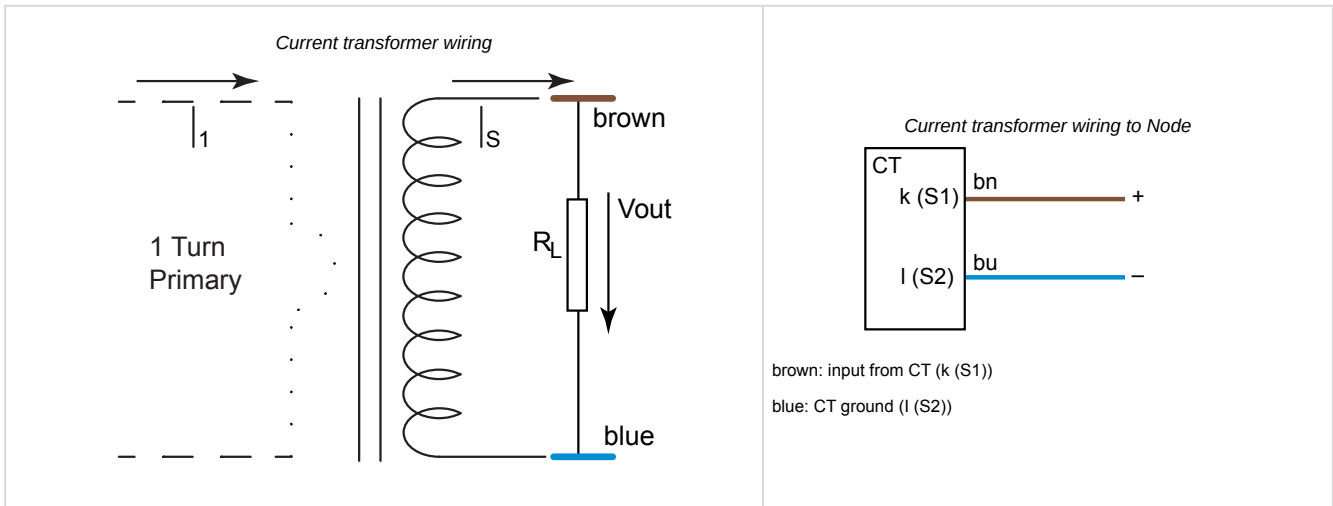

## Current Transformer Specifications

**Frequency**

50 to 2000 Hz

**Rating Input**

CT20A: 0–20A

CT150A: 0–150A

CT600A: 0–600A

**Rated Output**

0.333 V AC

**Measuring Range**

10% to 130% In

**Ratio**

≤ ±1%

**Inrush Current**

8x rated input for ≤ 0.1 s

**Phase Angle**

≤ ±60 min

**Dielectric Strength**

2.5 kV / 1 mA / 1 min

**Insulation Resistance**

DC5000 V / 1000 MOhm min

**Construction**

PA /UL94-VO case; PBT bobbin; silicon steel core; epoxy internal structure; tie construction

**Operating Conditions**

–25 °C to +75 °C (–13 °F to +167 °F)

85% relative humidity

**Accuracy Class**

0.5

**Certifications**



Banner Engineering BV  
Park Lane, Culliganlaan 2F bus 3  
1831 Diegem, BELGIUM



Turck Banner LTD Blenheim House  
Blenheim Court  
Wickford, Essex SS11 8YT  
GREAT BRITAIN