

## Features

Submersible pressure sensors measure hydrostatic pressure to determine the level of liquids in large tanks and outdoor storage reservoirs. Resting on the bottom of a tank or reservoir, the sensor provides an analog output that is proportional to the depth of the liquid being measured. The caged design of this sensor protects the measuring cell and prevents clogging while acting as a weight to secure the sensor to the bottom of the tank or reservoir. Enables real-time, easy-to-deploy liquid level measurement for wastewater, slurry, sump, reservoir, and bulk storage tank applications.

- 0 to 15 PSI(G) (34.6 ft. of water)
- Vented cable with flying leads
- 10 V DC to 33 V DC
- Output 4 to 20 mA
- 316 stainless steel housing

## Models

Model	Description	Connection
<b>BWA-PRESSURE-SENSOR-15L</b>	Includes one PS15G60S 0–15 psi pressure sensor with a protective cage	2-wire flying leads with vent, 60 ft

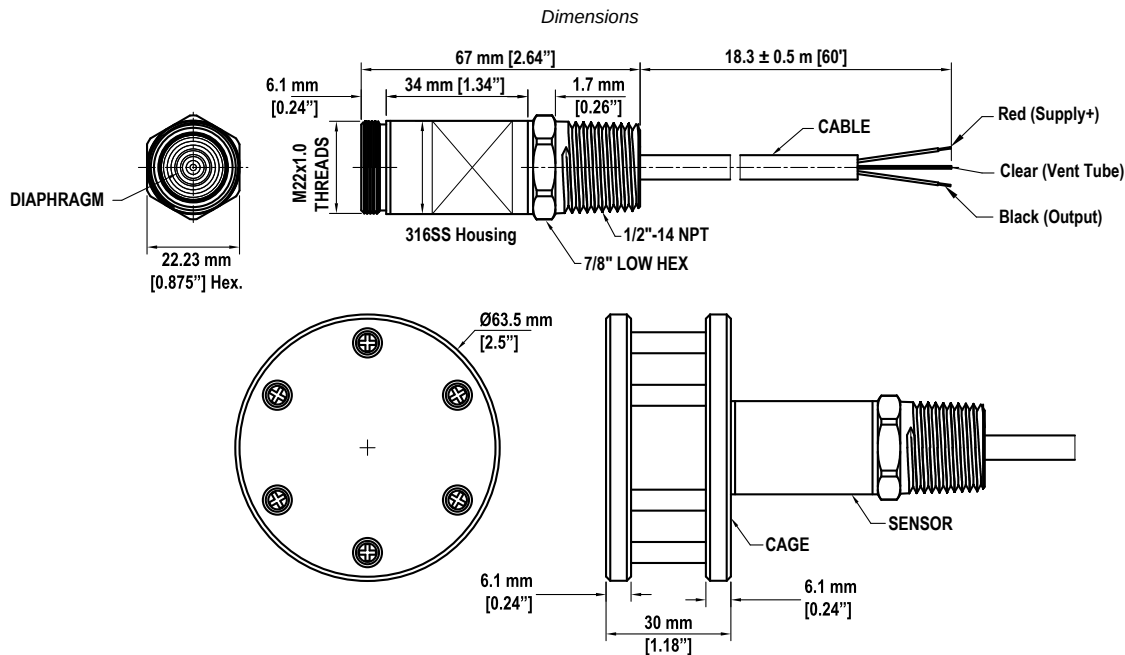

## Specifications for the Submersible Pressure Sensor

### Supply Voltage

10 V DC to 33 V DC

### Current Consumption

< 24 mA

### Pressure Range

0 to 15 PSI(G)

Proof pressure: 2x full scale

Burst pressure: 3x full scale

### Output

4 to 20 mA

### Accuracy

± 1% BFSL

### Stability

± 0.25% per year

### Temperature

Compensated: 0 °C to +55 °C (+32 °F to +131 °F)

Operating: -40 °C to +85 °C (-40 °F to +185 °F)

### Tolerance

Zero Offset: ± 1%

Span: ± 1.5%

### Fatigue Life

> 4 million cycles

### Connection

M22 x 1 port

### Composition

Housing: 316 stainless steel

Wetted material: 316 stainless steel and PVC

### Environmental Rating

IP68

## Banner Engineering Corp Limited Warranty

---

Banner Engineering Corp. warrants its products to be free from defects in material and workmanship for one year following the date of shipment. Banner Engineering Corp. will repair or replace, free of charge, any product of its manufacture which, at the time it is returned to the factory, is found to have been defective during the warranty period. This warranty does not cover damage or liability for misuse, abuse, or the improper application or installation of the Banner product.

**THIS LIMITED WARRANTY IS EXCLUSIVE AND IN LIEU OF ALL OTHER WARRANTIES WHETHER EXPRESS OR IMPLIED (INCLUDING, WITHOUT LIMITATION, ANY WARRANTY OF MERCHANTABILITY OR FITNESS FOR A PARTICULAR PURPOSE), AND WHETHER ARISING UNDER COURSE OF PERFORMANCE, COURSE OF DEALING OR TRADE USAGE.**

This Warranty is exclusive and limited to repair or, at the discretion of Banner Engineering Corp., replacement. **IN NO EVENT SHALL BANNER ENGINEERING CORP. BE LIABLE TO BUYER OR ANY OTHER PERSON OR ENTITY FOR ANY EXTRA COSTS, EXPENSES, LOSSES, LOSS OF PROFITS, OR ANY INCIDENTAL, CONSEQUENTIAL OR SPECIAL DAMAGES RESULTING FROM ANY PRODUCT DEFECT OR FROM THE USE OR INABILITY TO USE THE PRODUCT, WHETHER ARISING IN CONTRACT OR WARRANTY, STATUTE, TORT, STRICT LIABILITY, NEGLIGENCE, OR OTHERWISE.**

Banner Engineering Corp. reserves the right to change, modify or improve the design of the product without assuming any obligations or liabilities relating to any product previously manufactured by Banner Engineering Corp. Any misuse, abuse, or improper application or installation of this product or use of the product for personal protection applications when the product is identified as not intended for such purposes will void the product warranty. Any modifications to this product without prior express approval by Banner Engineering Corp will void the product warranties. All specifications published in this document are subject to change; Banner reserves the right to modify product specifications or update documentation at any time. Specifications and product information in English supersede that which is provided in any other language. For the most recent version of any documentation, refer to: [www.bannerengineering.com](http://www.bannerengineering.com).

For patent information, see [www.bannerengineering.com/patents](http://www.bannerengineering.com/patents).

Document title: Submersible Pressure Sensor Datasheet

Part number: 219716

Revision: B

Original Instructions

© Banner Engineering Corp. All rights reserved.



219716