

CLAMP_CXA25-30

Basepart for reflectors and lenses with A-type interface. Compatible with CREE CXA/B25xx and CXA/B30xx.

SPECIFICATION:

| | |
|----------------|-----------|
| Dimensions | Ø 50.0 mm |
| Height | 9.3 mm |
| Fastening | screw |
| ROHS compliant | yes ⓘ |



MATERIALS:

| Component | Type | Material | Colour | Finish |
|----------------|-----------|----------|--------|--------|
| CLAMP_CXA25-30 | Base part | PC | white | |

ORDERING INFORMATION:

| Component | Qty in box | MOQ | MPQ | Box weight (kg) |
|---|------------|-----|-----|-----------------|
| C14036_CLAMP_CXA25-30 » Box size: 380 x 280 x 270 mm | 240 | 60 | 10 | 5.1 |

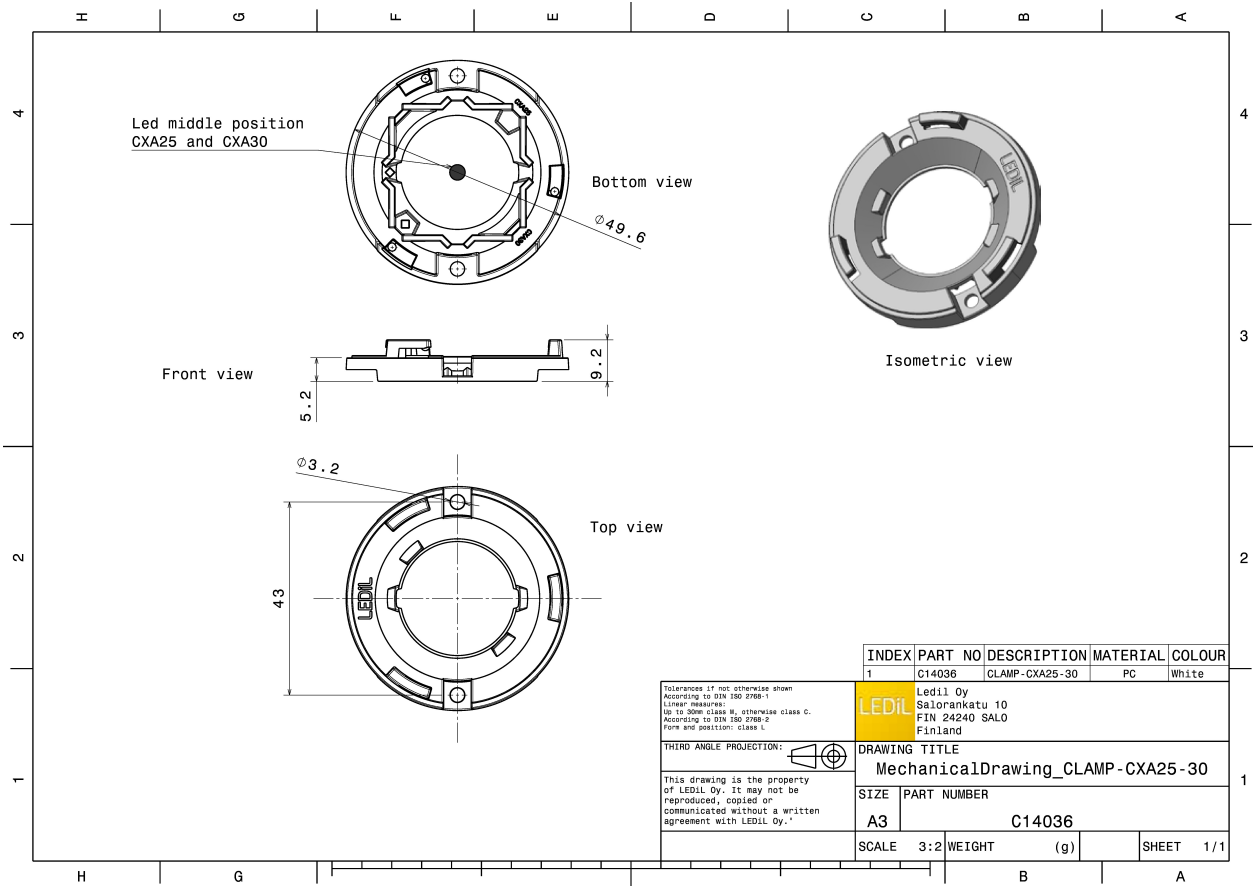

See also our general installation guide: www.ledil.com/installation_guide