

CLAMP-CXA15-18

Basepart for reflectors and lenses with A-type interface. Compatible with CREE CXA/B 15xx and CXA/B 18xx.

TECHNICAL SPECIFICATIONS:

Dimensions	Ø 49.6 mm
Height	9.3 mm
Fastening	screw
ROHS compliant	yes ⓘ

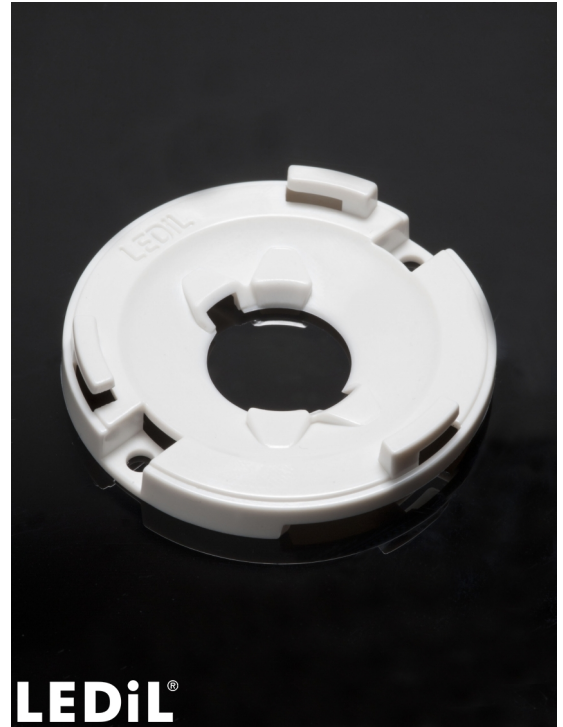

MATERIAL SPECIFICATIONS:

Component	Type	Material	Colour	Finish
CLAMP-CXA15-18	Base part	PC	white	

ORDERING INFORMATION:

Component	Qty in box	MOQ	MPQ	Box weight (kg)
C14123_CLAMP-CXA15-18 » Box size: 273 x 183 x 135 mm	180	60	60	0.8

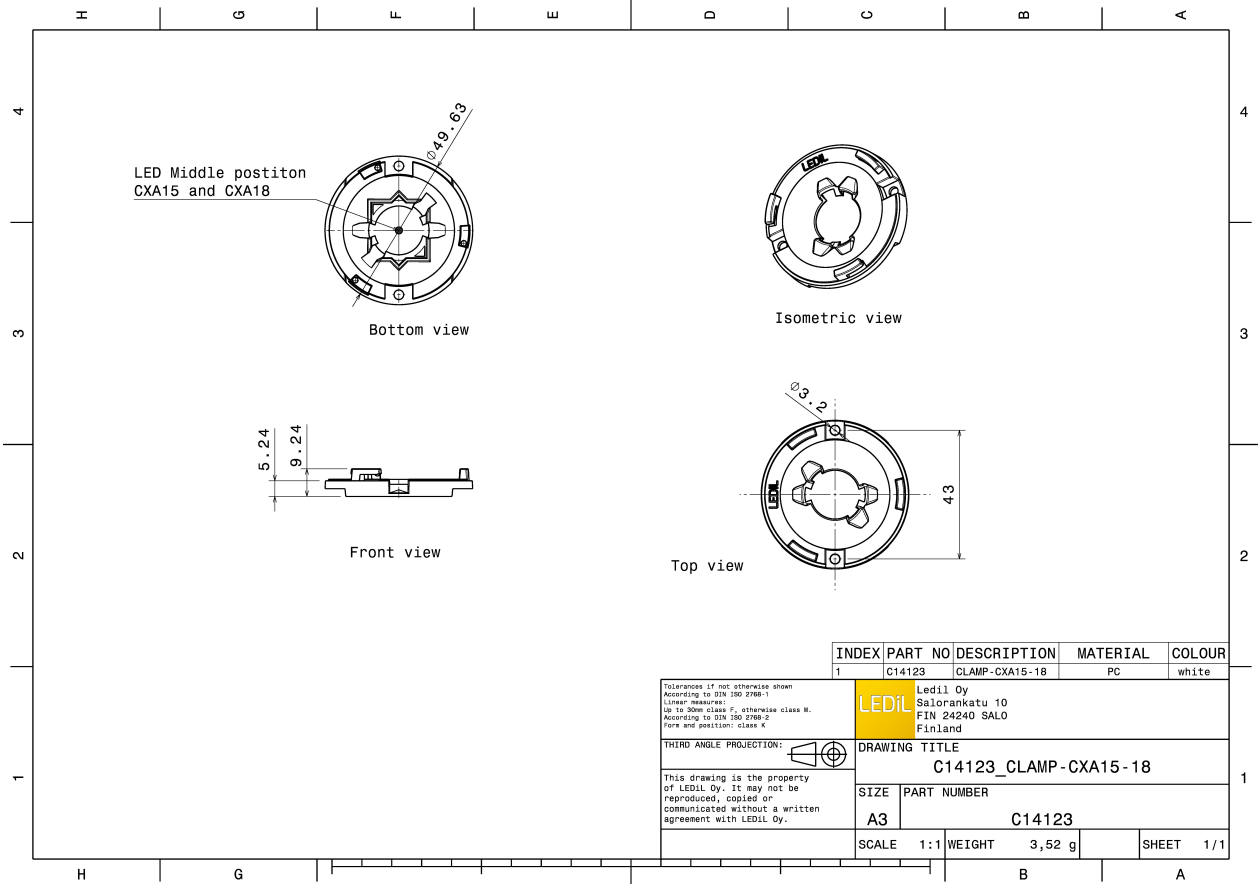

See also our general installation guide: www.ledil.com/installation_guide