

XTM-ADAPTER-50-A

Ø50 mm basepart for Xicato XTM/XIM modules compatible with LEDiL A-type interface.

SPECIFICATION:

Dimensions	Ø 50.0 mm
Height	12 mm
Fastening	screw
ROHS compliant	yes ⓘ

MATERIALS:

Component	Type	Material	Colour	Finish
XTM-ADAPTER-50-A	Base part	PC	white	

ORDERING INFORMATION:

Component	Qty in box	MOQ	MPQ	Box weight (kg)
C16491_XTM-ADAPTER-50-A » Box size: 400 x 300 x 300 mm	1000	100	100	5.4

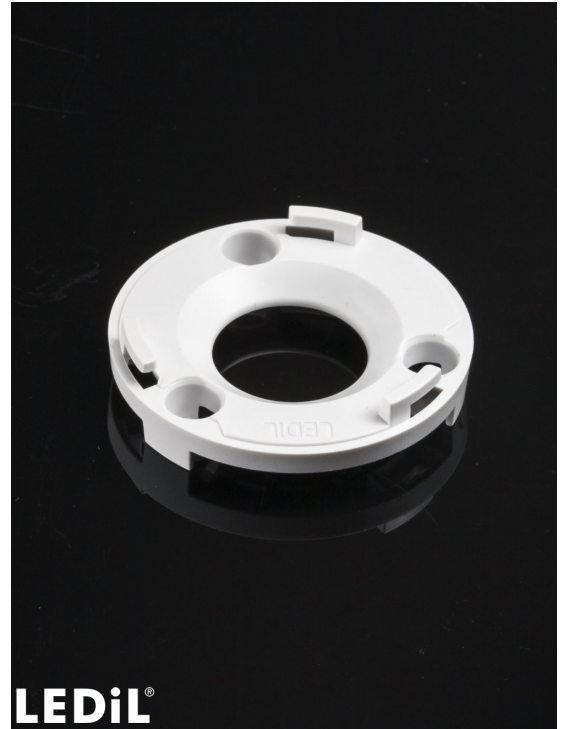

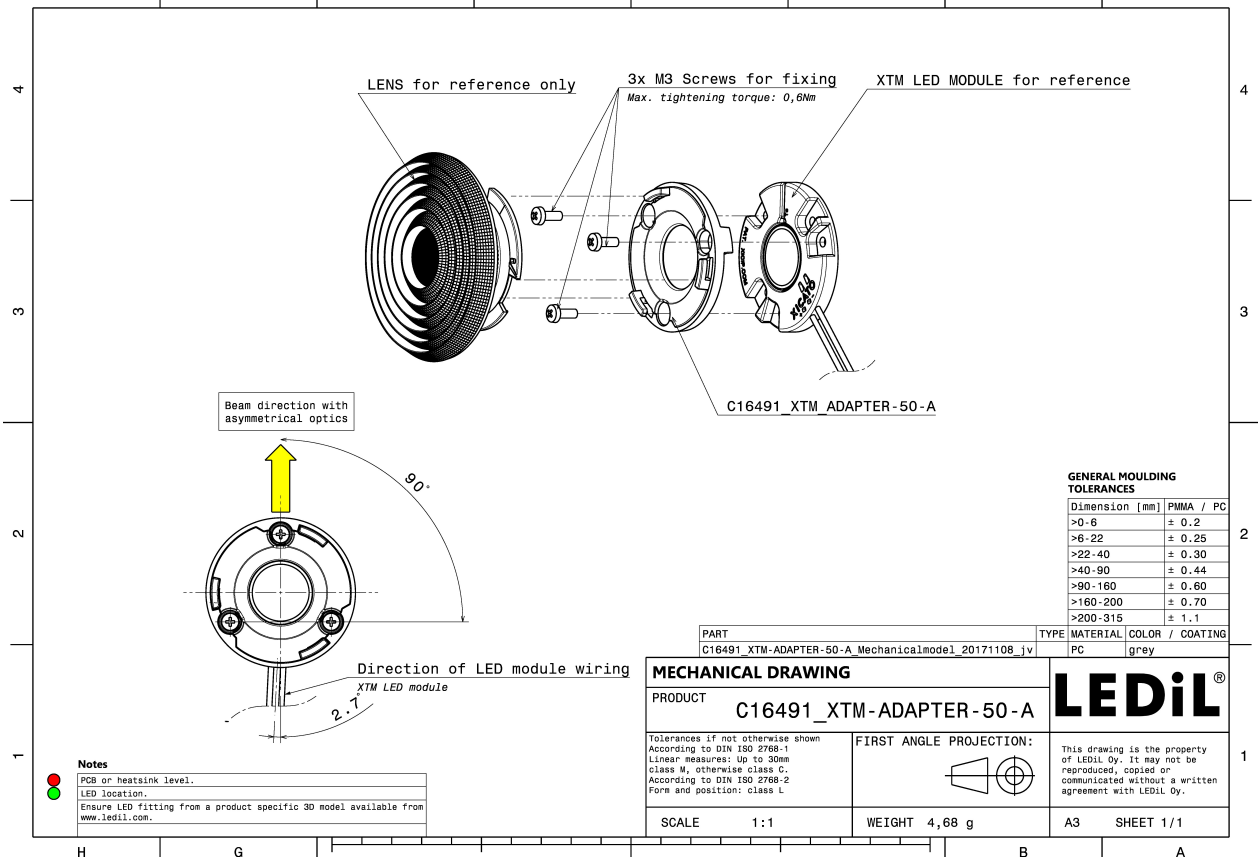
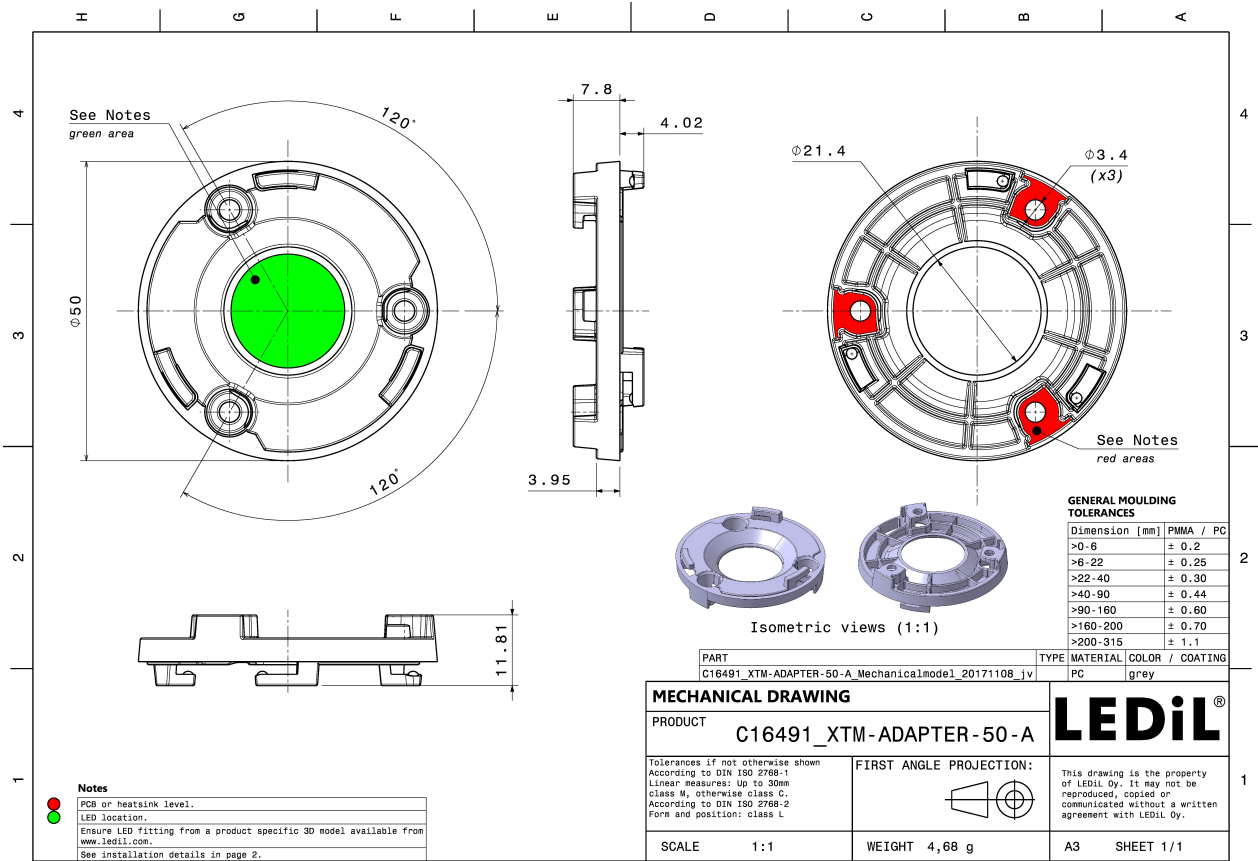

See also our general installation guide: www.ledil.com/installation_guide