

Surface Mount Termination
50 Watts, 50Ω



Description:

The C50A50Z4 is high performance Alumina (Al₂O₃) surface mount termination intended as a low cost alternative to Aluminum Oxide (AlN). The termination is well suited to all cellular frequency bands such as; AMPS, GSM, DCS, PCS, PHS and UMTS. The high power handling makes the part ideal for terminating high power 90 degree couplers, and for use in microstrip circuits. The termination is also RoHS compliant!

Features:

- RoHS Compliant
- 50 Watts
- DC – 2.7 GHz
- Al₂O₃ Ceramic
- Non-Nichrome Resistive Element
- Low VSWR
- 100% Tested
- Small Size

General Specifications:

Resistive Element	Thick film
Substrate	Al ₂ O ₃ Ceramic
Terminal Finish	Matte Tin over Nickel Barrier
Operating Temperature	-55 to +125°C (see de rating chart)

Electrical Specifications:

Resistance Value:	50 Ohms, ± 2%
Power:	50 Watts
Frequency Range:	DC – 2.7 GHz
Return Loss	> 26 dB to 2.2 GHz > 24 dB to 2.7 GHz

Specification based on unit properly installed using suggested mounting instructions and a 50 ohm nominal impedance. **Specifications subject to change.**

Outline Drawing:

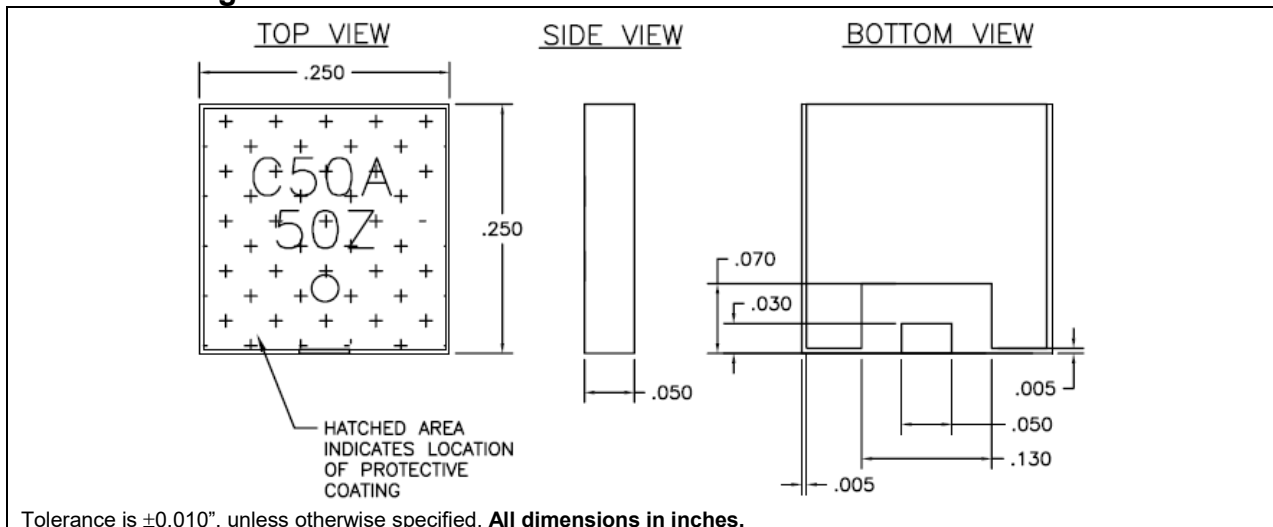

Typical Performance:

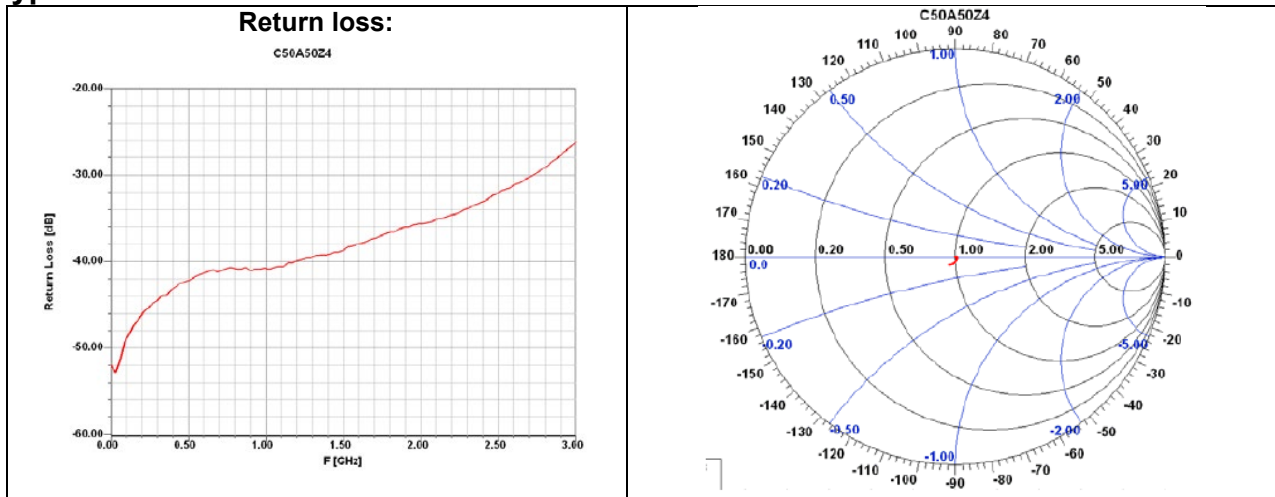

Power de-rating:

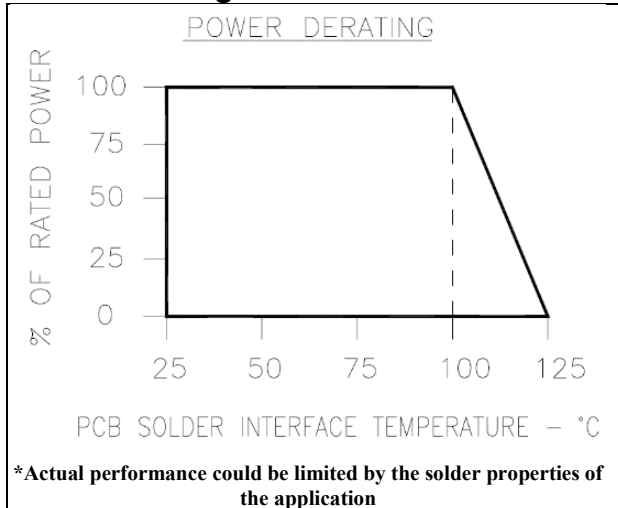

Mounting Footprint:

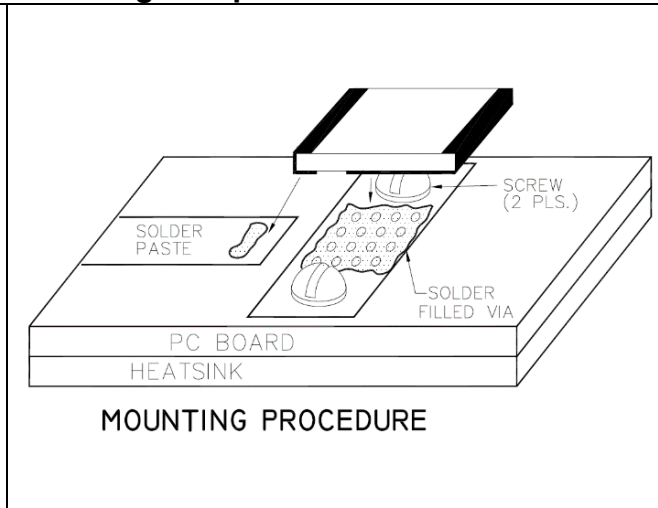

Tape & Reel:

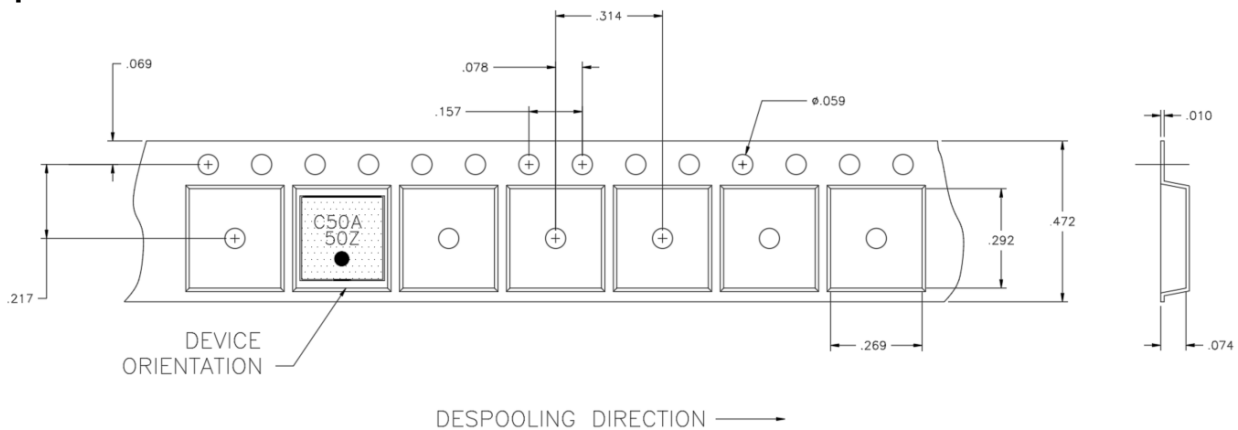

Contact us:
rf&s_support@ttm.com