

Proximity Sensors Capacitive Thermoplastic Polyester Housing Types CA, M18, M30, DC, Teach-in

TRIPLESHIELD™

CARLO GAVAZZI



- Featuring **TRIPLESHIELD™** Sensor Protection
- Sensing distance: 0.5 - 12 mm (M18) and 1.0 - 30 mm (M30)
- Teach-in of sensing distance via push-button or COM-input
- Automatic detection of NPN or PNP load
- Selectable make or break switching by means of Teach-in function
- Protection: Short-circuit, transients and reverse polarity
- Humidity compensation
- Alarm output
- 5 years of warranty

Product Description

Capacitive proximity switches with a sensing distance of either 8 mm flush mounted in metal or 12 mm non-flush mounted for the M18 version, and either 16 mm flush mounted in metal or 30 mm non-flush mounted for the M30 version.

The switching points can be altered by means of the Teach-in function. 3-wire DC output with selectable make (NO) or break (NC) switching and NPN Alarm. Grey poly-ester housing with 2 m PVC cable or M12 plug.

Ordering Key

CA18CLC12BPM1

Capacitive proximity switch	CA
Housing diameter (mm)	18
Housing material	CLC
Housing length	12
Detection principle	B
Rated operating dist. (mm)	12
Output type	P
Output configuration	M
Connection type	1

Type Selection

Housing diameter	Rated operating distance (S _n)	Ordering no. Cable	Ordering no. Plug
M18	12 mm	CA18CLC12BP	CA18CLC12BPM1
M30	30 mm	CA30CLC30BP	CA30CLC30BPM1

Specifications

Sensing range (S_d) CA18CLC12	0.5 - 12 mm factory set at 8 mm	Frequency of operating cycles (f)	15 Hz
CA30CLC30	1.0 - 30 mm factory set at 15 mm	Indication For output ON For safe/unsafe	LED, yellow LED, green
Sensitivity	Adjustable (Teach-in)	Environment Degree of protection Operating temperature Storage temperature	IP 68 -20° to +85°C (-4° to +185°F) -40° to +85°C (-40° to +176°F)
Effective operating dist. (S_r)	0.9 x S _n ≤ S _r ≤ 1.1 x S _n	Housing material Body Cable end Nuts	Grey, thermoplastic polyester Polyester, softened Black, PA12 Grilamid
Usable operating dist. (S_u)	0.8 x S _r ≤ S _u ≤ 1.2 x S _r	Connection Cable	Grey, 2 m, 4 x 0.25 mm ² Oil proof, PVC
Repeat accuracy (R)	≤ 5%	Plug (M1) Cable for plug (M1)	M12 x 1 CON.1A-series
Hysteresis (H)	Depending on Teach-in	Weight Cable version - M18 / M30 Plug version - M18 / M30	110 g/160 g 30 g/70 g
Rated operational volt. (U_B)	10 to 40 VDC (ripple incl.)	Approvals	UL, CSA
Ripple	≤ 10%	CE-marking	Yes
Rated operational current (I_a)	≤ 250 mA (continuous)		
No-load supply current (I_o)	≤ 12 mA		
Voltage drop (U_d)	≤ 2.5 VDC @ max. load		
Protection	Short-circuit, reverse polarity, transients		
TRIPLESHIELD™ protection-EMC IEC 1000-4-2/EN 61000-4-2 IEC 1000-4-3/EN 61000-4-3 IEC 1000-4-4/EN 61000-4-4 IEC 1000-4-6/EN 61000-4-6	30 kV > 15 V/m 3 kV > 10 V _{rms}		

Dimensions

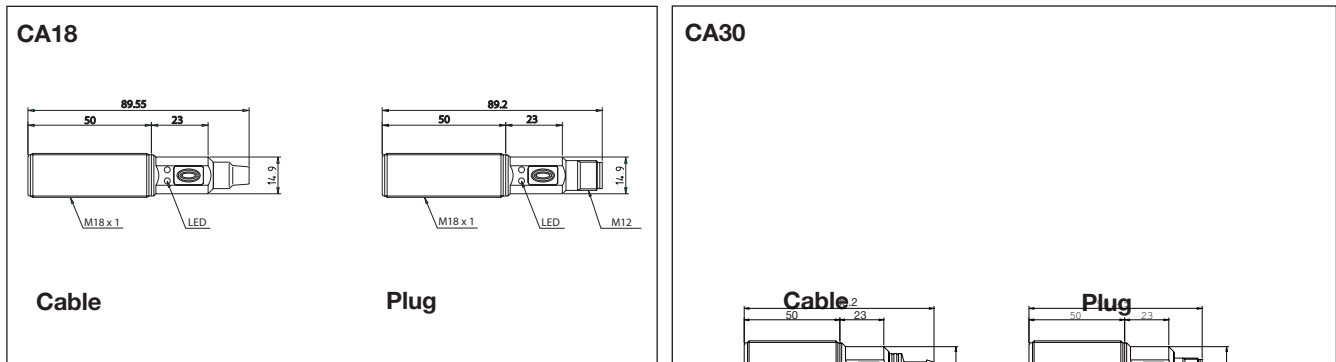

Adjustment Guide

The environments in which capacitive sensors are installed can often be unstable regarding temperature, humidity, object distance and industrial (noise) interference. Because of this, Carlo Gavazzi offers as standard features in all

TRIPLESHIELD™ capacitive sensors a user-friendly sensitivity adjustment instead of having a fixed sensing range, extended sensing range to accommodate mechanically demanding areas, temperature stability to ensure minimum

need for adjusting sensitivity if temperature varies and high immunity to electromagnetic interference (EMI).

Note: Sensors are factory set (default) to nominal sensing range S_n .

Installation Hints

Capacitive sensors have the unique ability to detect almost all materials, either in liquid or solid form. Capacitive sensors can detect metallic as well as non-metallic objects, however, their traditional use is for non-metallic materials such as:

- **Plastics Industry**
Resins, regrinds or mould-

- ed products.
- **Chemical Industry**
Cleansers, fertilisers, liquid soaps, corrosives and petrochemicals.
- **Wood Industry**
Saw dust, paper products, door and window frames.
- **Ceramic & Glass Industry**
Raw material, clay or

- finished products, bottles.
 - **Packaging Industry**
Package inspection for level or contents, dry goods, fruits and vegetables, dairy products.
- Materials are detected due to their dielectric constant. The bigger the size of an object, the higher the density of material, the better or eas-

ier it is to detect the object. Nominal sensing distance for a capacitive sensor is referenced to a grounded metal plate (ST37). For additional information regarding dielectric ratings of materials please refer to Technical Information.

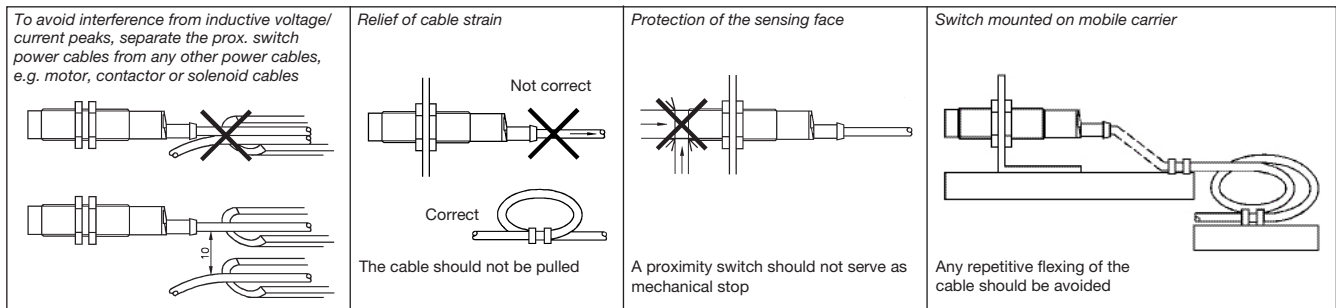

Delivery Contents

- Capacitive switch: CA..CLC..BP..
- **Packaging:** Cardboard box
- Installation & Adjustment Guide (MAN CAP ENG/GER)

Accessories

- Plugs CON.1A.. series.

For further information please refer to "Accessories."