

Features

- Low Noise Figure: 1.5 dB
- Medium Output Power: +18 dBm
- High Efficiency: 58 mA @ +5 V_{DC}
- pHEMT Amplifier

Description

The A6011 RF amplifier is a discrete hybrid design, which uses thin film manufacturing processes for accurate performance and high reliability.

This single stage GaAs FET feedback amplifier design displays impressive performance characteristics over a broadband frequency range. An RF choke is used for DC power supply decoupling.

Both the TO-8 and surface mount packages are hermetically sealed, and environmental screening is available per MIL-STD-883.

Product Image

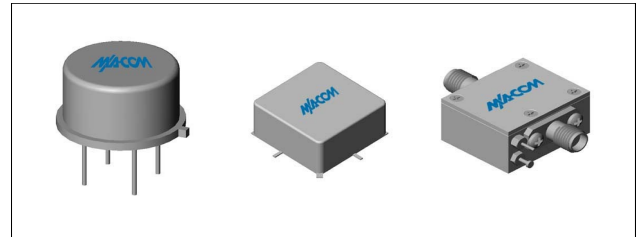

Ordering Information

Part Number	Package
A6011	TO-8
SMA6011	Surface Mount
CA6011 **	SMA Connectorized

** The connectorized version is not RoHS compliant.

Electrical Specifications: $Z_0 = 50 \Omega$, $V_{CC} = +5 V_{DC}$

Parameter	Units	Typical	Guaranteed	
		25°C	0° to 50°C	-54° to +85°C*
Frequency	GHz	1.5 - 6.0	2.0 - 6.0	2.0 - 6.0
Small Signal Gain (min.)	dB	14.8	13.5	12.5
Gain Flatness (max.)	dB	±0.6	±0.9	±1.1
Reverse Isolation	dB	16	—	—
Noise Figure (max.)	dB	1.5	2.5	3.0
Power Output @ 1 dB comp. (min.)	dBm	18.0	16.5	16.0
IP3	dBm	+30	—	—
IP2	dBm	+45	—	—
Second Order Harmonic IP	dBm	+50	—	—
VSWR Input / Output (max.)	Ratio	1.9:1 / 1.9:1	2.1:1 / 2.1:1	2.2:1 / 2.2:1
DC Current @ 5 Volts (max.)	mA	58	65	70

* Over temperature performance limits for part number CA6011, guaranteed from 0°C to +50°C only.

Absolute Maximum Ratings

Parameter	Absolute Maximum
Storage Temperature	-62°C to +150°C
Case Temperature	125°C
DC Voltage	+7 V
Continuous Input Power	+13 dBm
Short Term Input power (1 minute max.)	100 mW
Peak Power (3 μsec max.)	0.25 W
“S” Series Burn-In Temperature (case)	125°C

Thermal Data: $V_{CC} = +5 V_{DC}$

Parameter	Rating
Thermal Resistance θ_{jc}	47°C/W
Transistor Power Dissipation P_d	0.2 W
Junction Temperature Rise Above Case T_{jc}	+9.4°C

Typical Performance Curves

Gain

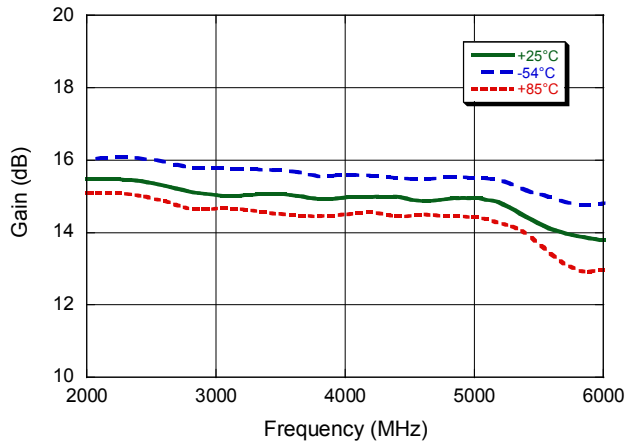

Noise Figure

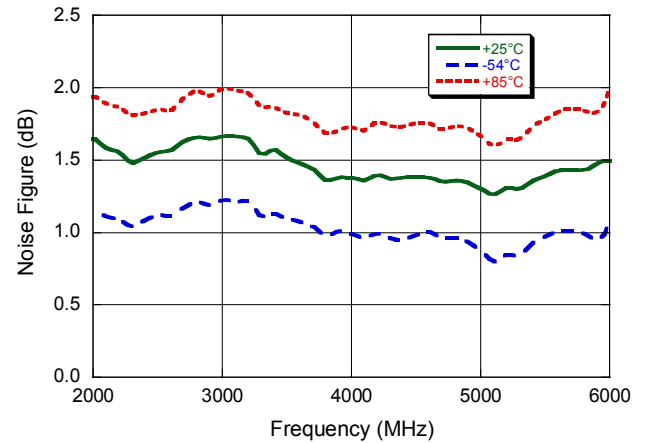

P_{OUT} @ 1 dB Gain Compression

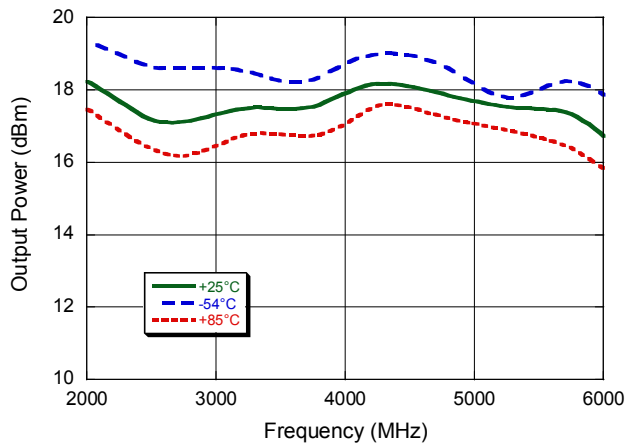

Intercept Points

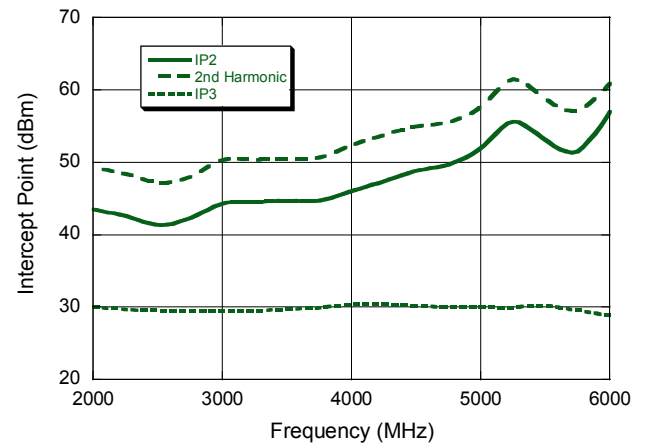

VSWR

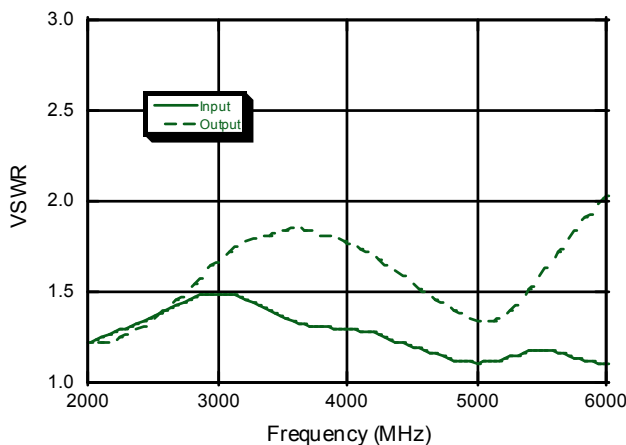

A6011 / SMA6011



Cascadable Amplifier
2000 to 6000 MHz

Rev. V5

Outline Drawing: TO-8 *

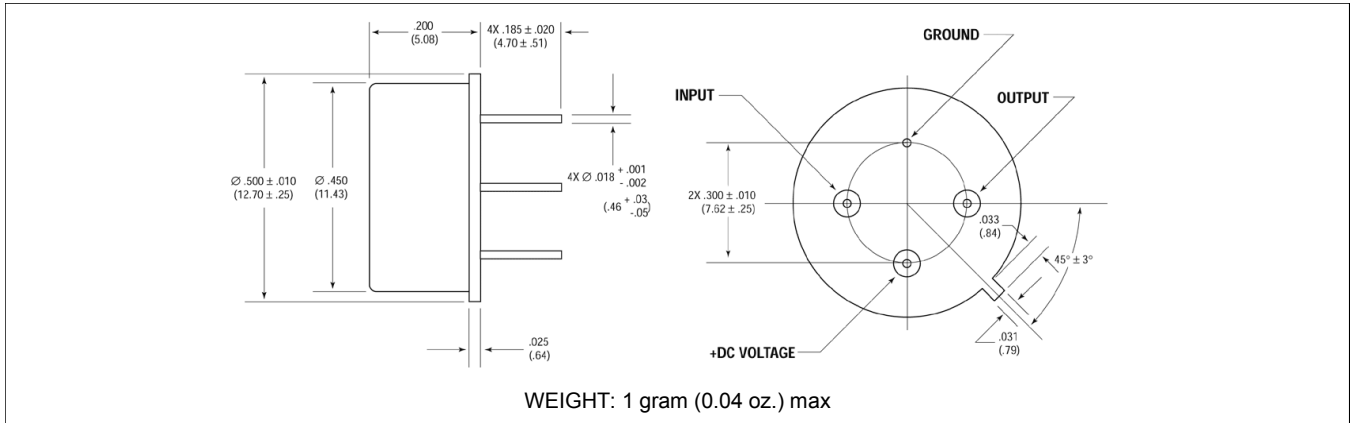

Outline Drawing: Surface Mount *

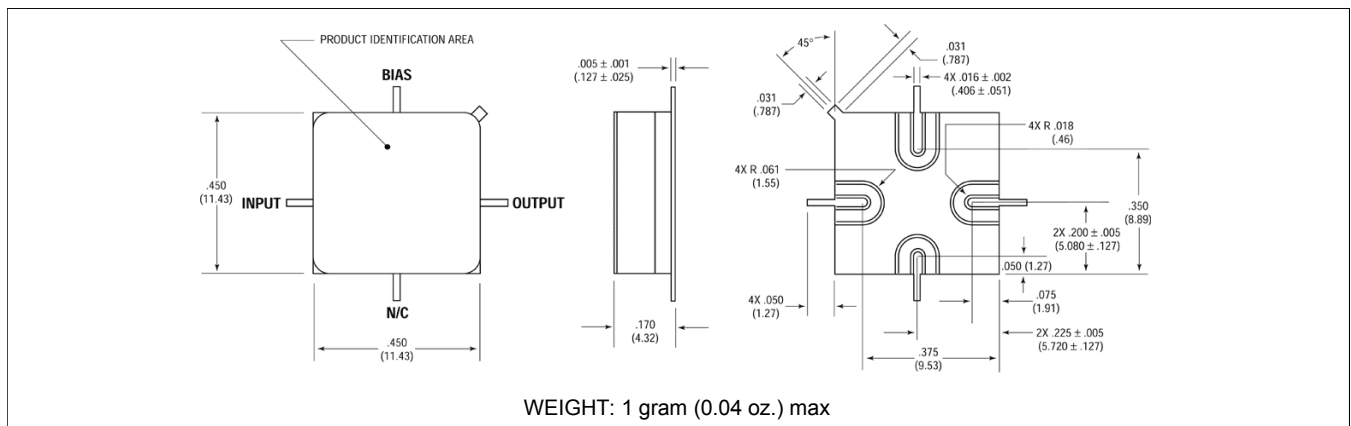

Outline Drawing: SMA Connectorized *

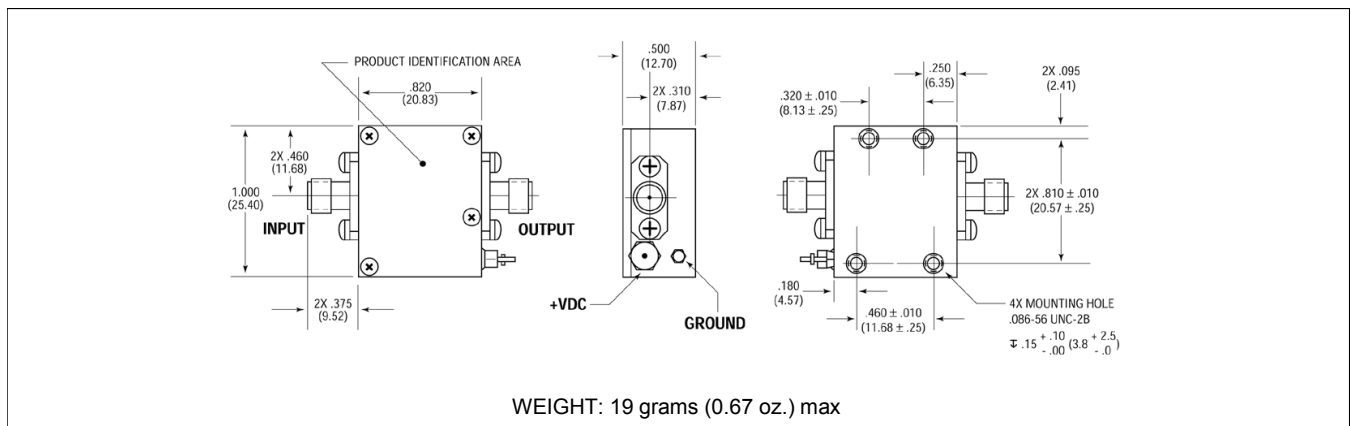

4

* Dimensions are inches (millimeters) ±0.015 (0.38) unless otherwise specified.

MACOM Technology Solutions Inc. (MACOM) and its affiliates reserve the right to make changes to the product(s) or information contained herein without notice. Visit www.macom.com for additional data sheets and product information.

For further information and support please visit:
<https://www.macom.com/support>

DC-0007963