

## Cascadable Amplifier 5 to 300 MHz

Rev. V3

### Features

- HIGH DYNAMIC RANGE: +116 dB/1 MHz
- HIGH OUTPUT POWER: +22 dBm (TYP.)
- HIGH THIRD ORDER I.P.: +38 dBm (TYP.)
- LOW NOISE FIGURE: 4.0 dB (TYP.)

### Description

The A79 RF amplifier is a discrete thin film hybrid design, which incorporates the use of thin film manufacturing processes for accurate performance and high reliability. This single stage bipolar transistor feedback amplifier design displays impressive performance over a broadband frequency range. An active DC biasing network is used for temperature-stable performance, in addition to an RF Choke, used for power supply decoupling. Both TO-8 and Surface Mount packages are hermetically sealed, and MIL-STD-883 environmental screening is available.

### Ordering Information

Part Number	Package
A79	TO-8
SMA79	Surface Mount
CA79**	SMA Connectorized

\*\* The connectorized version is not RoHs compliant.

### Product Image

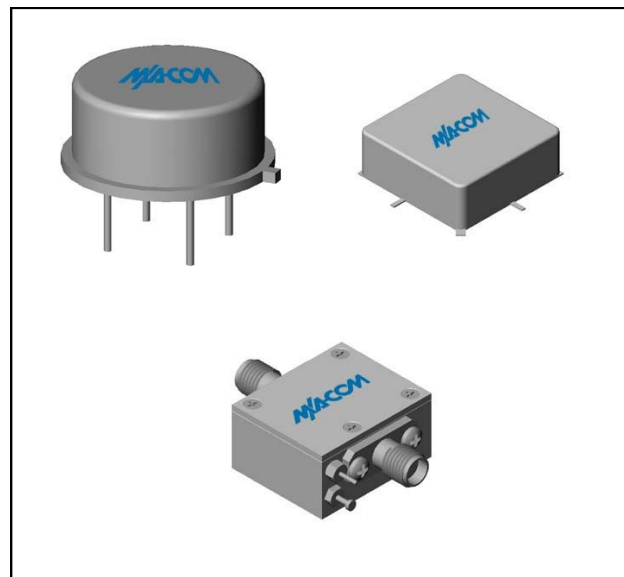

### Electrical Specifications: $Z_0 = 50\Omega$ , $V_{CC} = +15 V_{DC}$

Parameter	Units	Typical	Guaranteed	
		25°C	0° to 50°C	-54° to +85°C*
Frequency	MHz	2-350	5-300	5-300
Small Signal Gain (min)	dB	14.0	13.0	12.5
Gain Flatness (max)	dB	±0.3	±0.7	±1.0
Reverse Isolation	dB	18		
Noise Figure (max)	dB	4.0	5.0	5.5
Power Output @ 1 dB comp. (min)	dBm	22.0	20.5	20.0
IP3	dBm	+38		
IP2	dBm	+55		
Second Order Harmonic IP	dBm	+61		
VSWR Input / Output (max)		1.5:1 / 1.5:1	1.9:1 / 1.9:1	2.0:1 / 2.0:1
DC Current @ 15 Volts (max)	mA	88	93	98

### Absolute Maximum Ratings

Parameter	Absolute Maximum
Storage Temperature	-62°C to +125°C
Case Temperature	+125°C
DC Voltage	+17 V
Continuous Input Power	+18 dBm
Short Term Input power (1 minute max.)	100 mW
Peak Power (3 µsec max.)	0.5 W
"S" Series Burn-In Temperature (case)	+125°C

### Thermal Data: $V_{CC} = +15 V_{DC}$

Parameter	Rating
Thermal Resistance $\theta_{jc}$	75°C/W
Transistor Power Dissipation $P_d$	0.878 W
Junction Temperature Rise Above Case $T_{jc}$	+66°C

1 \* Over temperature performance limits for part number CA79, guaranteed from 0°C to +50°C only.

## Cascadable Amplifier 5 to 300 MHz

Rev. V3

### Typical Performance Curves at +25°C

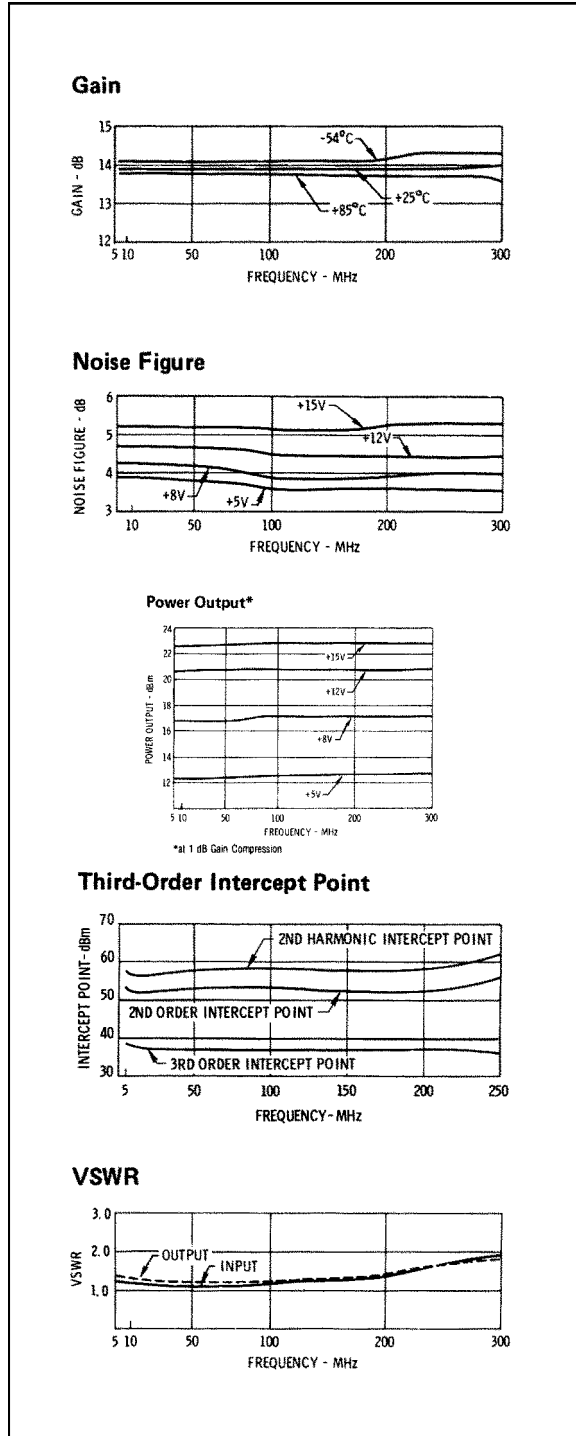

### Outline Drawing: TO-8 \*

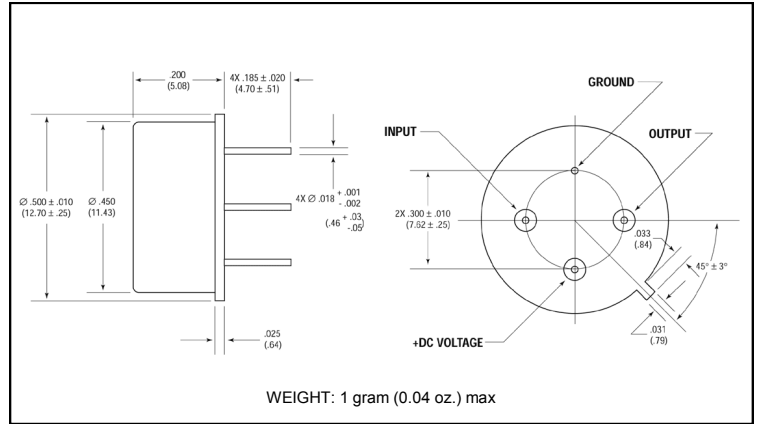

### Outline Drawing: TO-8 \*



### Outline Drawing: TO-8 \*

