

SPECIFICATION

Part No. : **CAB.S01**

Product Name : Taoglas Cable Assembly
IPEX MH4(HSC comp) to SMA(F)Bulkhead Straight Connector
with 100mm \varnothing 0.81 cable



1. Cable Insertion Loss

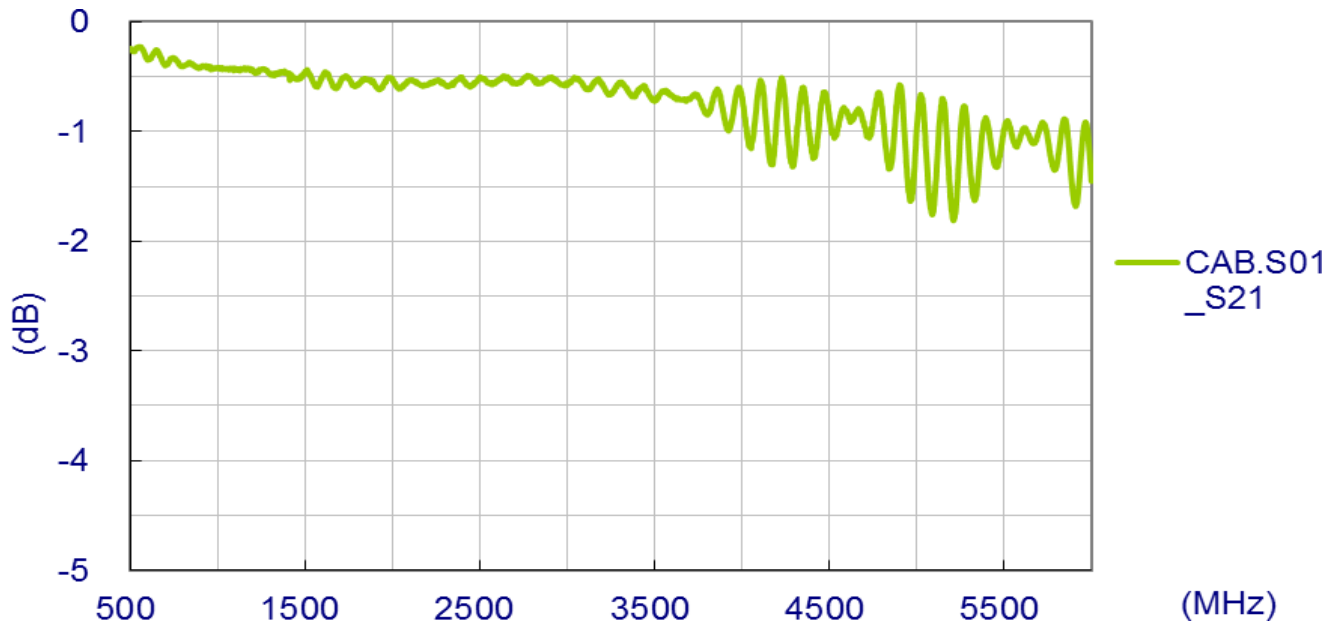

2. 0.81 Cable Specification

2.1 Drawing – Cross Section

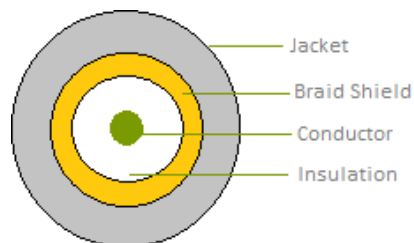

2.2 Structure and Dimensions

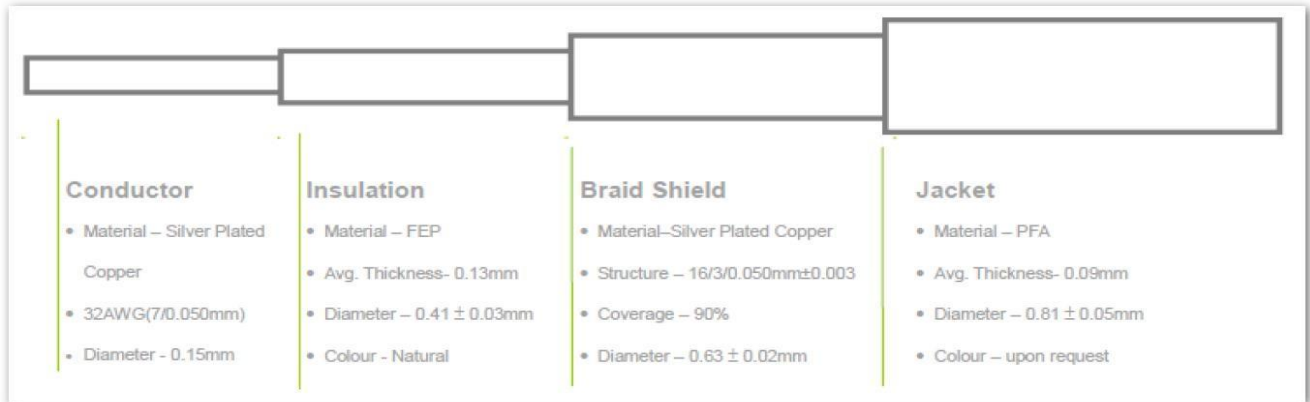

2.3 Electrical & Physical Specification

1	Insulation Resistance:	1000 MEGA OHM-KM Min.
2	Conductor Resistance:	1400 OHM/KM/20°C Max.
3	Dielectric Strength:	AC 1.0 KV/minute
4	Spark test:	2.5 KV
5	Nom. Impedance	50 ± 3 Ohms
6	Nom. Capacitance	97 ± 3 pF/m
7	Attenuation (dB/1M)	2.0GHz 3.60 2.4GHz 5.10 3.0GHz 6.20 4.0GHz 7.50 5.0GHz 8.50 6.0GHz 9.40

3. Technical Drawing

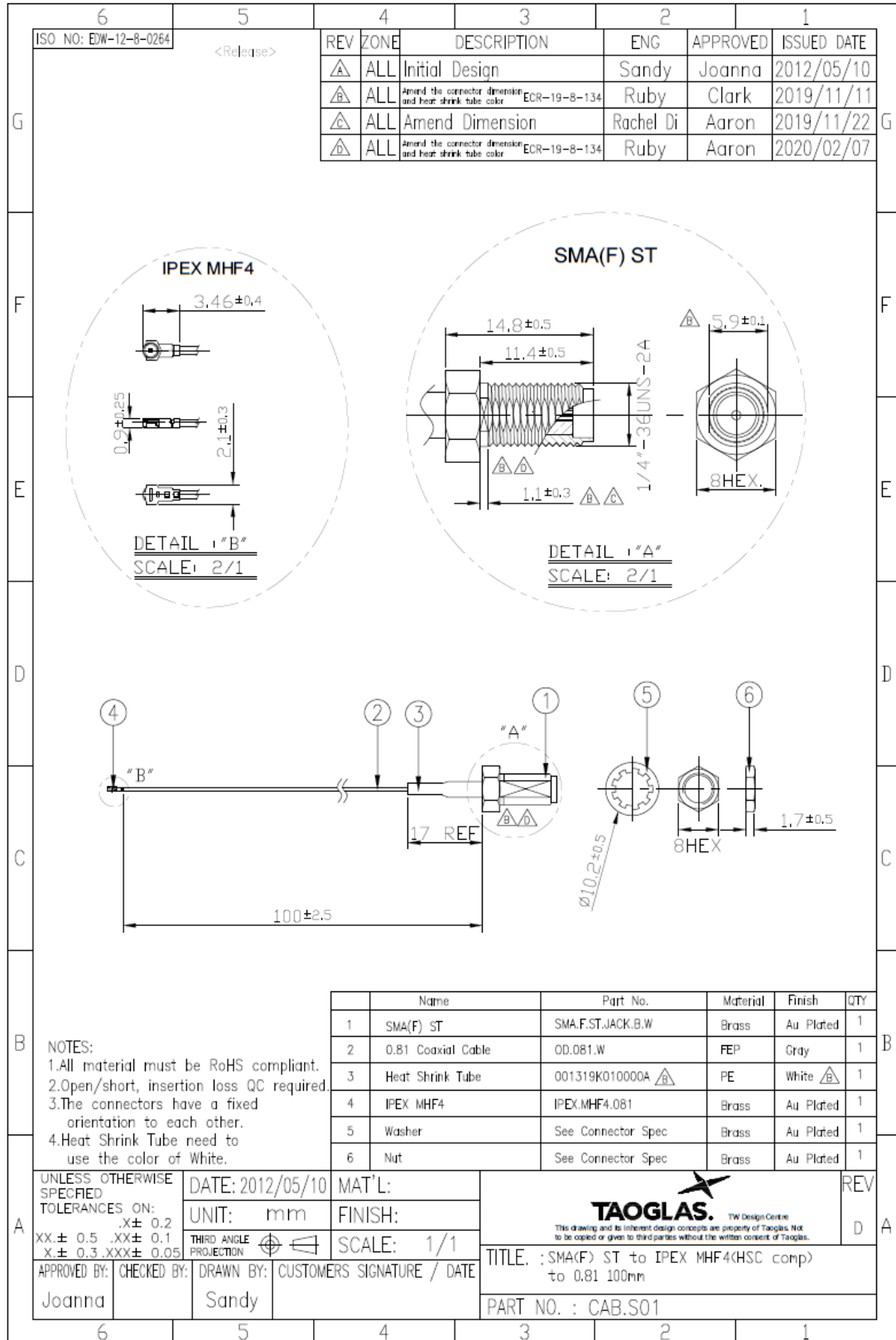

4. Packaging

