

CAR600M12HN6

1200 V, 600 A, Silicon Carbide, Half-Bridge Rectifier

V_R	1200 V
I_F	600 A

Technical Features

- Ultra-Low Loss, High Frequency Operation
- Low Forward Voltage (V_f) Drop with Positive Temperature Coefficient
- Zero Reverse Recovery Current
- Zero Forward Recovery Voltage
- Temperature-Independent Switching Behavior

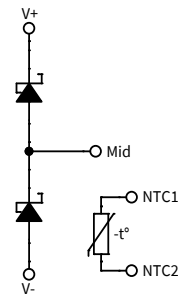

Applications

- Railway, Traction, and Motor Drives
- EV Chargers
- High-Efficiency Converters / Inverters
- Renewable Energy
- Smart-Grid / Grid-Tied Distributed Generation

System Benefits

- Enables Compact, Lightweight Systems
- Increased System Efficiency, due to Low Switching & Conduction Losses of SiC
- Reduced Thermal Requirements and System Cost

Maximum Parameters (Verified by Design)

Parameter	Symbol	Min.	Typ.	Max.	Unit	Test Conditions	Note
Maximum Reverse Voltage	V_{R-Max}			1200	V		
Continuous Forward Current	I_F		908		A	$T_C = 25^\circ\text{C}, T_{VJ} \leq 175^\circ\text{C}$	
			642			$T_C = 90^\circ\text{C}, T_{VJ} \leq 175^\circ\text{C}$	
Maximum Pulsed Forward Current	$I_{F(Pulsed)}$			1200		t_{Pmax} limited by T_{VJmax} $T_C = 25^\circ\text{C}$	
Maximum Virtual Junction Temperature	T_{VJ}	-40		175	$^\circ\text{C}$		



Diode Characteristics (Per Position) ($T_{VJ} = 25^{\circ}\text{C}$ unless otherwise specified)

Parameter	Symbol	Min.	Typ.	Max.	Unit	Test Conditions	Note
Diode Forward Voltage	V_F		1.5		V	$I_F = 600 \text{ A}$	
			2.0			$I_F = 600 \text{ A}, T_{VJ} = 175^{\circ}\text{C}$	
Reverse Current	I_R		0.16		mA	$V_R = 1200 \text{ V}, T_{VJ} = 25^{\circ}\text{C}$	
			0.90			$V_R = 1200 \text{ V}, T_{VJ} = 175^{\circ}\text{C}$	
Total Capacitive Charge	Q_C		3.5		mC	$V_R = 800 \text{ V}$	
Total Capacitance	C		45.3		nF	$V_R = 0 \text{ V}, f = 100 \text{ kHz}$	
			3.2			$V_R = 400 \text{ V}, f = 100 \text{ kHz}$	
			2.5			$V_R = 800 \text{ V}, f = 100 \text{ kHz}$	
Thermal Resistance, Junction to Case	R_{TH-JC}		0.063			Per position	

Note:

¹SiC Schottky diodes are majority carrier devices, so there is no reverse recovery charge.



Module Physical Characteristics

Parameter	Symbol	Min.	Typ.	Max.	Unit	Test Conditions
Package Resistance, M1 (High-Side)	R_{1-2}		106.5		$\mu\Omega$	$T_c = 125^\circ\text{C}$, Note 1
Package Resistance, M2 (Low-Side)	R_{2-3}		126.3			$T_c = 125^\circ\text{C}$, Note 1
Stray Inductance	L_{Stray}		4.9		nH	Between DC- and DC+, $f = 10 \text{ MHz}$
Case Temperature	T_c	-40		125	$^\circ\text{C}$	
Mounting Torque	M_s	3	4.5	5	N-m	Baseplate, M6 bolts
		0.9	1.1	1.3		Power Terminals, M4 bolts
Weight	W		167		g	
Case Isolation Voltage	V_{isol}	4			kV	AC, 50 Hz, 1 minute
Comparative Tracking Index	CTI	600				
Clearance Distance		13.07			mm	Terminal to Terminal
		6.00				Terminal to Heatsink
Creepage Distance		14.27				Terminal to Terminal
		12.34				Terminal to Heatsink

NTC Characteristics ($T_{\text{NTC}} = 25^\circ\text{C}$ unless otherwise specified)

Parameter	Symbol	Min.	Typ.	Max.	Unit	Notes
Resistance at 25°C	R_{25}		4700		Ω	
Tolerance of R_{25}			± 1		%	
Beta Value for 25°C to 85°C	$B_{25/85}$		3435		K	
Beta Value for 0°C to 100°C	$B_{0/100}$		3399		K	
Tolerance of $B_{25/85}$			± 1		%	
Maximum Power Dissipation	P_{Max}		50		mW	

Steinhart & Hart Coefficients for NTC Resistance & NTC Temperature Computation (T in K)

$$\ln\left(\frac{R}{R_{25}}\right) = A + \frac{B}{T} + \frac{C}{T^2} + \frac{D}{T^3}$$

$$\frac{1}{T} = A_1 + B_1 \ln\left(\frac{R}{R_{25}}\right) + C_1 \ln^2\left(\frac{R}{R_{25}}\right) + D_1 \ln^3\left(\frac{R}{R_{25}}\right)$$

A	B	C	D
-1.289E+01	4.245E+03	-8.749E+04	-9.588E+06

A_1	B_1	C_1	D_1
3.354E-03	3.001E-04	5.085E-06	2.188E-07



Typical Performance

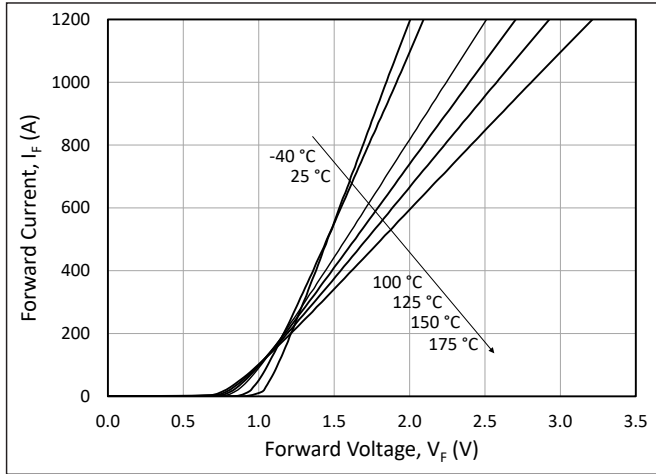

Figure 1. Typical Forward Characteristics

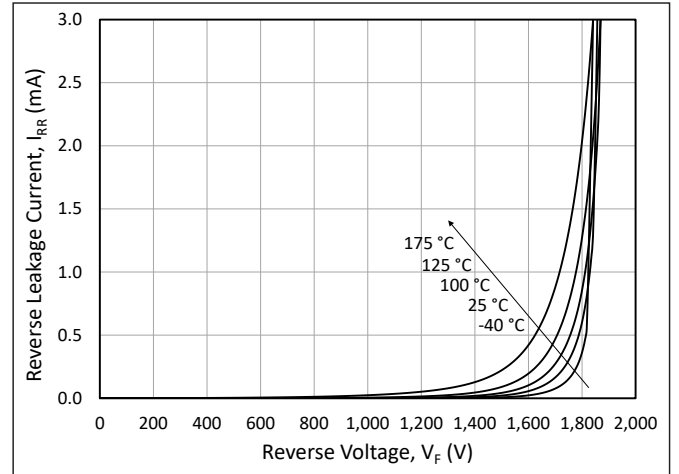

Figure 2. Typical Reverse Characteristics

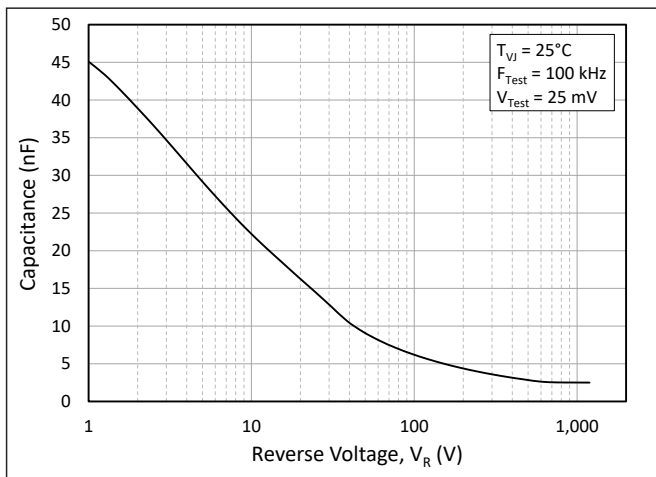

Figure 3. Typical Capacitance vs. Reverse Voltage

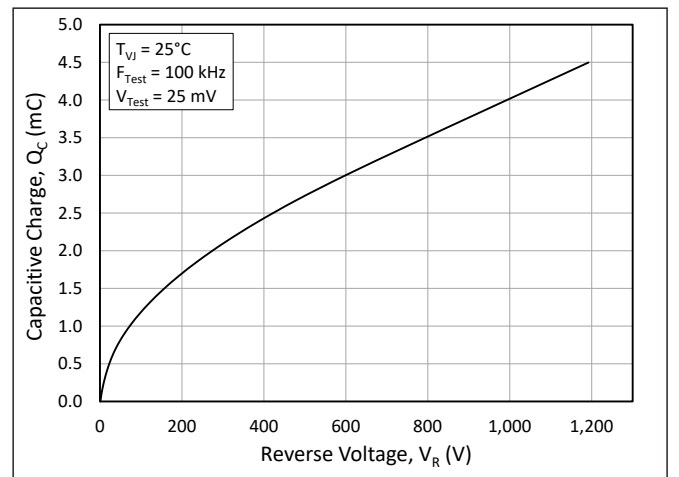

Figure 4. Typical Capacitive Charge vs. Reverse Voltage

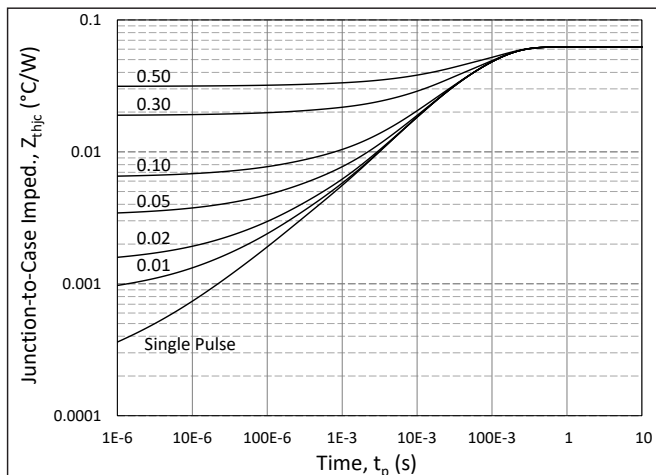

Figure 5. Diode Junction to Case Transient Thermal Impedance, Z_{thJC} (°C/W)

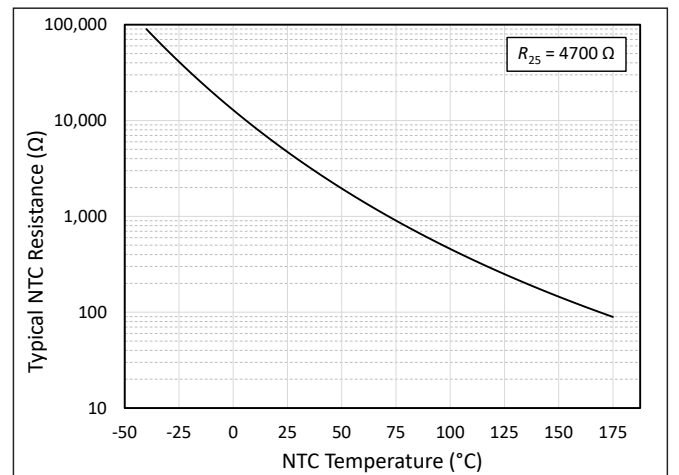
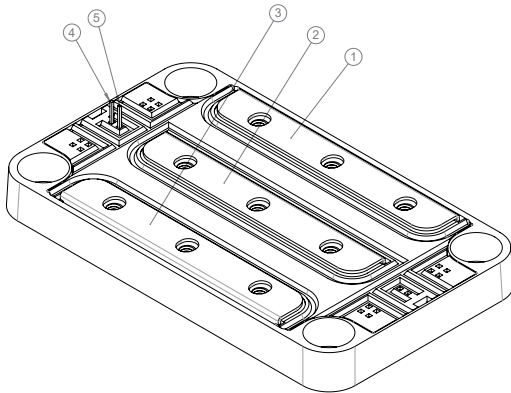

Figure 6. NTC Resistance vs. NTC Temperature



Schematic and Pin Out



PIN OUT SCHEME	
PIN	LABEL
①	V+
②	Mid
③	V-
④	NTC1
⑤	NTC2

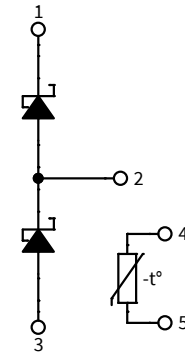

Package Dimension (mm)

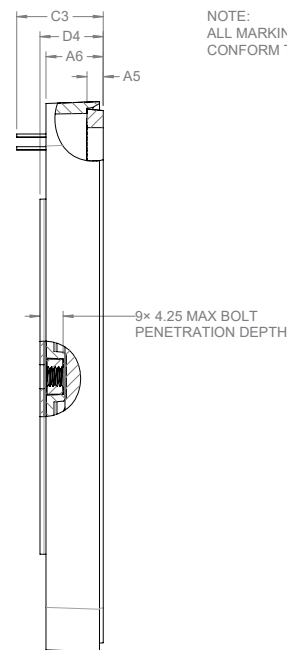
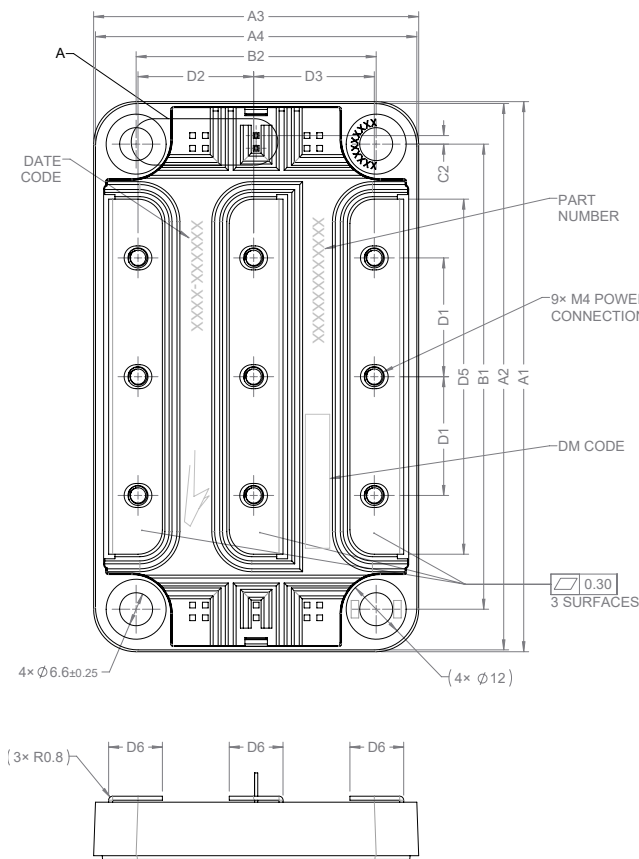

NOTE:
ALL MARKINGS SHALL
CONFORM TO PRC-00786.

DIMENSION TABLE		
SYMBOL	DIMENSION	TOLERANCE
A1	110.00	±0.60
A2	109.25	±0.60
A3	65.00	±0.60
A4	64.25	±0.60
A5	3.25	±0.30
A6	11.45	±0.60
B1	93.00	±0.30
B2	48.00	±0.30
C1	24.00	±0.40
C2	1.71	±0.40
C3	17.30	±0.50
C4	2.54	±0.30
C5	0.64	±0.30
D1	23.75	±0.50
D2	23.13	±0.50
D3	24.13	±0.50
D4	12.20	±0.50
D5	71.00	±0.30
D6	10.75	±0.30

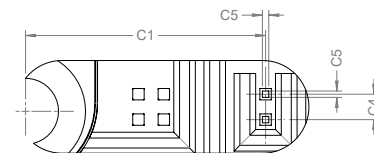

DETAIL A
SCALE: 4:1



Supporting Links & Tools

Evaluation Tools & Support

- [CAR600M12HN6 PLECS Model](#)
- [SpeedFit 2.0 Design Simulator™](#)
- [Technical Support Forum](#)

Application Notes

- [CPWR-AN35: 62mm Thermal Interface Material Application Note](#)
- [CPWR-AN39: KIT-CRD-CIL12N-HM User Guide](#)