

CDBQC0540L-HF High-Reliability and High-Performance

$I_o = 500 \text{ mA}$

$V_R = 40 \text{ V}$

RoHS Device
Halogen Free



Features

- Low forward voltage.
- Designed for mounting on small surface.
- Extremely thin package.
- Majority carrier conduction.

Mechanical data

- Case: 0402C/SOD-923F standard package, molded plastic.
- Terminals: Gold plated, solderable per MIL-STD-750, method 2026.
- Polarity: Indicated by cathode band.
- Mounting position: Any.
- Weight: 0.001 grams (approx.).

Circuit Diagram

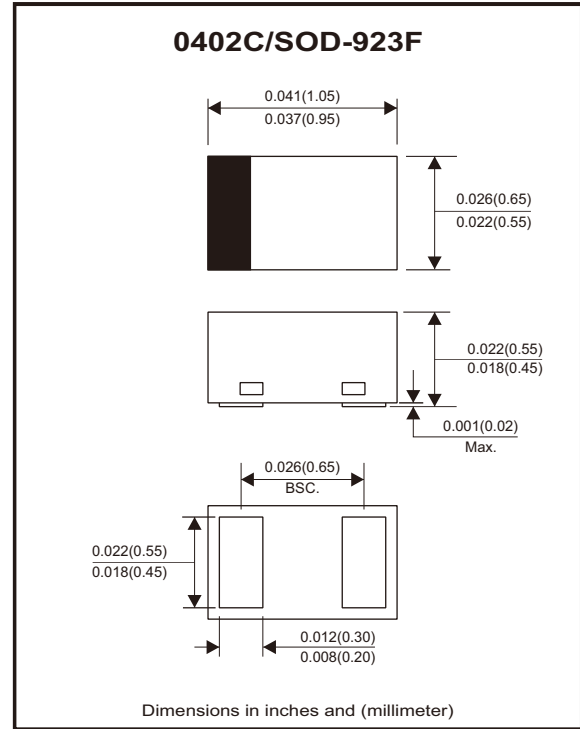

Maximum Rating (at $T_A=25^\circ\text{C}$ unless otherwise noted)

Parameter	Conditions	Symbol	Min	Typ	Max	Unit
Repetitive peak reverse voltage		V_{RRM}			40	V
Reverse voltage		V_R			40	V
Average forward rectified current		I_o			500	mA
Forward current, surge peak	8.3ms single half sine-wave superimposed on rate load (JEDEC method)	I_{FSM}			4.5	A
ESD rating	Human body model	ESD			8	kV
	Machine model				400	V
Power dissipation		P_D			500	mW
Thermal resistance	Junction to ambient	$R_{\theta JA}$		200		$^\circ\text{C/W}$
Junction temperature		T_j	-55		+150	$^\circ\text{C}$
Storage temperature		T_{STG}	-55		+150	$^\circ\text{C}$

Electrical Characteristics (at $T_A=25^\circ\text{C}$ unless otherwise noted)

Parameter	Conditions	Symbol	Min	Typ	Max	Unit
Forward voltage	$I_F = 100\text{mA}$	V_F		0.32	0.36	V
	$I_F = 500\text{mA}$			0.44	0.48	
Reverse current	$V_R = 10\text{V}$	I_R			15	μA
	$V_R = 40\text{V}$				40	
Capacitance between terminals	$V_R = 0\text{V}, f = 1\text{MHz}$	C_T		105		pF

Notes: Device mounted on a 20mm x 20mm ceramic PCB which spread 2 ounces of copper.

Typical Rating and Characteristic Curves (CDBQC0540L-HF)

Fig.1 - Forward Characteristics

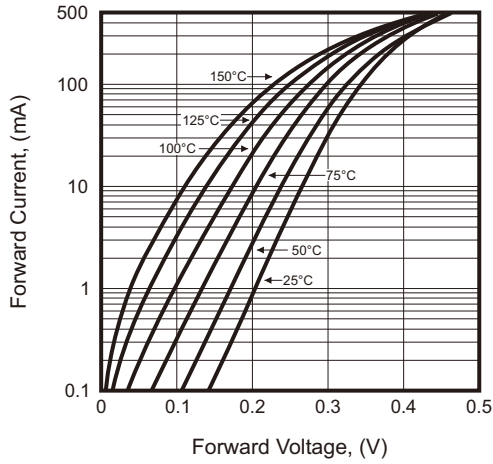

Fig.2 - Reverse Characteristics

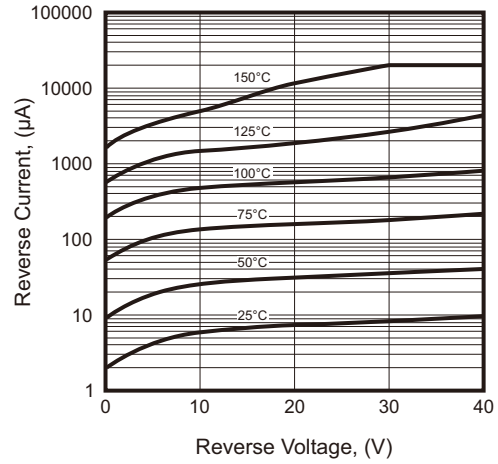

Fig.3 - Typical Capacitance Between Terminals Characteristics

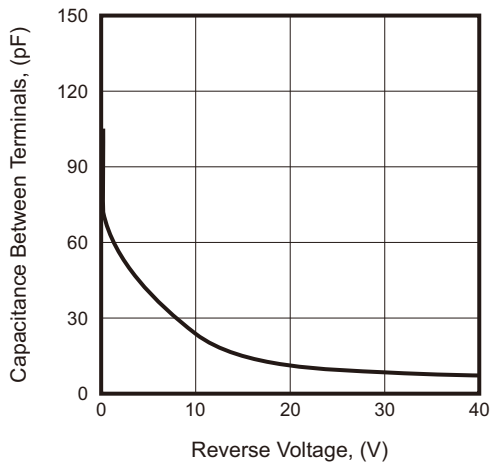

Fig.4 - Forward Current Derating Curve

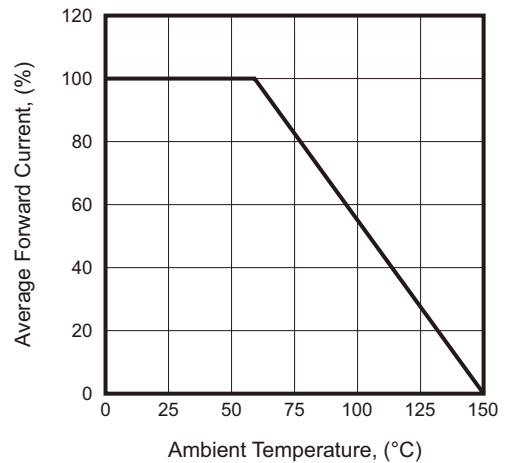
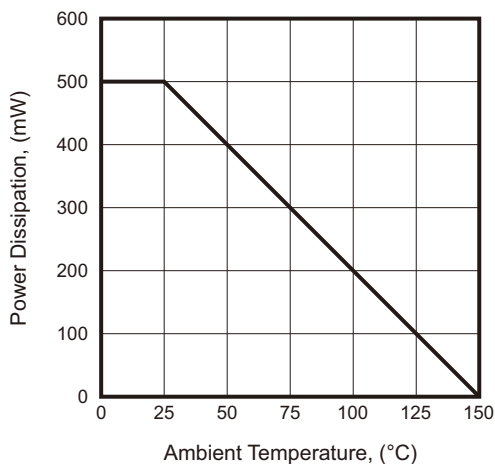
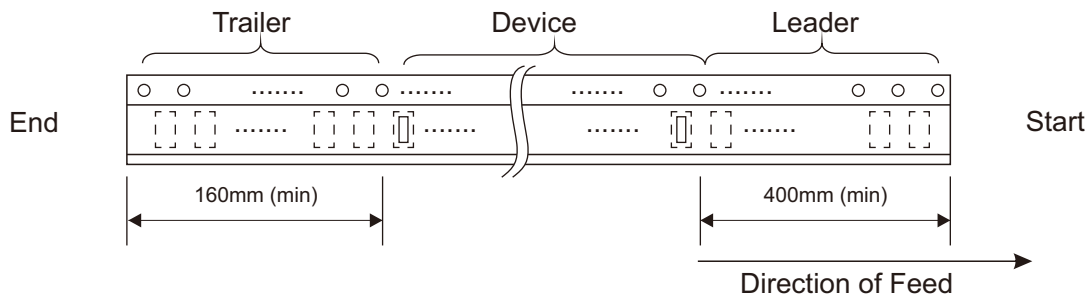
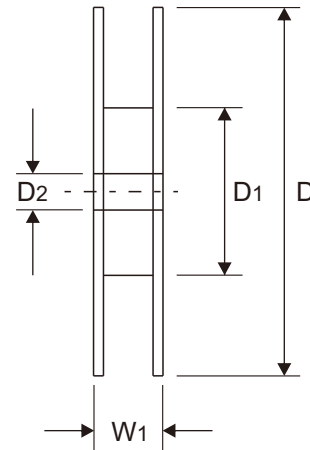
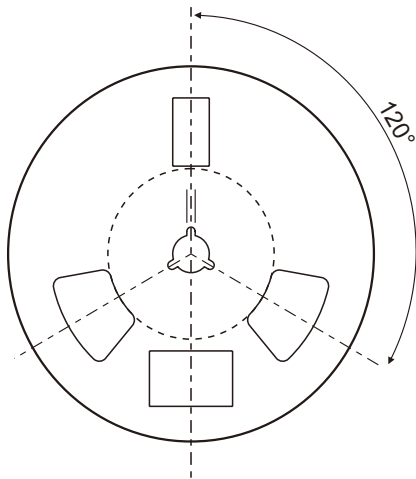
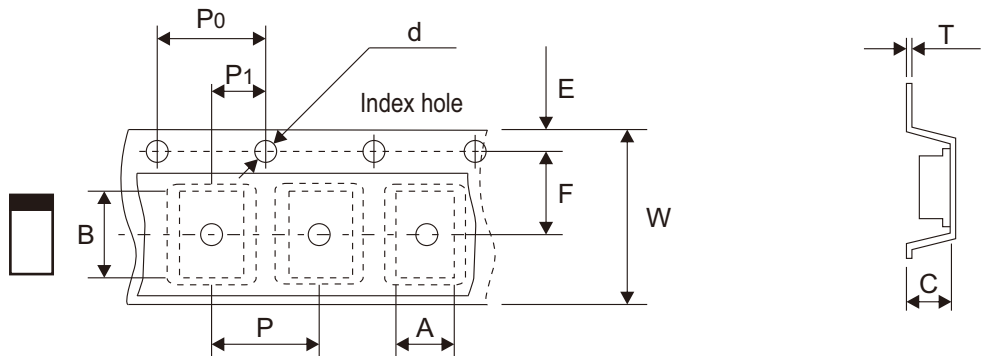

Fig.5 - Power Derating Curve



Reel Taping Specification



0402C (SOD-923F)	SYMBOL	A	B	C	d	D	D ₁	D ₂
	(mm)	0.78 ± 0.05	1.25 ± 0.05	0.65 ± 0.05	1.50 + 0.10 - 0.00	178.00 ± 1.00	60.00 ± 0.50	13.50 ± 0.20
	(inch)	0.031 ± 0.002	0.049 ± 0.002	0.026 ± 0.002	0.059 + 0.004 - 0.000	7.008 ± 0.039	2.362 ± 0.020	0.531 ± 0.008

0402C (SOD-923F)	SYMBOL	E	F	P	P ₀	P ₁	T	W	W ₁
	(mm)	1.75 ± 0.10	3.50 ± 0.10	4.00 ± 0.10	4.00 ± 0.10	2.00 ± 0.10	0.20 + 0.03 - 0.05	8.00 ± 0.20	12.00 + 0.50 - 0.00
	(inch)	0.069 ± 0.004	0.138 ± 0.004	0.157 ± 0.004	0.157 ± 0.004	0.079 ± 0.004	0.008 + 0.001 - 0.002	0.315 ± 0.008	0.472 + 0.020 - 0.000