

## CEFM101-G Thru. CEFM105-G

Reverse Voltage: 50 to 600 Volts

Forward Current: 1.0 Amp

RoHS Device

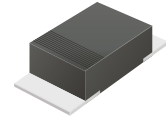

### Features

- Ideal for surface mount applications.
- Easy pick and place.
- Plastic package has Underwriters Lab. flammability classification 94V-0.
- Super fast recovery time for high efficient.
- Built-in strain relief.
- Low forward voltage drop.

### Mechanical data

- Case: Molded plastic, JEDEC SOD-123/Mini SMA.
- Terminals: Solderable per MIL-STD-750, method 2026.
- Polarity: Indicated by cathode band.
- Weight: 0.018 grams approx.

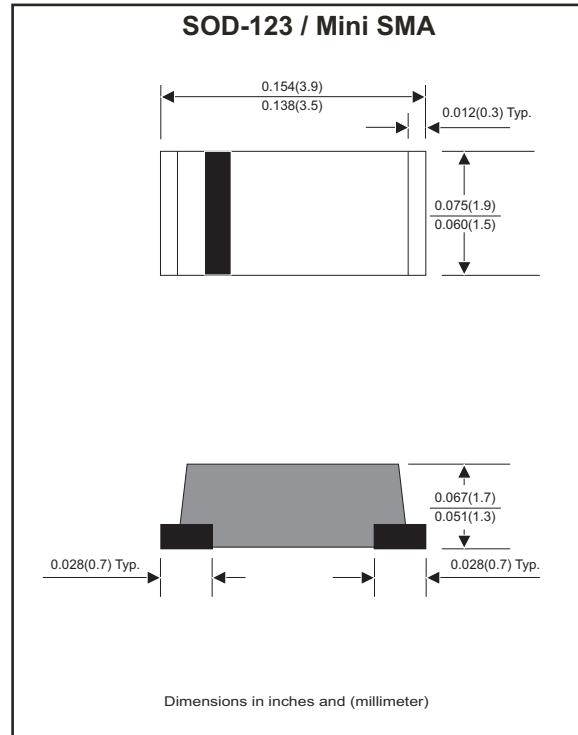

### Maximum Ratings (at TA=25°C unless otherwise noted)

Parameter	Symbol	CEFM 101-G	CEFM 102-G	CEFM 103-G	CEFM 104-G	CEFM 105-G	Unit
Repetitive peak reverse voltage	$V_{RRM}$	50	100	200	400	600	V
Continuous reverse voltage	$V_R$	50	100	200	400	600	V
RMS Voltage	$V_{RMS}$	35	70	140	280	420	V
MAX. Forward surge current	$I_o$	1.0					A
MAX. Forward voltage at $I_F=1.0A$	$V_F$	0.875			1.25	1.75	V
MAX. Forward surge current, 8.3ms single half sine-wave superimposed on rated load (JEDEC method)	$I_{FSM}$	25					A
MAX. Reverse recovery time, (Note 1)	$T_{rr}$	25					nS
MAX. Reverse current	$V_R=V_{RR}$ $T_J=25^\circ C$	5.0					$\mu A$
	$V_R=V_{RR}$ $T_J=125^\circ C$						
TYP. Diode junction capacitance (f=1MHz and applied 4V DC reverse voltage)	$C_J$	15					pF
Operating junction temperature	$T_J$	-55 to +150					$^\circ C$
Storage temperature range	$T_{STG}$	-65 to +175					$^\circ C$

Note 1: Reverse recovery time test Condition,  $I_F=0.5A$ ,  $I_R=1.0A$ ,  $I_{RR}=0.25A$

## Rating and Characteristic Curves (CEFM101-G Thru. CEFM105-G)

Fig.1 - Typical Forward Characteristics

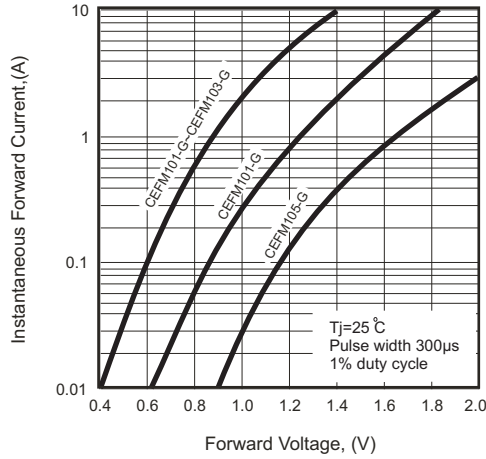

Fig. 2 - Typical Forward Current Derating Curve

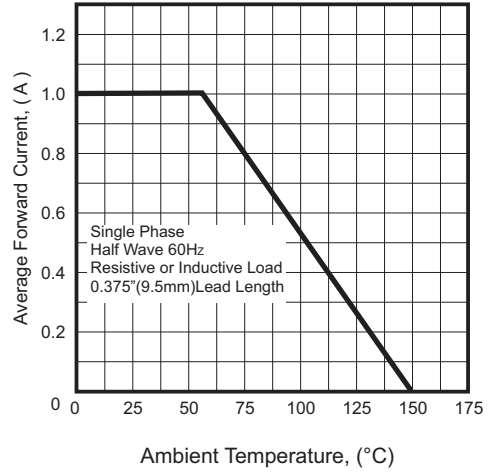
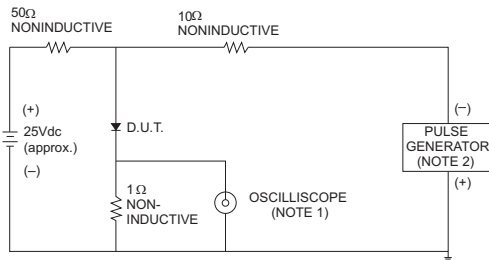

Fig. 3 - Test Circuit Diagram and Reverse Recovery Time Characteristics



NOTES: 1. Rise Time= 7ns max., Input Impedance= 1 megohm.22pF.  
2. Rise Time= 10ns max., Source Impedance= 50 ohms.

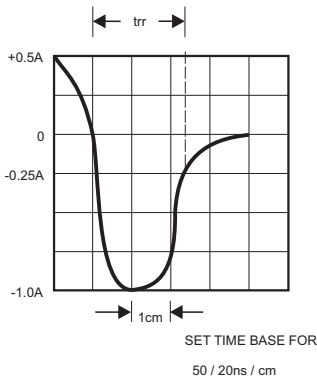

Fig. 4 - Maximum Non-Repetitive Forward Surge Current

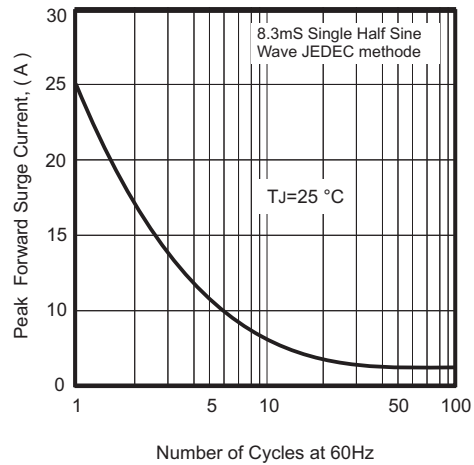
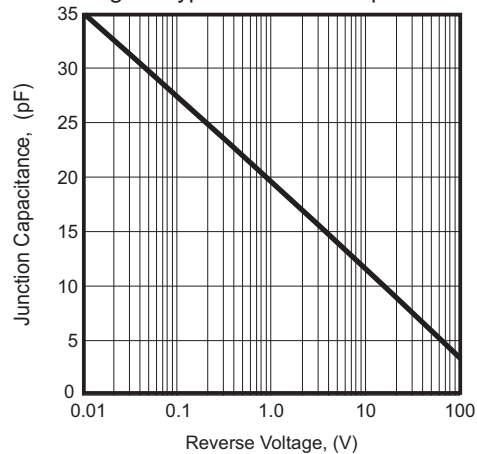
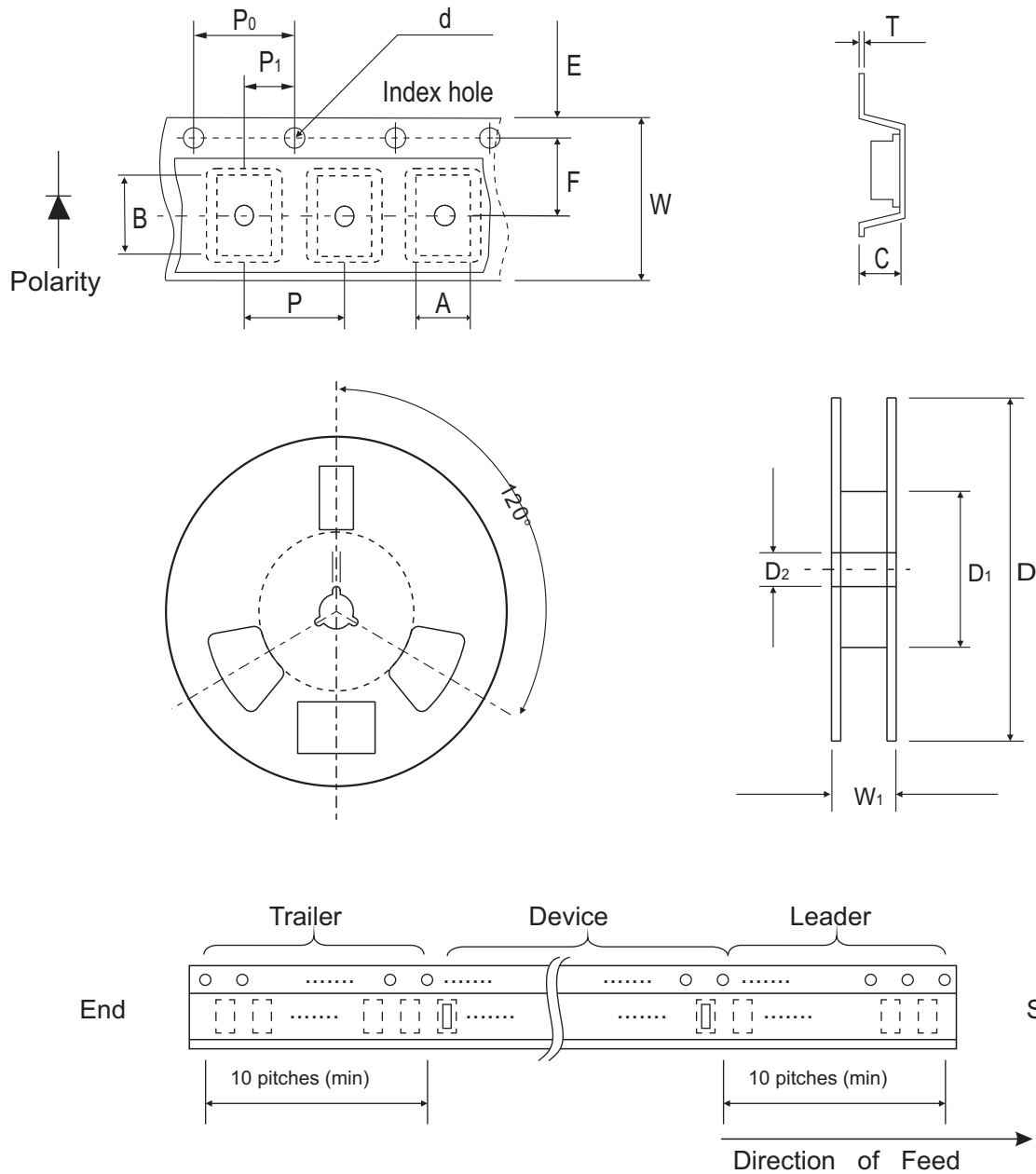

Fig.5 - Typical Junction Capacitance



## Reel Taping Specification



Mini-SMA/SOD-123	SYMBOL	A	B	C	d	D	D1	D2
	(mm)	1.90 ± 0.10	3.90 ± 0.10	1.68 ± 0.10	1.50 ± 0.10	178 ± 2.00	62.0 MIN.	13.0 ± 0.50
	(inch)	0.075 ± 0.04	0.154 ± 0.04	0.066 ± 0.04	0.059 ± 0.004	7.00 ± 0.079	2.440 MIN.	0.512 ± 0.020

Mini-SMA/SOD-123	SYMBOL	E	F	P	P0	P1	T	W	W1
	(mm)	1.75 ± 0.10	3.50 ± 0.10	4.00 ± 0.10	4.00 ± 0.10	2.00 ± 0.10	0.23 ± 0.10	8.00 ± 0.30	11.40 ± 1.0
	(inch)	0.069 ± 0.004	0.138 ± 0.004	0.157 ± 0.004	0.157 ± 0.004	0.079 ± 0.004	0.009 ± 0.004	0.315 ± 0.012	0.449 ± 0.004