

MODEL: CES-503528-28PM-67 | **DESCRIPTION:** SPEAKER**FEATURES**

- 8 ohm rated impedance
- 2.0 W rated power
- IP67 rated

**SPECIFICATIONS**

parameter	conditions/description	min	typ	max	units
input power	max power: IEC-60268-5, filter 60 seconds on, 120 seconds off, 10 cycles (room temp)		2.0	2.5	W
impedance	at 2.0 kHz, 1.0 V	6.8	8	9.2	Ω
resonant frequency (Fo)	at 1.0 V	544	680	816	Hz
frequency response		Fo		20,000	Hz
sound pressure level	at 2.0 W, 10 cm, avg at 2.0 kHz	94	97	100	dB
distortion	at 2.0 kHz, rated power, 10 cm			10	%
buzz, rattle, etc.	must be normal at sine wave, frequency range			4.0	V
polarity	cone moves forward w/ positive dc current to "+" terminal				
dimensions	50.0 x 35.0 x 27.8				mm
magnet	Nd-Fe-B				
enclosure material	ABS				
cone material	PEI				
terminal	wire leads with connector				
weight			21.0		g
operating temperature		-20		55	$^{\circ}$ C
storage temperature		-30		60	$^{\circ}$ C
RoHS	yes				
IP level	IP67 (front side)				

Notes: 1. All specifications measured at 25~75 $^{\circ}$ C, humidity at 45~85%, under 86~106 kPa pressure, unless otherwise noted.

MECHANICAL DRAWING

units: mm
tolerance: ± 0.5 mm

wire: UL1571 30 AWG
internal speaker: CMS-305-158SP-67
connector: Molex 51021-0200 or equivalent; P=1.25

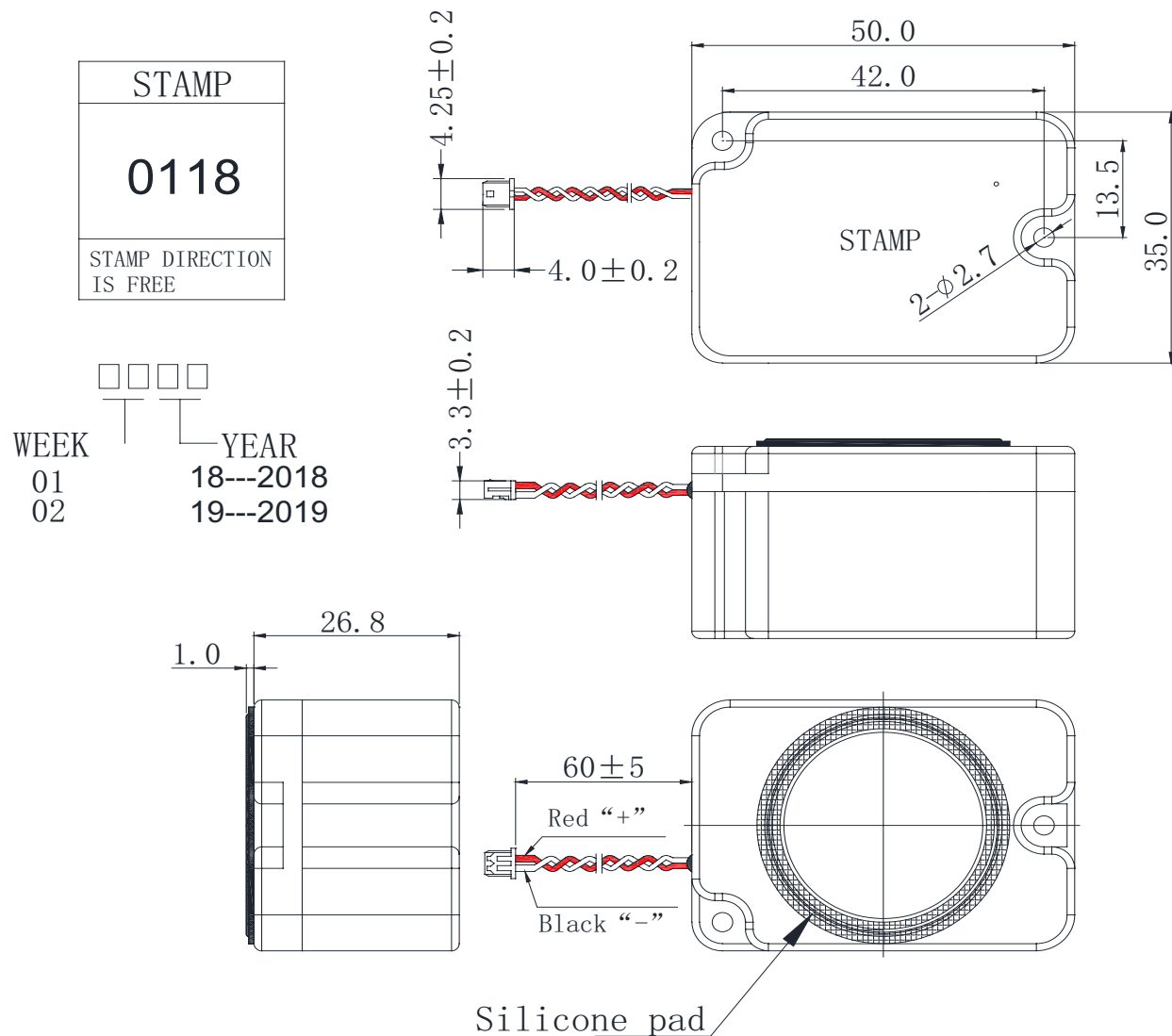

RESPONSE CURVES

Frequency Response Curve

Test Conditions: 2.0 W / 10 cm

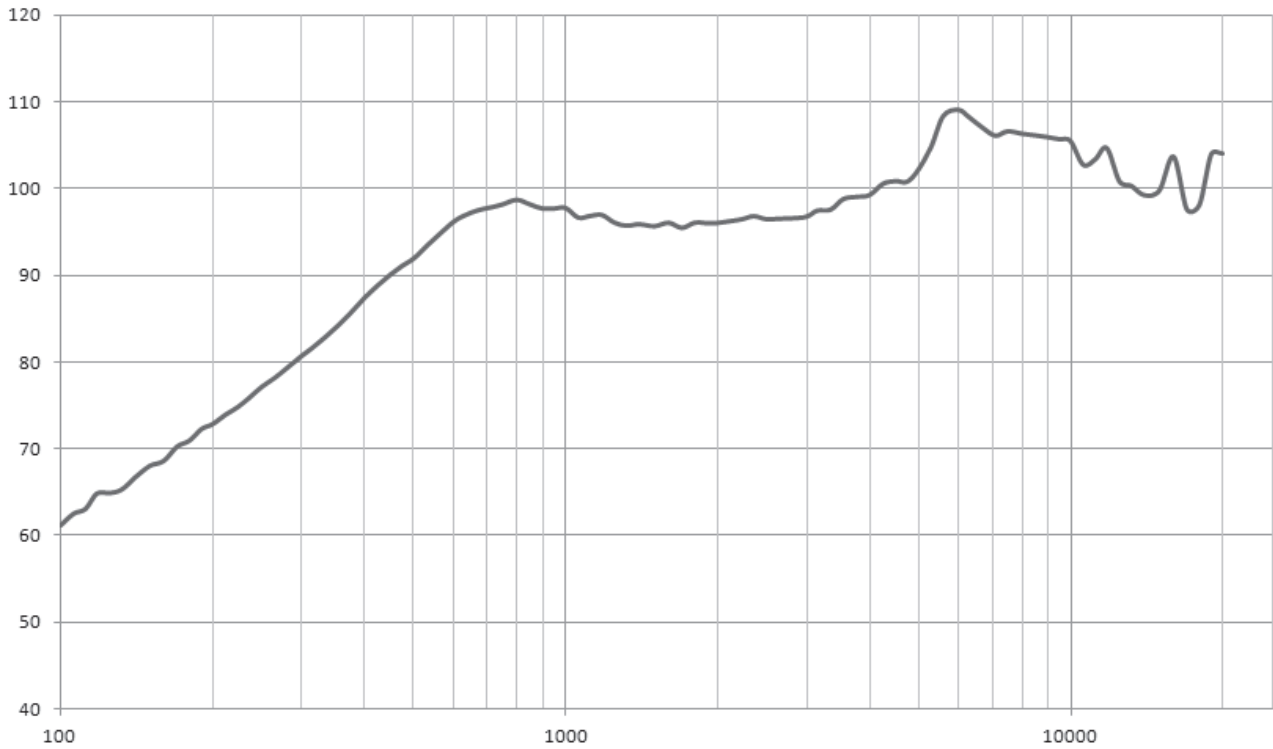

Total Harmonic Distortion Curve

Test Conditions: 2.0 W / 10 cm

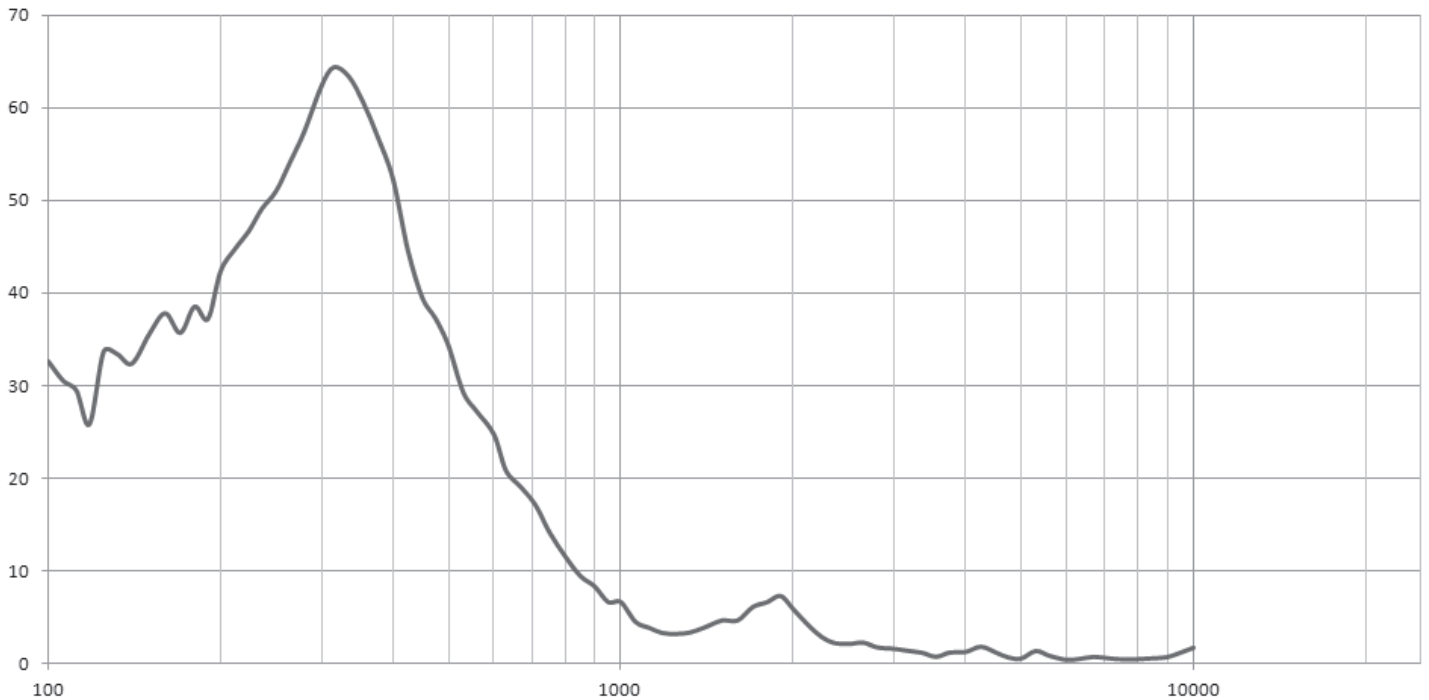

PACKAGING

units: mm

Tray Size: 430 x 430 x 40 mm
 Tray QTY: 45 pcs per tray
 Carton Size: 460 x 460 x 430 mm
 Carton QTY: 450 pcs per carton

