



CFD69716P



CFD69716P1

U.S. Patent 10,680,339

The CFD 5G two-port MIMO DAS antennas series is the latest addition to Laird Connectivity's extensive DAS antenna portfolio. They extend the current frequency offering up to 7125 MHz to service more of the available 5G frequency bands. Mounting options include hard and ceiling tile mounting and with or without screw holes for additional security.

These antennas are applicable for environments where aesthetics and wide-angle coverage are necessary for successful wireless deployment. Their surprisingly small size and ultra-low-profile enables maximum mounting flexibility while maintaining desired in-building aesthetics.

CFD 5G series antennas support 698-960, 1350-1550, 1690-4200, and 5150-7125 MHz in an ultra-low-profile format that is discrete and unobtrusive.

FEATURES AND BENEFITS

- Full coverage – Wide frequency coverage
- Performance – VSWR ratings of <1.7:1 up to 4200 MHz
- Low PIM – Rated to 4200 MHz with an impressive -162 dBc
- MIMO – Two-port MIMO for multipath mitigation
- Versatile – Mounting options for ceiling tile or hard ceilings
- Quality – Designed and built to exacting specifications
- Peace of mind – Backed by our five-year warranty

APPLICATIONS

- Arenas/airports/campuses
- Office buildings
- Hospitals
- Large residential buildings
- Hotels and casinos
- Public safety



ELECTRICAL SPECIFICATIONS

Model Name	CFD69716P / CFD69716P1											
Number of Ports	2											
Operating Frequency (MHz)	698-824	824-894	880-960	1350-1550	1690-1880	1850-1990	1910-2180	2300-2700	3300-3800	3800-4200	5150-5925	5925-7125
Peak Gain – Average (dBi)	2.8	2.4	2.3	4.0	3.1	3.0	4.5	4.6	5.1	4.9	4.7	4.6
Peak Gain (dBi)	3.3	2.8	2.7	4.3	3.4	3.8	5.7	5.4	5.5	5.3	5.6	5.4
VSWR – Avg	1.5		1.2		1.5			1.6	1.4		1.7	
VSWR – Max	1.7:1											2.3:1
PIM - 2x20W (dBc) (Max)	-150		-		-			-150		-		
PIM – 2x20W (dBc) (Average)	-160		-		-			-162		-		
Isolation, Max (dB)	15		14		15			25				
Isolation, Avg (dB)	21		16		20			34		38		
Ports	2											
Nominal Impedance (Ω)	50											
Polarization	Linear – Horizontal											
Azimuth Beam Width (°)	360, Omnidirectional											
Max Power - Ambient 25°C (W)	50 (698-4200 MHz) / 10 (5150-7125 MHz)											

MECHANICAL SPECIFICATIONS

Dimensions – H x D – mm (in.)	7.6 x 250 (0.30 x 9.84)
Weight – g (oz.)	420 (14.82)
Antenna Color	White
Radome Material	PC, UL94-V0

ENVIRONMENTAL SPECIFICATIONS

Operating Environment (Indoor or Outdoor)	Indoor
Operating Temperature – °C (°F)	-30 to +70°C (-22 to +158°F)
Storage Temperature – °C (°F)	-40 to +85°C (-40 to +185°F)
Material Substance Compliance	RoHS

CONFIGURATION

PART NUMBER	CABLE LENGTH	CONNECTOR	MOUNTING	PACKAGING
CFD69716P-30D43F	30 cm (12")	4.3-10 FEMALE	CEILING TILE	UNIT
CFD69716P-30NF	30 cm (12")	N TYPE - FEMALE	CEILING TILE	UNIT
CFD69716P-B30D43F	30 cm (12")	4.3-10 FEMALE	CEILING TILE	BULK
CFD69716P-B30NF	30 cm (12")	N TYPE - FEMALE	CEILING TILE	BULK
CFD69716P1-30D43F	30 cm (12")	4.3-10 FEMALE	HARD CEILING	UNIT
CFD69716P1-30NF	30 cm (12")	N TYPE - FEMALE	HARD CEILING	UNIT
CFD69716P1-B30D43F	30 cm (12")	4.3-10 FEMALE	HARD CEILING	BULK
CFD69716P1-B30NF	30 cm (12")	N TYPE - FEMALE	HARD CEILING	BULK

MECHANICAL DRAWING

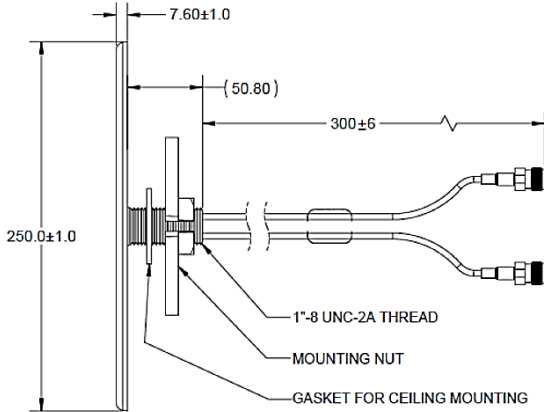

Figure 1: CFD69716P

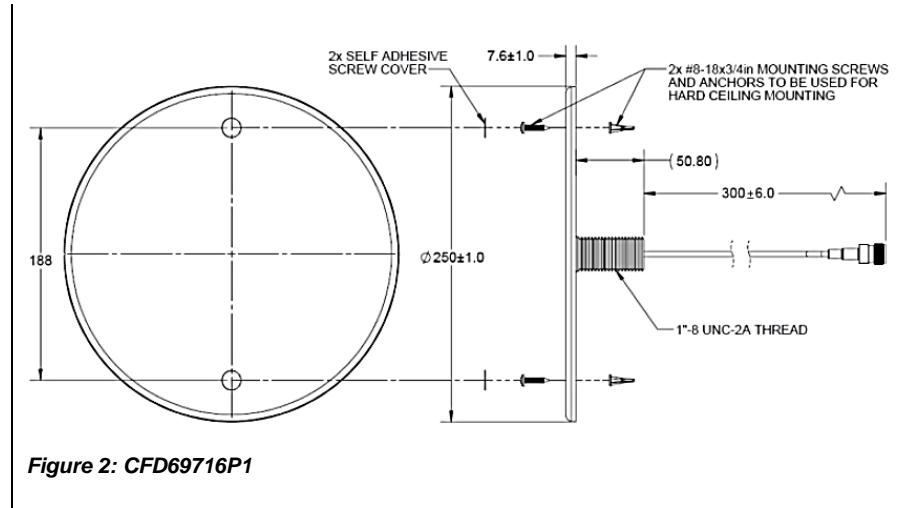
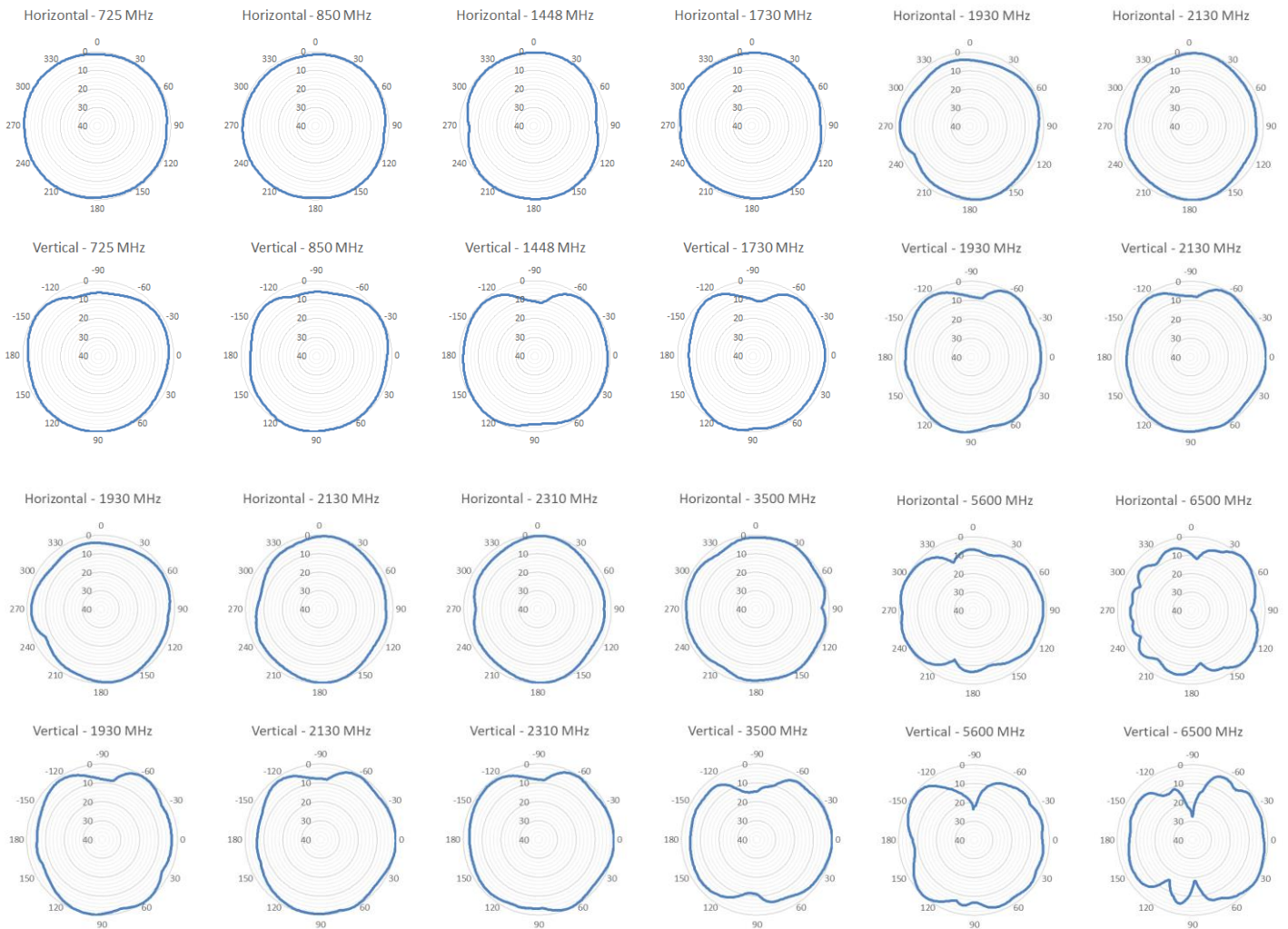

Figure 2: CFD69716P1

RADIATION PATTERNS



Note: 1. Horizontal plane cut is based on Theta=45° Plane from the measurement coordinate system

2. The radiation pattern presented is normalized combining diversity coverage for two ports gain.