

SERIES: CFM-50 | **DESCRIPTION:** DC AXIAL FAN

FEATURES

- 50 x 50 mm frame
- high fan speed for greater air flow
- dual ball bearing construction
- auto restart protection standard on all models



MODEL	input voltage		input current		input power	rated speed	air flow ¹	static pressure ²	noise
	rated [Vdc]	range [Vdc]	typ [A]	max [A]	max [W]	typ [RPM]	[CFM]	[inch H ₂ O]	max [dBA]
CFM-5010-03*	5	4~5.75	0.21	0.28	1.4	6,100	16.07	0.20	37.2
CFM-5010-13*	12	6~13.8	0.11	0.14	1.68	6,100	16.07	0.20	37.0

Notes: 1. At 0 inch H₂O static pressure.
 2. At 0 CFM airflow.
 *. Discontinued CFM-5010-03-20 & CFM-5010-13-20 models.

PART NUMBER KEY

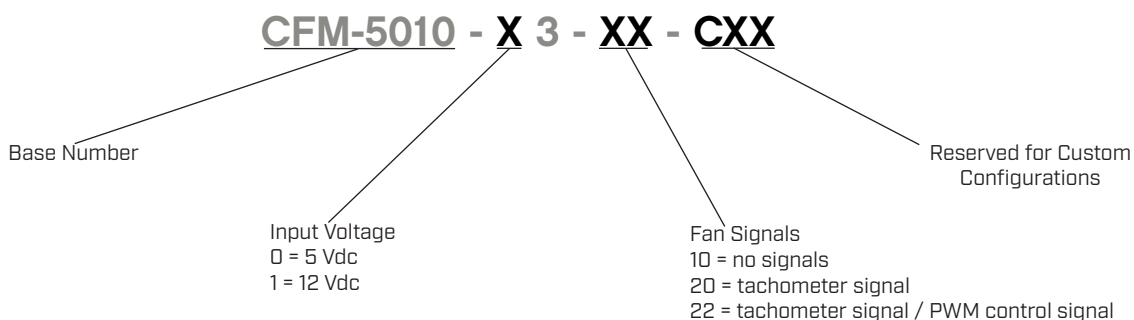

INPUT

parameter	conditions/description	min	typ	max	units
operating input voltage	5 Vdc input models	4	5	5.75	Vdc
	12 Vdc input models	6	12	13.8	Vdc
current	5 Vdc input models		0.21	0.28	A
	12 Vdc input models		0.11	0.14	A
power	5 Vdc input models		1.05	1.4	W
	12 Vdc input models		1.32	1.68	W
starting voltage	at 25°C				
	5 Vdc input models		4		Vdc
	12 Vdc input models		6		Vdc

PERFORMANCE

parameter	conditions/description	min	typ	max	units
rated speed	at 25°C, after 10 minutes	5,490	6,100	6,710	RPM
air flow	at 0 inch H ₂ O, see performance curves		16.07		CFM
static pressure	at 0 CFM, see performance curves		0.20		inch H ₂ O
noise	at 1 m				
	5 Vdc input models		36.0	37.2	dBA
	12 Vdc input models		36.0	37.0	dBA

PROTECTIONS / SIGNALS¹

parameter	conditions/description	min	typ	max	units
auto restart protection	available on all models				
tachometer signal	available on "20" and "22" models				
PWM control signal	available on "22" models				

Notes: 1. See application notes for details.

SAFETY & COMPLIANCE

parameter	conditions/description	min	typ	max	units
insulation resistance of frame	at 500 Vdc between frame and positive terminal	10			MΩ
dielectric strength	at 500 Vac, 60 Hz, 1 minute between frame and positive terminal			5	mA
safety approvals	UL/cUL 507, TUV (EN 62368-1)				
EMI/EMC	EN 55022:2010+AC:2011 Class B, EN 61000-3-2:2014, EN 61000-3-3:2013, EN 55024:2010				
life expectancy	at 45°C, 15-65% RH		70,000		hours
RoHS	yes				

ENVIRONMENTAL

parameter	conditions/description	min	typ	max	units
operating temperature		-10		70	°C
storage temperature		-40		70	°C
operating humidity	non-condensing	5		90	%
storage humidity	non-condensing	5		95	%

PERFORMANCE CURVES

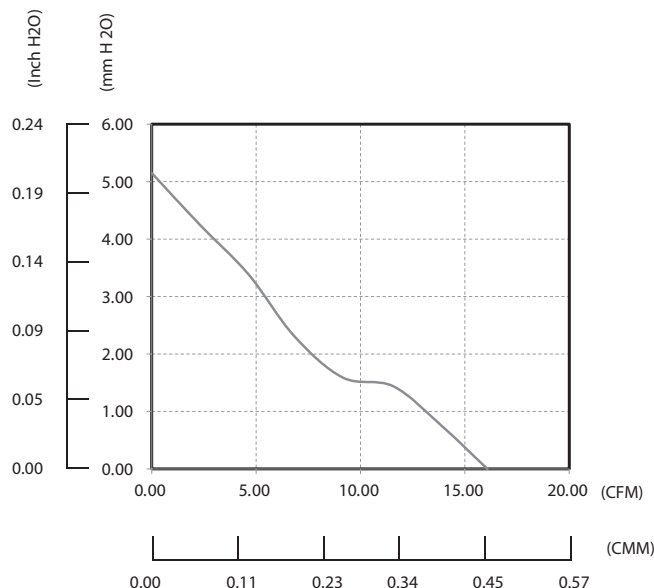

MECHANICAL

parameter	conditions/description	min	typ	max	units
motor	4 pole DC brushless				
bearing system	ball bearing				
direction of rotation	counter-clockwise viewed from front of fan blade				
dimensions	50 x 50 x 10.6				mm
material	PBT (UL94V-0)				
weight	5 Vdc input models		20.7		g
	12 Vdc input models		20.3		g

MECHANICAL DRAWING

units: mm [inch]

wire: UL 1061, 28 AWG

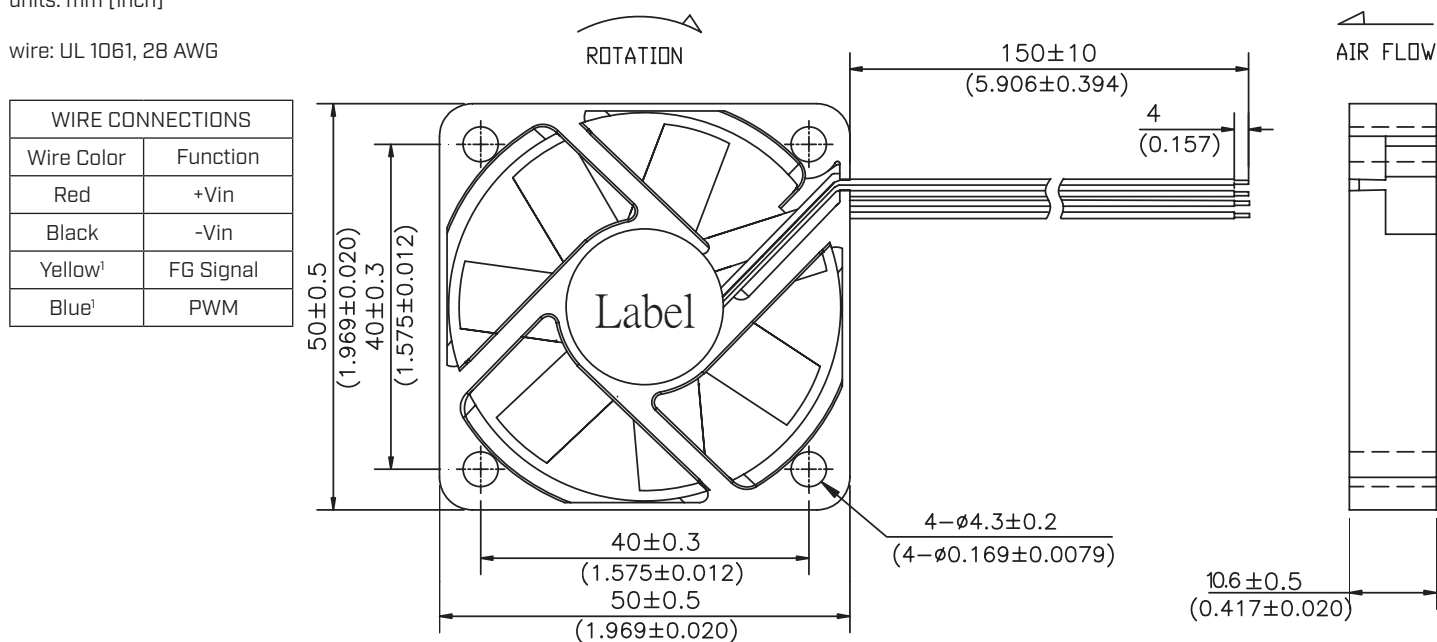

Note: 1. Wires only present on versions with output signals.

APPLICATION NOTES

Auto Restart Protection/Current Limit Protection

When the fan motor is locked, the device will cut off the drive current within two to six seconds and restart automatically after a few seconds. If the lock situation is continued, the device will work on a repeated cycle of cut-off and restart until the lock is released. [See Figure 1 below].

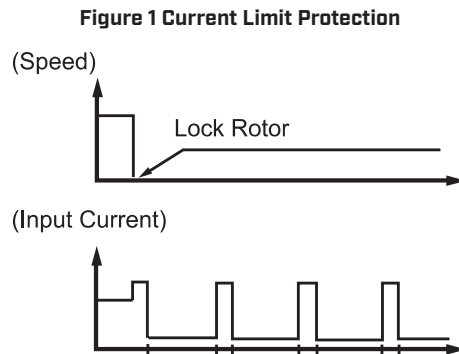

Pulse Sensor/Tachometer Signal/FG

Pulse Sensor is for detecting the rotational speed of the fan motor. At locked rotor condition, the signal stops cycling and the output is fixed at VoH or VoL [See Figures 2~3 below].

Figure 2 Output Waveform

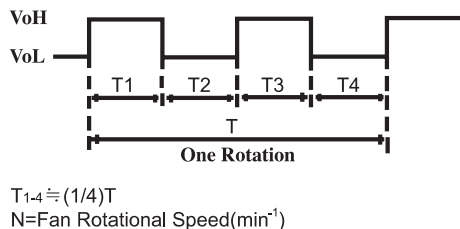
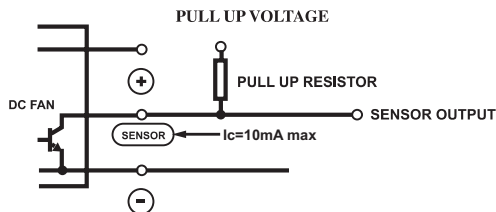

Figure 3 FG Signal Output Circuit: Open Collector



PMW Control Signal

A speed control lead can be provided that will accept a PWM signal from the customer circuit to vary the speed of the fan. The change in speed is linear by changing the Duty-Cycle of the PWM. Open collector type and pull-up voltage is changed by maximum operating voltage and sink current by consuming current. [See Figure 4 below].

Figure 4 Duty Cycle

