

SERIES: CFM-80BF | **DESCRIPTION:** DC AXIAL FAN**FEATURES**

- dual ball bearing system
- 80 x 80 mm frame
- multiple speed options
- tachometer signal available



MODEL	input voltage		input current ¹	input power ¹	rated speed ¹	airflow ²	static pressure ³	noise ⁴
	rated (Vdc)	range (Vdc)	max (A)	max (W)	typ (RPM±10%)	(CFM)	(inch H ₂ O)	typ (dBA)
CFM-8015BF-120-213	12	10.8~13.2	0.09	1.08	2,000 ⁵	23.23	0.04	21.3
CFM-8015BF-130-301	12	10.8~13.2	0.26	3.12	3,000 ⁵	34.85	0.10	30.1
CFM-8015BF-140-363	12	10.8~13.2	0.45	5.40	4,000	46.47	0.18	36.3
CFM-8015BF-220-213	24	21.6~26.4	0.06	1.44	2,000 ⁵	23.23	0.04	21.3
CFM-8015BF-230-301	24	21.6~26.4	0.21	5.04	3,000 ⁵	34.85	0.10	30.1
CFM-8015BF-240-363	24	21.6~26.4	0.21	5.04	4,000	46.47	0.18	36.3
CFM-8020BF-125-273	12	10.8~13.2	0.08	0.96	2,500 ⁵	24.52	0.07	27.4
CFM-8020BF-135-346	12	10.8~13.2	0.15	1.80	3,500	34.33	0.14	34.7
CFM-8020BF-145-401	12	10.8~13.2	0.30	3.60	4,500	44.14	0.24	40.2
CFM-8020BF-155-444	12	10.8~13.2	0.45	5.40	5,500	53.94	0.35	44.5
CFM-8020BF-225-273	24	21.6~26.4	0.05	1.20	2,500 ⁵	24.52	0.07	27.4
CFM-8020BF-235-346	24	21.6~26.4	0.09	2.16	3,500	34.33	0.14	34.0
CFM-8020BF-245-401	24	21.6~26.4	0.18	4.32	4,500	44.14	0.24	40.2
CFM-8020BF-255-444	24	21.6~26.4	0.27	6.48	5,500	53.94	0.35	44.5

- Notes:
1. At rated voltage, after 3 minutes.
 2. At rated voltage, room temperature, 65% humidity, 0 inch H₂O static pressure.
 3. At rated voltage, 0 CFM airflow.
 4. Measured in an anechoic chamber as per ISO3745/GB4214-84 at rated voltage, with background noise 20±2 dBA at 1 m from the fan intake.
 5. Typical rated speed is measured as RPM±350 at rated voltage.
 6. All specifications are measured at 25°C, 65% relative humidity unless otherwise specified.

PART NUMBER KEY

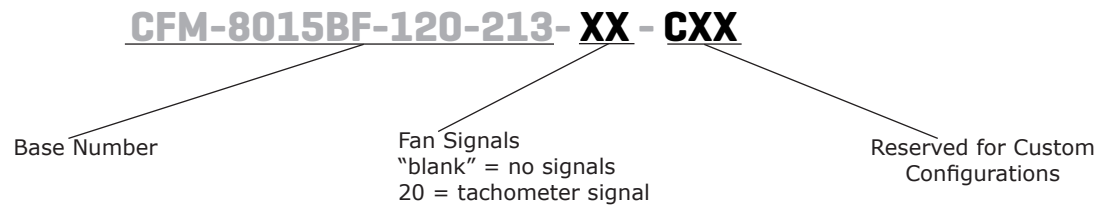

INPUT

parameter	conditions/description	min	typ	max	units
operating input voltage ⁷	12 Vdc input models	10.8	12	13.2	Vdc
	24 Vdc input models	21.6	24	26.4	Vdc
starting voltage	12 Vdc input models		7		Vdc
	24 Vdc input models (CFM-8020BF-225-273 & CFM-8020BF-235-346: 12 Vdc)		14		Vdc

Note: 7. See Model section on page 1 for specific input voltage ranges.

PERFORMANCE⁸

parameter	conditions/description	min	typ	max	units
rated speed	at rated voltage, 25°C, after 3 minutes	2,000		5,500	RPM
air flow	at 0 inch H ₂ O, see performance curves	23.23		53.94	CFM
static pressure	at 0 CFM, see performance curves	0.04		0.35	inch H ₂ O
noise	at 1 m, rated speed	21.3		44.5	dBA

Note: 8. See Model section on page 1 for specific values.

PROTECTIONS / FEATURES⁹

parameter	conditions/description	min	typ	max	units
auto restart	on all models				
polarity protection	on all models				
tachometer signal	available on "20" models				

Notes: 9. See Application Notes for details.

SAFETY & COMPLIANCE

parameter	conditions/description	min	typ	max	units
insulation resistance	at 500 Vdc between frame and positive terminal	10			MΩ
dielectric strength	at 500 Vac, 60 Hz, 1 minute between housing and positive terminal			5	mA
safety approvals	UL/cUL 507, TUV (EN/IEC 62368-1:2020+A11)				
EMI/EMC	EN 55032:2015, EN 55035:2017				
life expectancy	at 40°C, 65% RH, 90% confidence level		70,000		hours
RoHS	yes				

ENVIRONMENTAL

parameter	conditions/description	min	typ	max	units
operating temperature		-10		70	°C
storage temperature		-40		75	°C
operating humidity	non-condensing	35		85	%
storage humidity	non-condensing	35		85	%

PERFORMANCE CURVES

CFM-8015BF-120-213

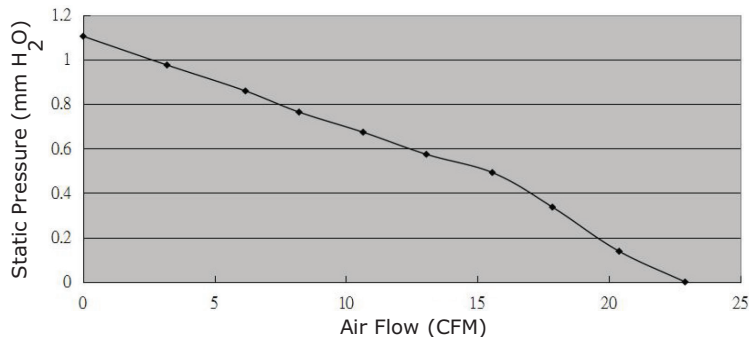

CFM-8015BF-130-301

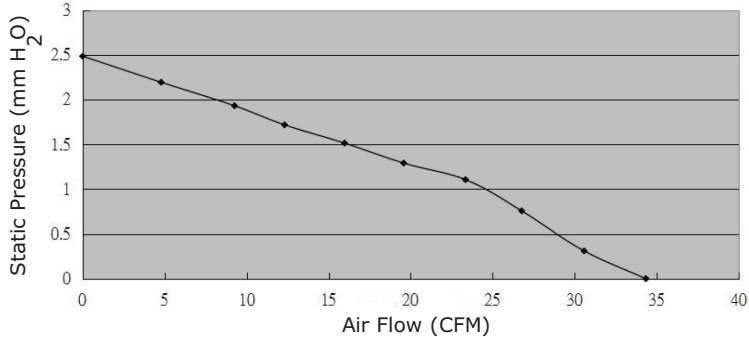

CFM-8015BF-140-363

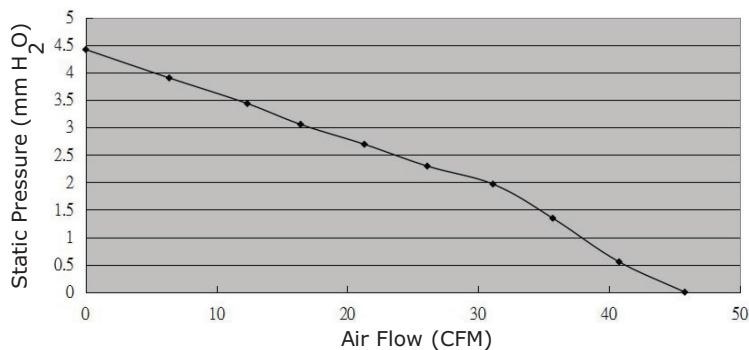

CFM-8015BF-220-213

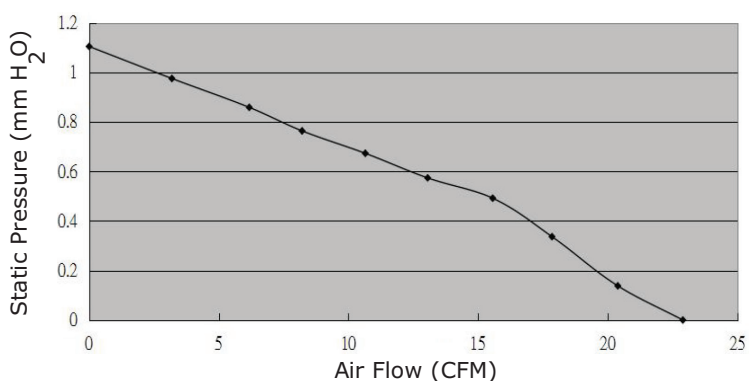

CFM-8015BF-230-301

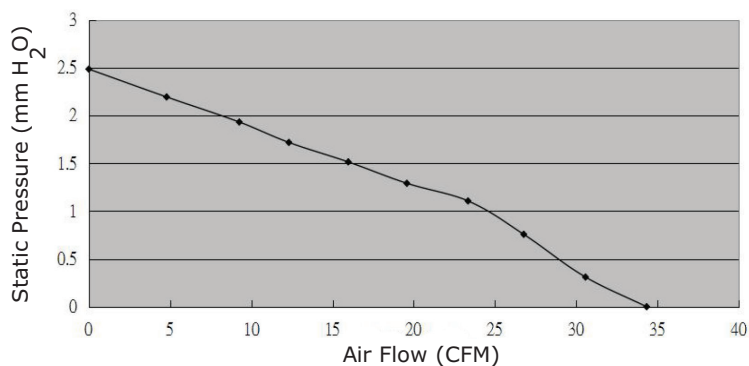

CFM-8015BF-240-363

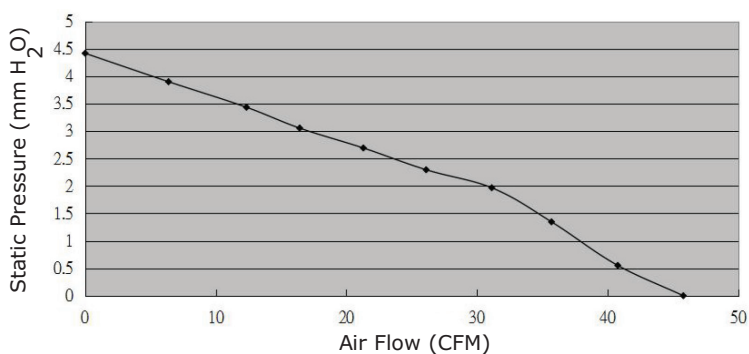

PERFORMANCE CURVES (CONTINUED)

CFM-8020BF-125-273

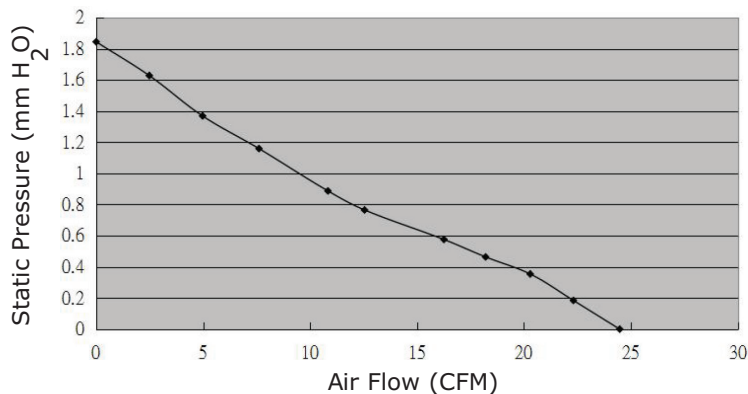

CFM-8020BF-135-346

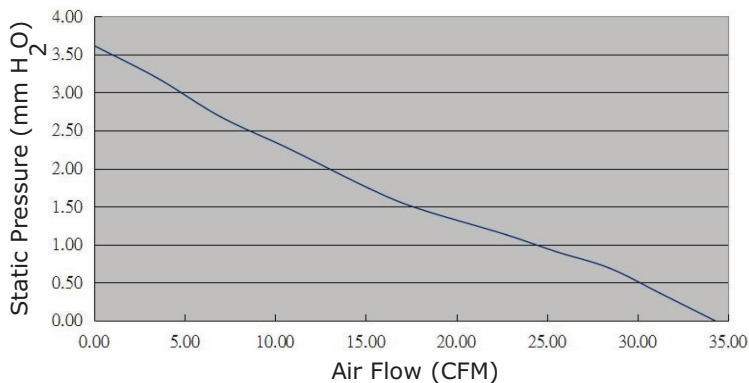

CFM-8020BF-145-401

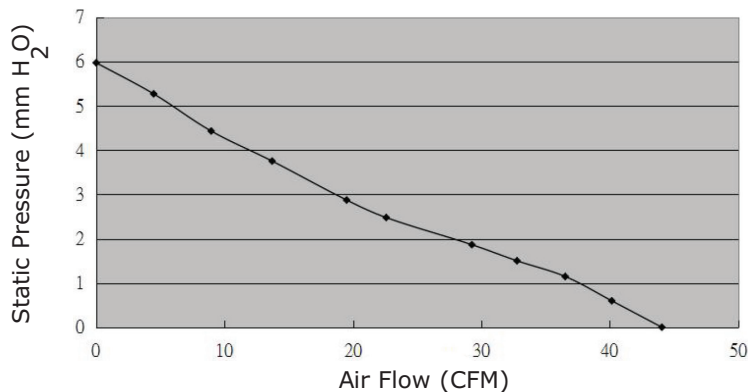

CFM-8020BF-155-444

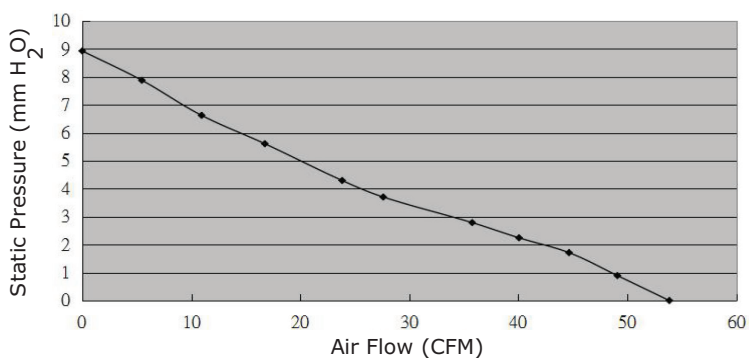

CFM-8020BF-225-273

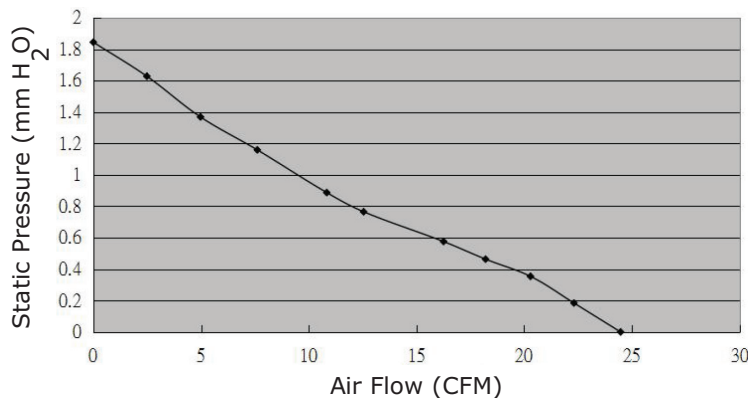

CFM-8020BF-235-346

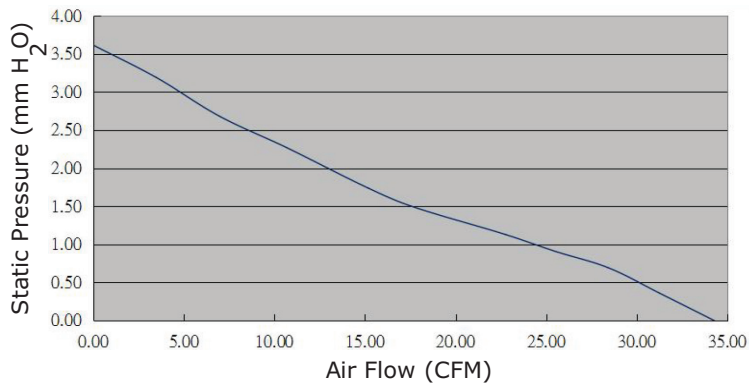

PERFORMANCE CURVES (CONTINUED)

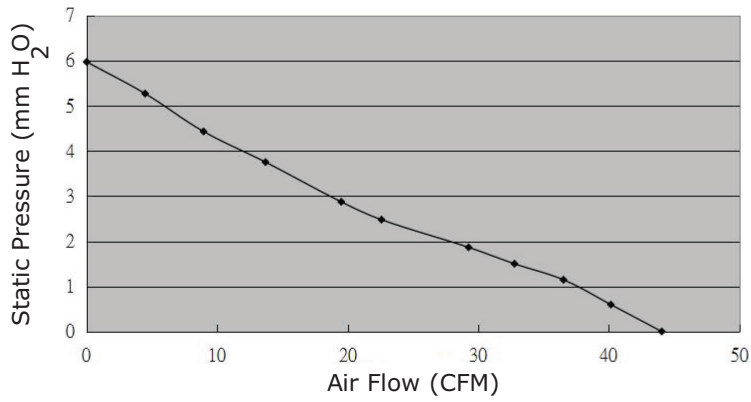
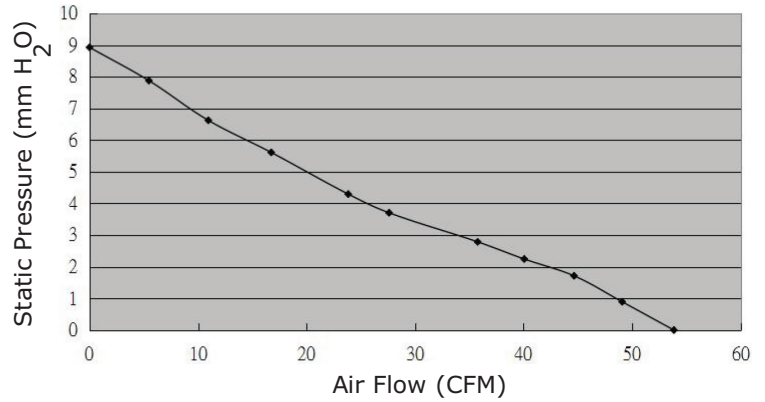
CFM-8020BF-245-401**CFM-8020BF-255-444**

MECHANICAL

parameter	conditions/description	min	typ	max	units
motor	4 pole DC brushless				
bearing system	dual ball bearing				
direction of rotation	counter-clockwise viewed from front of fan blade				
dimensions	CFM-8015BF models: 80 x 80 x 15.4 CFM-8020BF models: 80 x 80 x 20.0				mm mm
material	PBT (UL94V-0)				
weight	CFM-8015BF models: weight varies by model CFM-8020BF models: weight varies by model	50.8 55.1		55.1 61.0	g g

MECHANICAL DRAWING

units: mm

wire: UL 1007, 26 AWG

MOUNTING SCREW (Pan Head)			
Screw Type	Size	Standard	Torque
Machine Screw	M4	JIS B1111-1974	7.5 kgf-cm
Self-tapping Screw	M5	JIS B1122 Type 2	7.5 kgf-cm

CFM-8015BF

WIRE CONNECTIONS	
Wire Color	Function
Red	+Vin
Black	-Vin
Yellow ¹⁰	Tach Signal

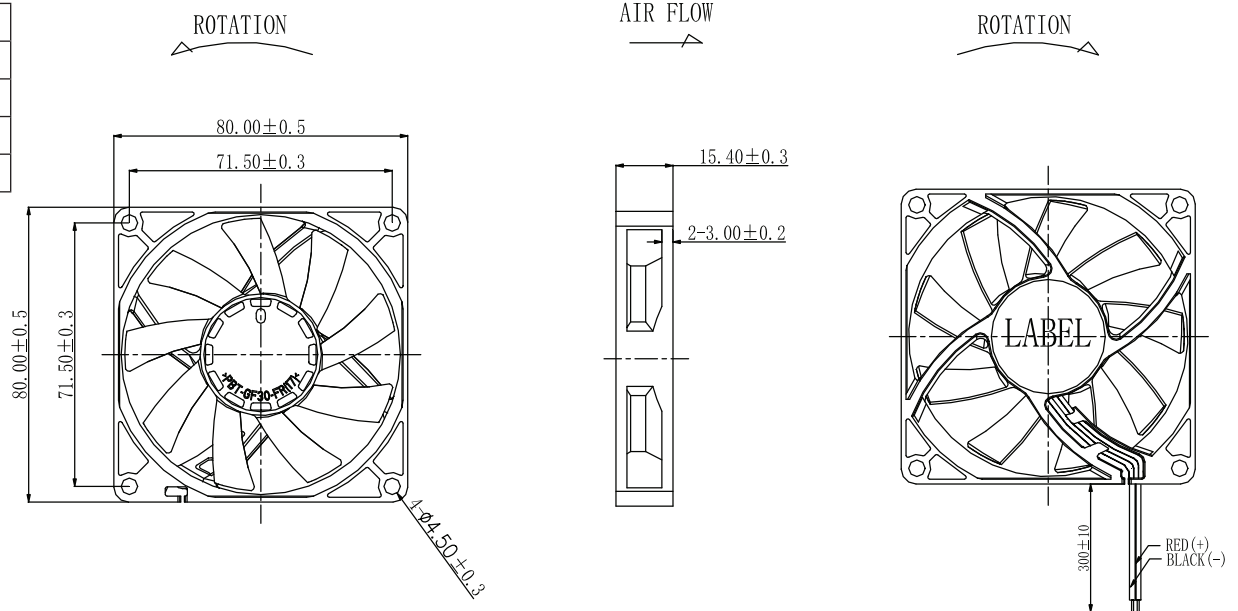

Notes: 10. Wires only present on versions with output signals.

MECHANICAL DRAWING (CONTINUED)

units: mm

wire: UL 1007, 24 AWG

MOUNTING SCREW (Pan Head)			
Screw Type	Size	Standard	Torque
Machine Screw	M4	JIS B1111-1974	4.5 kgf-cm
Self-tapping Screw	M4.8	JIS B1122 Type 2	5.5 kgf-cm

CFM-8020BF

WIRE CONNECTIONS	
Wire Color	Function
Red	+Vin
Black	-Vin
Yellow ¹⁰	Tach Signal

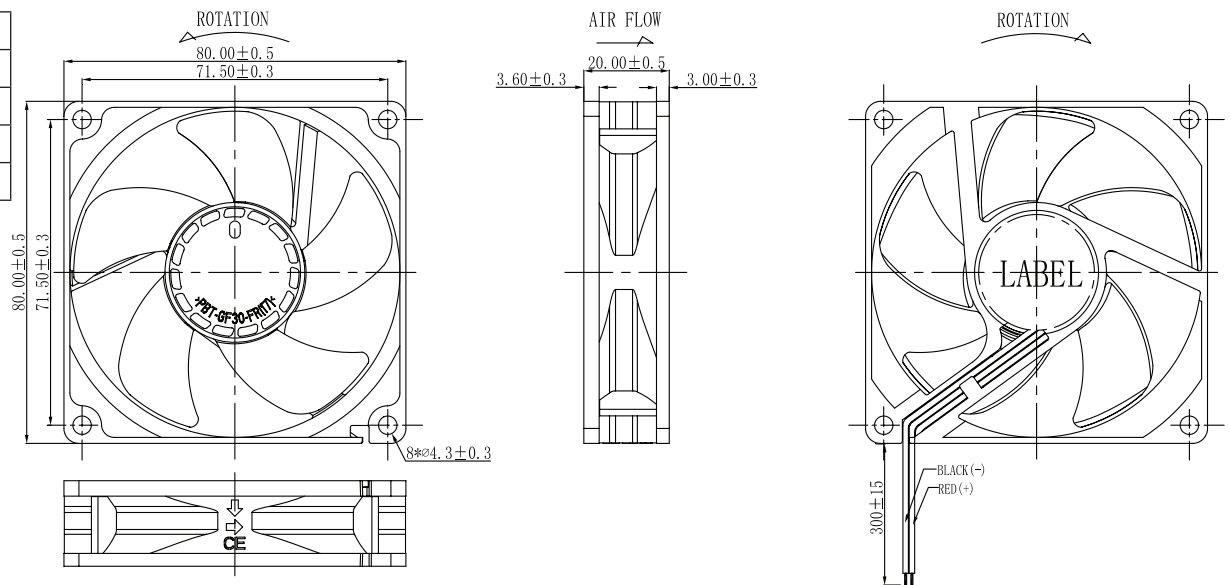

Notes: 10. Wires only present on versions with output signals.

APPLICATION NOTES

Auto Restart Protection

When the fan motor is locked by an external force, the device will temporarily turn off electrical power to the motor and restart automatically when the locked rotor condition is released.

Polarity Protection

Able to withstand 10 minutes of reverse polarity connection between the positive and negative wires without causing damage.

Tachometer Signal (Yellow Wire)

The tachometer signal is for detecting the rotational speed of the fan motor. The output will be a square wave when fan is operating and V_{FG} or V_{CE} depending on the locked rotor position when fan motor is locked (See Figures 1~2 below).

Figure 1: Tachometer Output Circuit

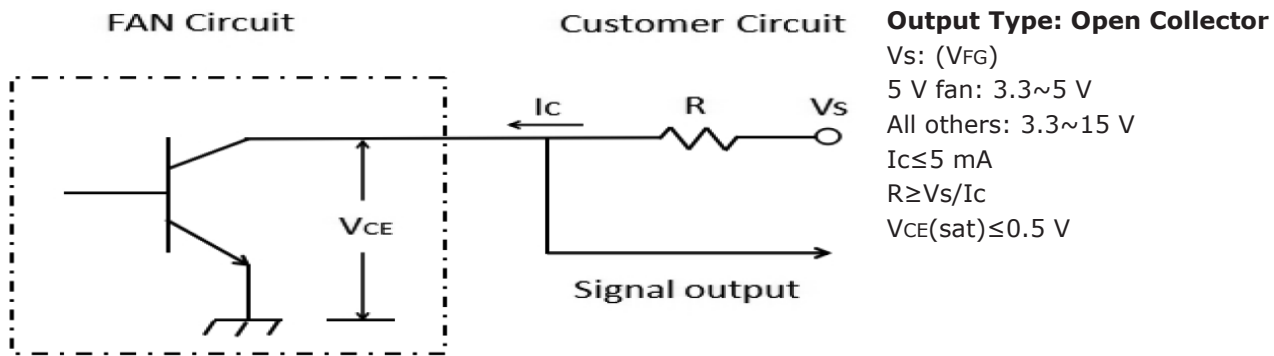

Figure 2: Tachometer Output Waveform

