

CG5 and SL0902A Series

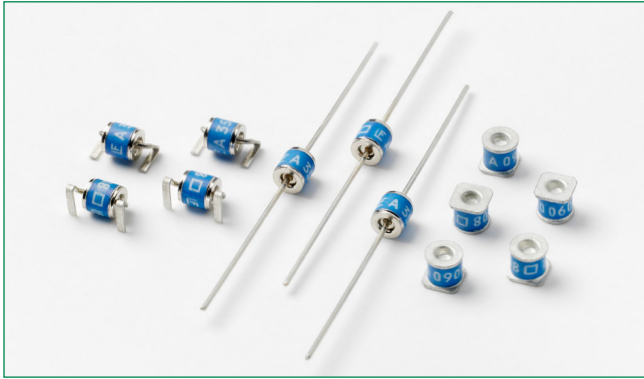

Agency Approvals

| Agency | Agency File Number |
|--------|--------------------|
| | E128662 |

2 Electrode GDT Graphical Symbol

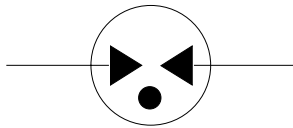

Additional Information



Datasheet
CG5 Series



Resources
CG5 Series



Samples
CG5 Series



Datasheet
SL0902A



Resources
SL0902A



Samples
SL0902A

Description

Littelfuse Broadband Optimized™ SL0902A Series offers high surge ratings in a miniature package. Special design features provide high levels of protection against fast rising transients in the 100V/μs to 1kV/μs range usually caused by lightning disturbances. Low insertion loss is perfectly suited to broadband equipment applications. The capacitance does not vary with voltage, and will not cause operational problems with ADSL2+, where capacitance variation across Tip and Ring is undesirable. These devices are extremely robust and are able to divert a 2500A pulse without destruction. For AC Power Cross of long duration, overcurrent protection is recommended.

Littelfuse CG5 MS mini surge arresters are specifically designed for protection of electrical and communication equipment against over voltage transients in surface mount assembly applications. This series offers the most cutting edge protection using non-radioactive elements.

Features

- RoHS compliant and Lead-free
- GHz working frequency
- Excellent stability on multiple pulse duty cycle
- Excellent response to fast rising transients.
- Ultra Low Insertion Loss
- 5KA surge capability tested with 8/20μS pulse as defined by IEC 61000-4-5, 2nd edition
- Ultra small devices offered in a variety of mounting lead forms
- Non-Radioactive
- Low capacitance (<1pF)
- Voltage Ranges 90V to 600V
- UL Recognized
- Conforms to ITU-T K12, IEC 61000-4-5, 2nd edition

Applications

- Communication equipment
- CATV equipment
- Test equipment
- Data lines
- Power supplies
- Telecom SLIC protection
- Broadband equipment
- ADSL equipment, including ADSL2+
- XDSL equipment
- Satellite and CATV equipment
- General telecom equipment

Electrical Characteristics

| Part Number | Device Specifications (at 25°C) | | | | | | Life Ratings | | | | | |
|----------------------|---------------------------------|-----|-----|---------------------------------------|---|------------------------------|---------------------|------------------------|--|---|--------------------------------------|--|
| | DC Breakdown in Volts (@100V/s) | | | Impulse Breakdown in Volts (@100V/μs) | Impulse Breakdown In Volts (@1 Kv/μsec) | Insulation Resistance | Capacitance (@1MHz) | Surge Life (10/1000μs) | Nominal Impulse Discharge Current (8/20μs) | Nominal AC Discharge Current (10x1sec @50-60Hz) | AC Discharge Current (9 cycle @50Hz) | Max Impulse Discharge Current (1 Application @ 10/350μs) |
| | MIN | TYP | MAX | MAX | | MIN | MAX | | | | | |
| SL0902A090 CG590 | 72 | 90 | 108 | 550 | 700 | 10 ¹⁰ Ω (at 50V) | 1.5 pf | 300 shots (@100A) | 10 shots (@5kA) | 5 A | 10 A | 0.5kA |
| CG5145 | 116 | 145 | 174 | 550 | 650 | | | | | | | |
| CG5150 | 120 | 150 | 180 | 550 | - | | | | | | | |
| SL0902A230 CG5230 | 184 | 230 | 276 | 550 | 650 | | | | | | | |
| CG5250 | 200 | 250 | 300 | 600 | - | | | | | | | |
| CG5270* | 216 | 270 | 324 | 650 | - | | | | | | | |
| SL0902A350 CG5350 | 280 | 350 | 420 | 800 | 900 | | | | | | | |
| CG5400 | 320 | 400 | 480 | 900 | - | | | | | | | |
| SL0902A420* | 336 | 420 | 504 | 900 | 1000 | | | | | | | |
| CG5470 | 376 | 470 | 564 | 1000 | 1200 | | | | | | | |
| SL0902A600 CG5600 | 480 | 600 | 720 | 1350 | 1500 | 10 ¹⁰ Ω (at 100V) | | | | | | |

* - Particular component is not UL Recognized.

Product Characteristics

| | | | |
|------------------|--|--|--------------------------------|
| Materials | CG5xxxLS (Outline 500), CG5xxxxLTR & CG5350L-03TR (Outline 502), and CG5xxxL-02 (Outline 503): Device Nickel Plated 2-5 Microns Wire Tin Plated 17.5±12.5 Microns Construction Ceramic Insulator. | Product Marking | LF Logo, Voltage and date code |
| | CG5xxx (Outline 501), and CG5xxxMS & SL0902AxxxSM (Outline 505): Device Tin Plated 17.5±12.5 Microns Construction Ceramic Insulator. | Glow to arc transition current | < 0.5Amps |
| | | Glow Voltage | 140 Volts |
| | | Storage and Operational Temperature | -40 to +90 |

Voltage vs. Time Characteristic

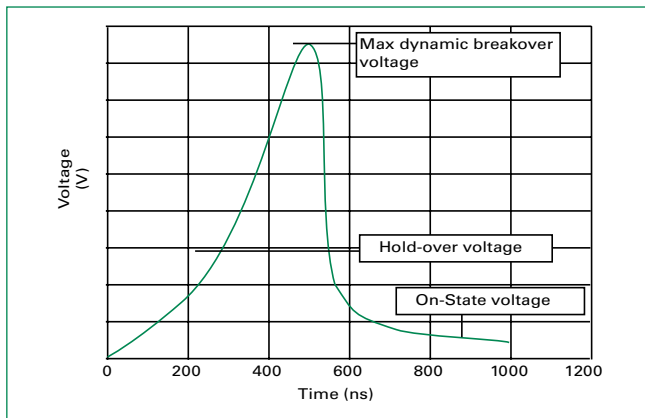

Typical Insertion Loss

| |
|---------------------|
| @ 1.0 GHz = 0.01 dB |
| @ 1.4GHz = 0.1 dB |
| @ 1.8 GHz = 0.53 dB |
| @ 2.1 GHz = 0.81 dB |
| @ 2.45 GHz= 1 dB |
| @ 2.8 GHz = 1.2 dB |
| @ 3.1 GHz = 1.5 dB |
| @ 3.5 GHz = 2.1 dB |

Device Dimensions

Outline 500 - CG5xxxLS

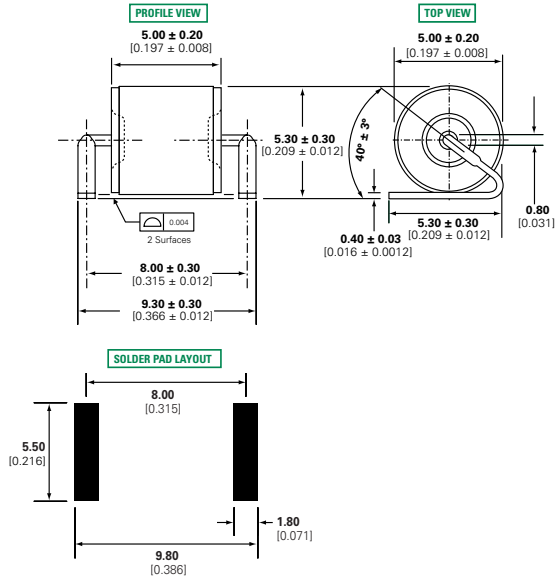

Outline 503 - CG5xxxL-02 (except CG5600L-02, see Outline 502)

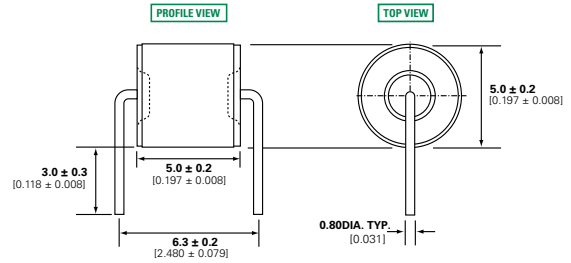

Outline 505 - CG5xxxMS and SL0902AxxxSM

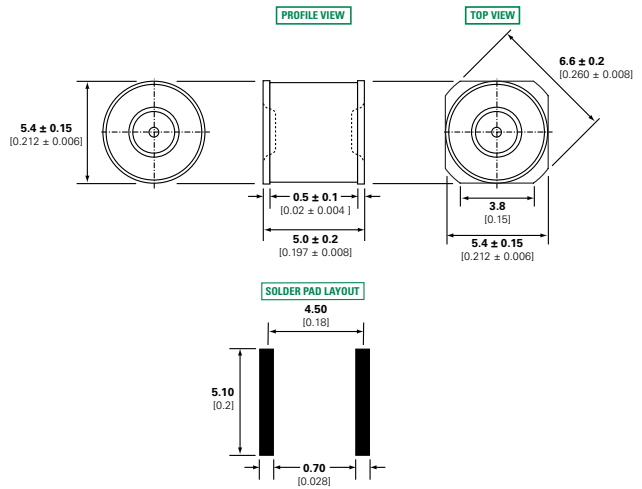

Outline 501 - CG5xxx

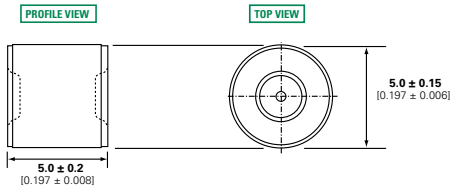

Outline 502 - CG5xxxLTR (also CG5350L-03TR, CG5600L-02)

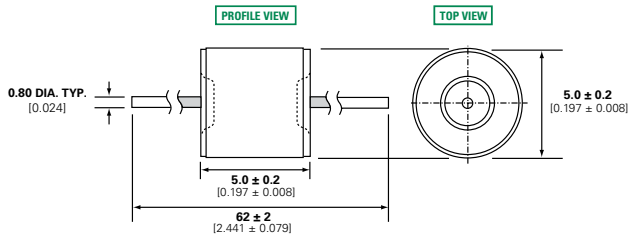

Soldering Parameters - Reflow Soldering (Surface Mount Devices)

| | | |
|--|------------------------------------|-------------------------|
| Reflow Condition | | Pb – Free assembly |
| Pre Heat | - Temperature Min ($T_{s(min)}$) | 150°C |
| | - Temperature Max ($T_{s(max)}$) | 200°C |
| | - Time (Min to Max) (t_s) | 60 – 180 secs |
| Average ramp up rate (Liquidus Temp (T_L) to peak) | | 3°C/second max |
| $T_{s(max)}$ to T_L - Ramp-up Rate | | 5°C/second max |
| Reflow | - Temperature (T_L) (Liquidus) | 217°C |
| | - Temperature (t_L) | 60 – 150 seconds |
| Peak Temperature (T_p) | | 260 ^{+0/-5} °C |
| Time within 5°C of actual peak Temperature (t_p) | | 10 – 30 seconds |
| Ramp-down Rate | | 6°C/second max |
| Time 25°C to peak Temperature (T_p) | | 8 minutes Max. |
| Do not exceed | | 260°C |

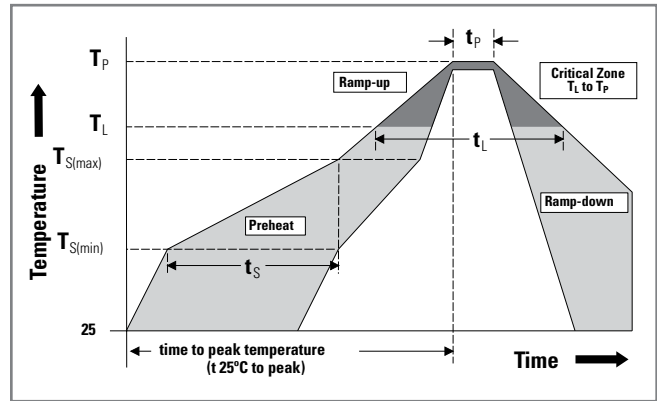

Soldering Parameters - Hand Soldering

Solder Iron Temperature: 350° C +/- 5°C
Heating Time: 5 seconds max.

Soldering Parameters - Wave Soldering (Thru-Hole Devices)

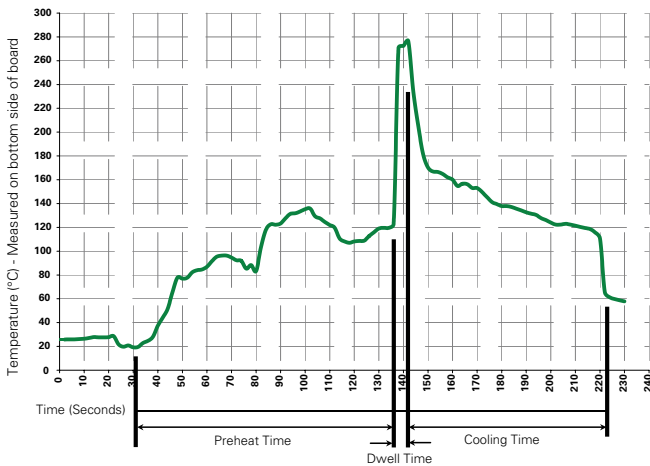

Recommended Process Parameters:

| Wave Parameter | Lead-Free Recommendation |
|---|-----------------------------------|
| Preheat: (Depends on Flux Activation Temperature) | (Typical Industry Recommendation) |
| Temperature Minimum: | 100° C |
| Temperature Maximum: | 150° C |
| Preheat Time: | 60-180 seconds |
| Solder Pot Temperature: | 280° C Maximum |
| Solder Dwell Time: | 2-5 seconds |

Note: These devices are not recommended for IR or Convection Reflow process.