



TAOGLAS®



Datasheet

GPS/GLONASS/BeiDou Patch

Part No:
CGGBP.35.6.A.02

Description

GPS/GLONASS/Galileo/BeiDou Embedded Patch Antenna

Features:

Dielectric Ceramic
BeiDou 1561MHz / GPS-Galileo 1575MHz / GLONASS 1602MHz
Pin Mount
Dimensions: 35mm*35mm*6.5mm
RoHS & Reach Compliant

1.	Introduction	2
2.	Specification	3
3.	Antenna Characteristics	5
4.	Radiation Patterns	9
5.	Mechanical Drawing	13
6.	Packaging	14
7.	Antenna Integration Guide	15
<hr/>		
	Changelog	22

Taoglas makes no warranties based on the accuracy or completeness of the contents of this document and reserves the right to make changes to specifications and product descriptions at any time without notice. Taoglas reserves all rights to this document and the information contained herein. Reproduction, use or disclosure to third parties without express permission is strictly prohibited.



1. Introduction



The Taoglas CGGBP.35.6.A.02 is a Circularly Polarized embedded GNSS patch designed for use across the full single band GNSS spectrum.

This 35mm square ceramic GPS/GLONASS/Galileo/BeiDou patch antenna's wide band of operation leads to excellent gain and radiation pattern stability on all GNSS system bands.

Typical applications include:

- Agriculture
- Asset tracking systems
- Navigation

Compared to using a smaller antenna, this will translate into the GNSS system having much higher location accuracy, improved reliability of lock in urban areas, better signal reception, with more satellites acquired and a quicker time to first fix.

The patch is mounted via pin and double-sided adhesive and can be custom tuned to a device subject to NRE, for further information please contact your regional Taoglas customer support team.

2. Specification

GNSS Frequency Bands					
GPS	L1 1575.42 MHz	L2 1227.6 MHz	L5 1176.45 MHz		
	■	□	□		
GLONASS	G1 1602 MHz	G2 1248 MHz	G3 1207 MHz		
	■	□	□		
Galileo	E1 1575.24 MHz	E5a 1176.45 MHz	E5b 1201.5 MHz	E6 1278.75 MHz	
	■	□	□	□	
BeiDou	B1C 1575.42 MHz	B1I 1561 MHz	B2a 1176.45 MHz	B2b 1207.14 MHz	B3 1268.52 MHz
	■	■	□	□	□
L-Band	L-Band 1542 MHz				
	□				
QZSS (Regional)	L1 1575.42 MHz	L2C 1227.6 MHz	L5 1176.45 MHz	L6 1278.75e6	
	■	□	□	□	
IRNSS (Regional)	L5 1176.45 MHz				
	□				
SBAS	L1/E1/B1 1575.42 MHz	L5/B2a/E5a 1176.45 MHz	G1 1602 MHz	G2 1248 MHz	G3 1207 MHz
	■	□	■	□	□

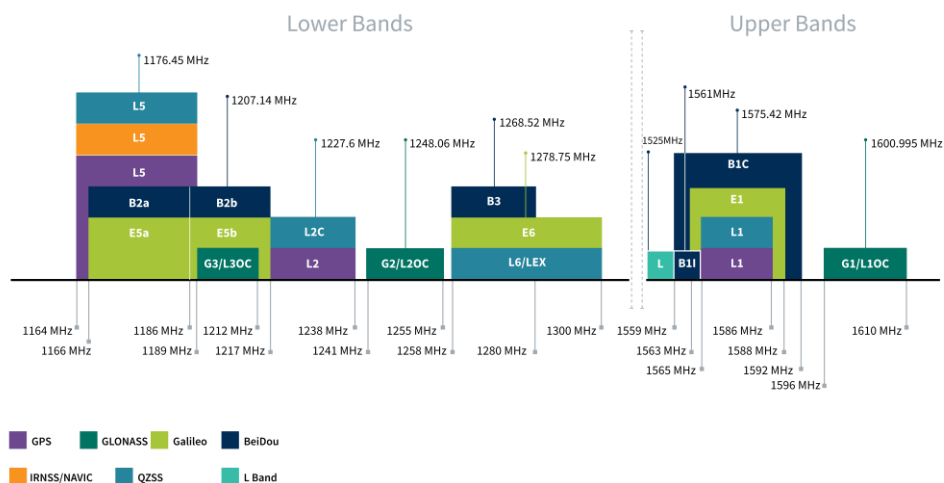

GNSS Bands and Constellations

GNSS Electrical			
Frequency (MHz)	1561	1575.42	1603
VSWR (max.)	1:1	1:1	1:1
Passive Antenna Efficiency (%) (Without cable loss)	93.24	94.24	94.22
Passive Antenna Gain at Zenith (dBic) (Without cable loss)	5.13	5.18	5.24
Polarization	RHCP		
Impedance	50 Ω		

Mechanical	
Dimensions	35 x 35 x 6.5mm
Weight	29g
Material	Ceramic

Environmental	
Operation Temperature	-40°C to 85°C

3. Antenna Characteristics

3.1 Test Setup

AUT



Vector Network Analyzer

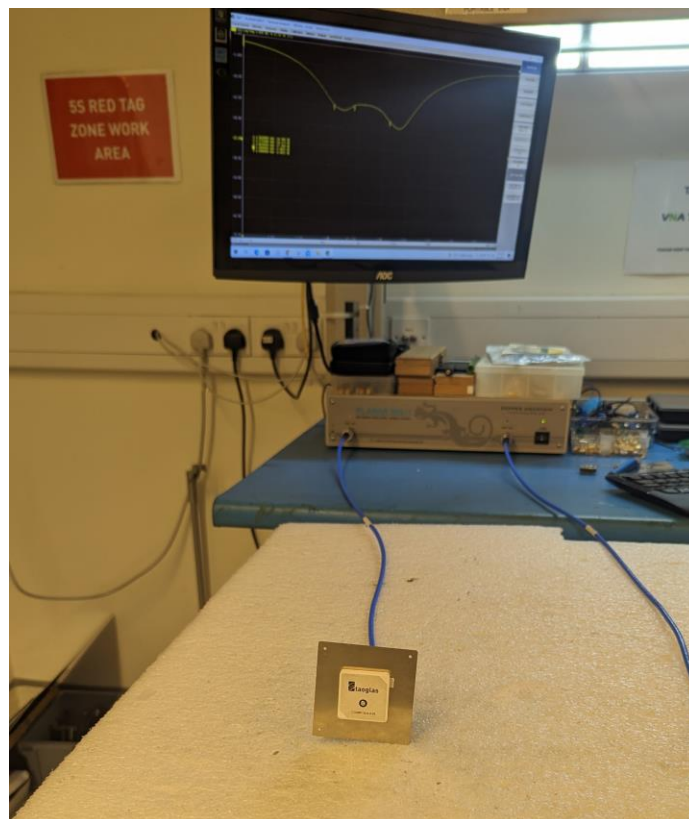

On 70mmx70mm Ground Plane

3.2 Return Loss

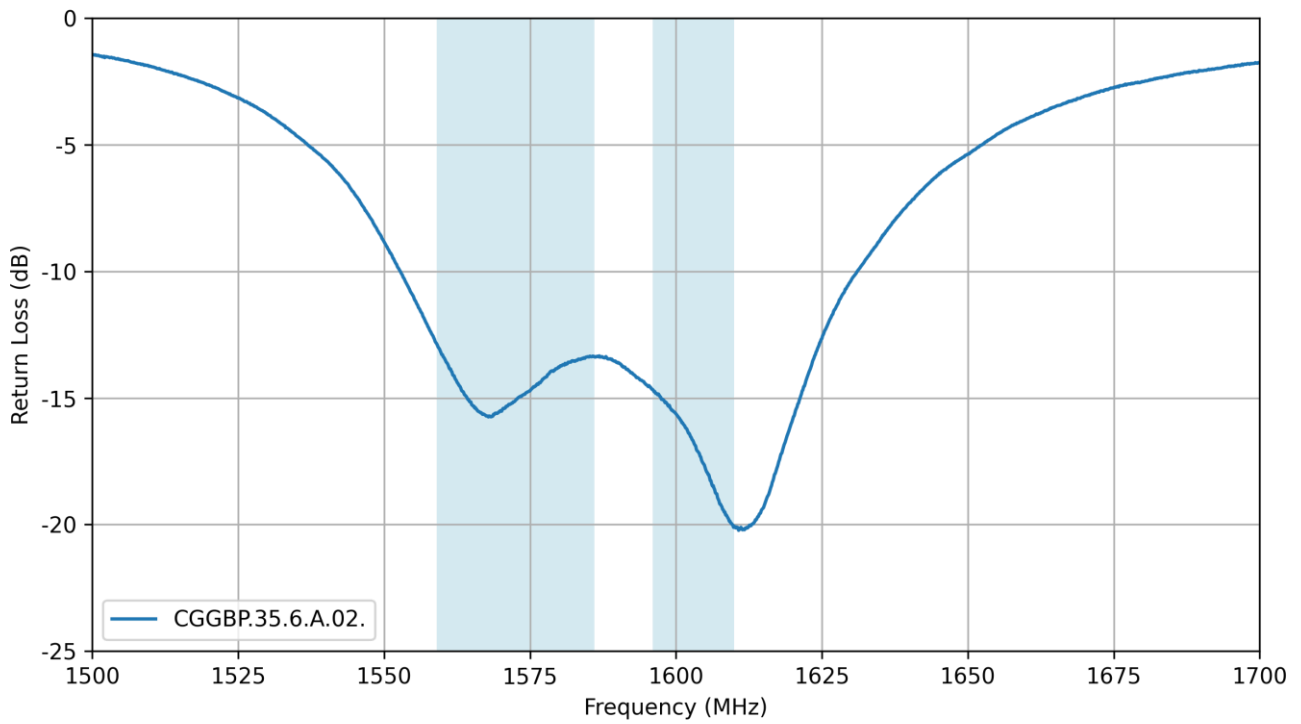

3.3 VSWR

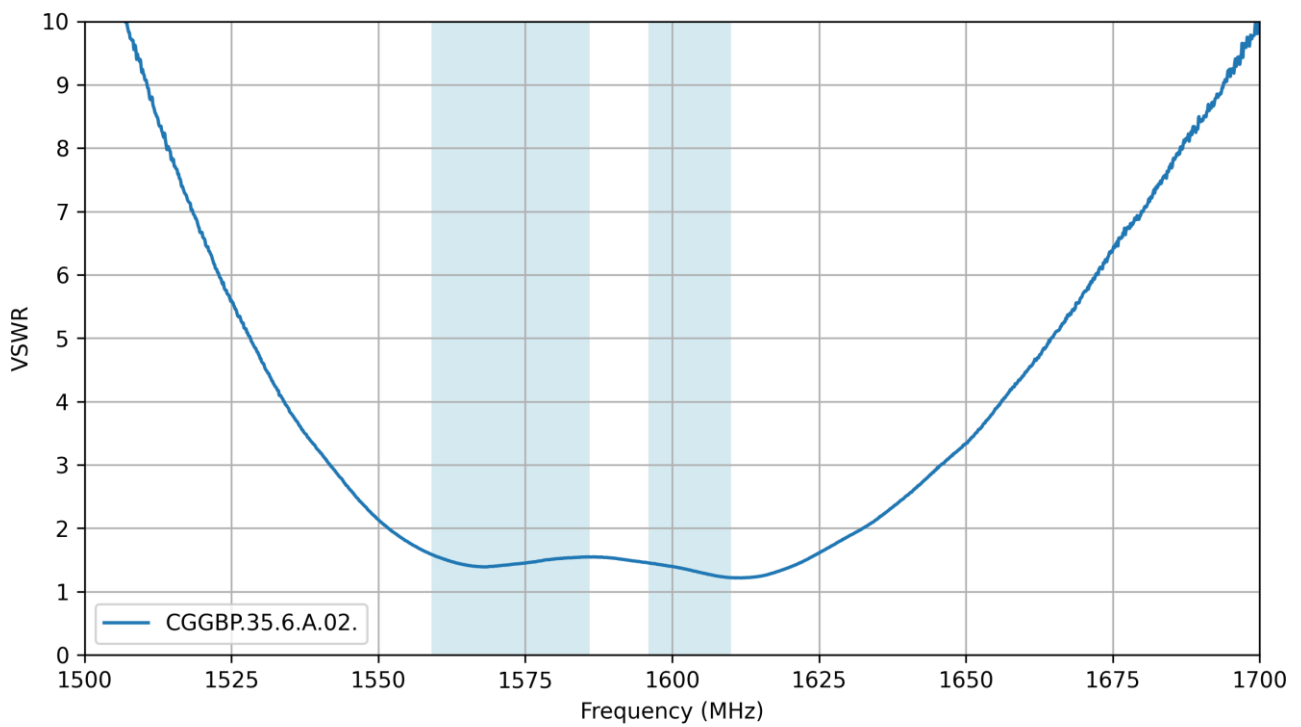

3.4 Efficiency

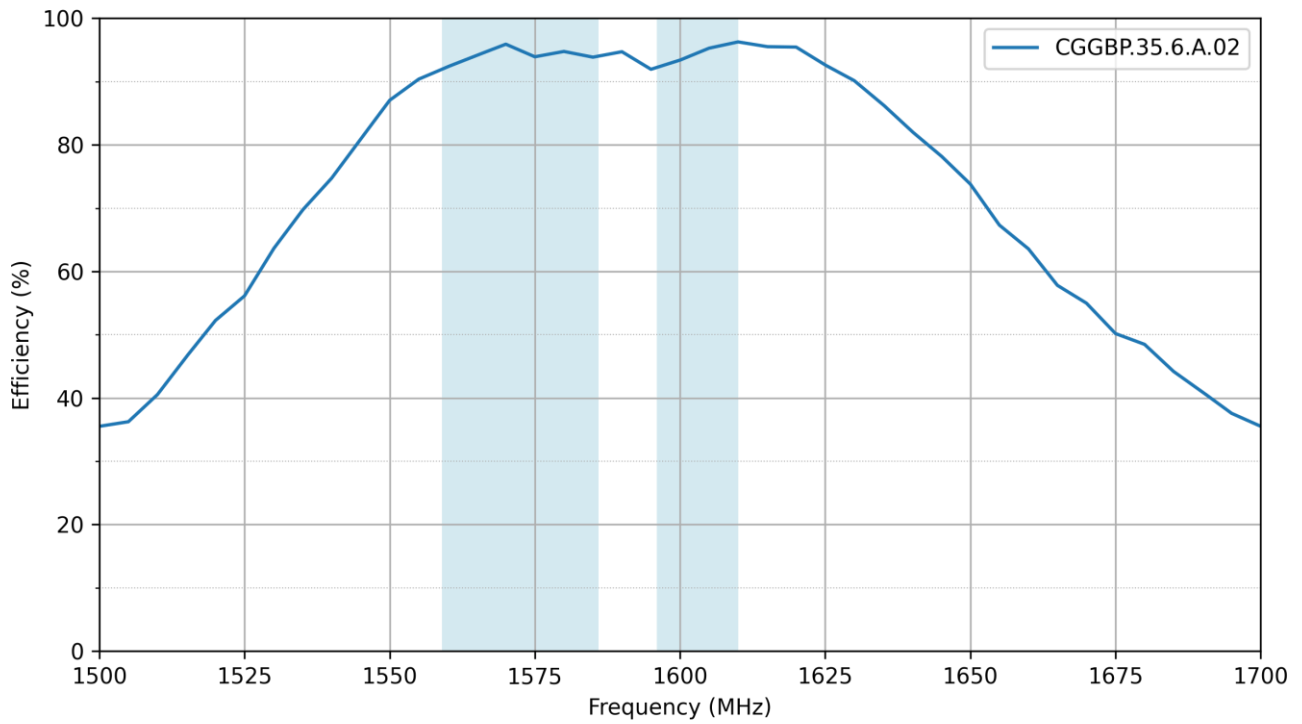

3.5 Average Gain

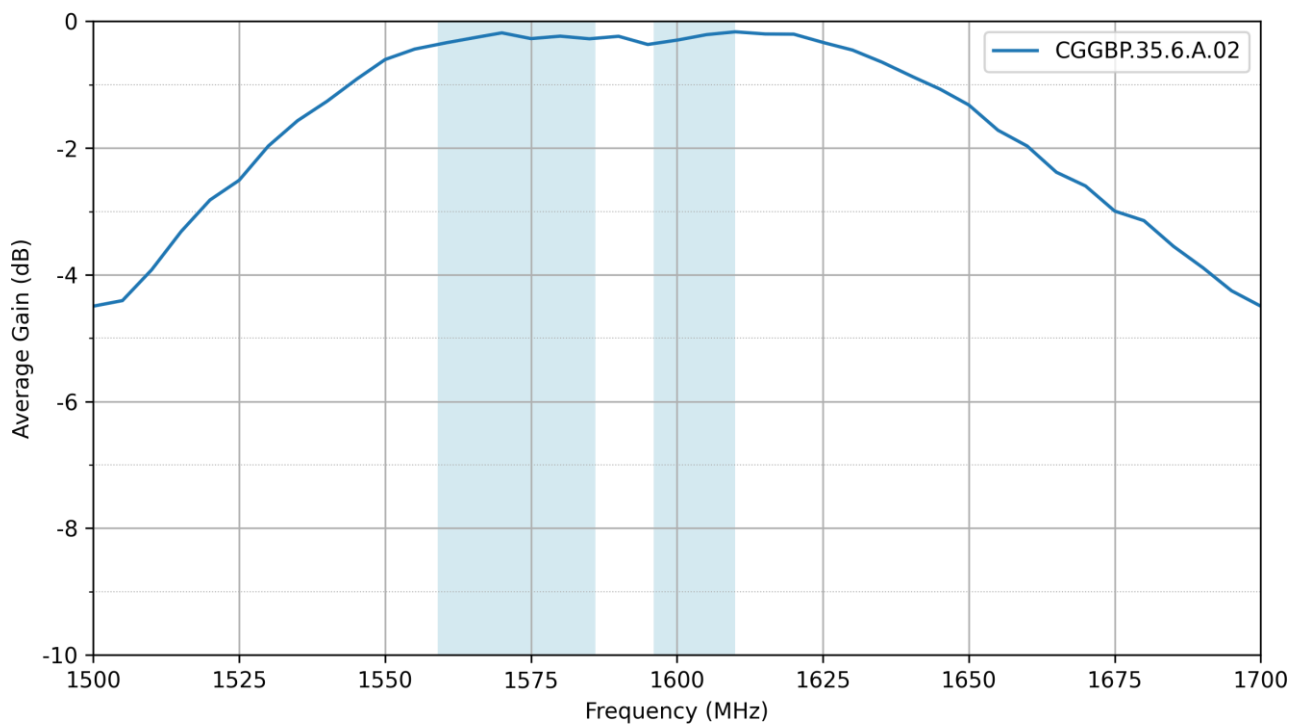

3.6 Peak Gain

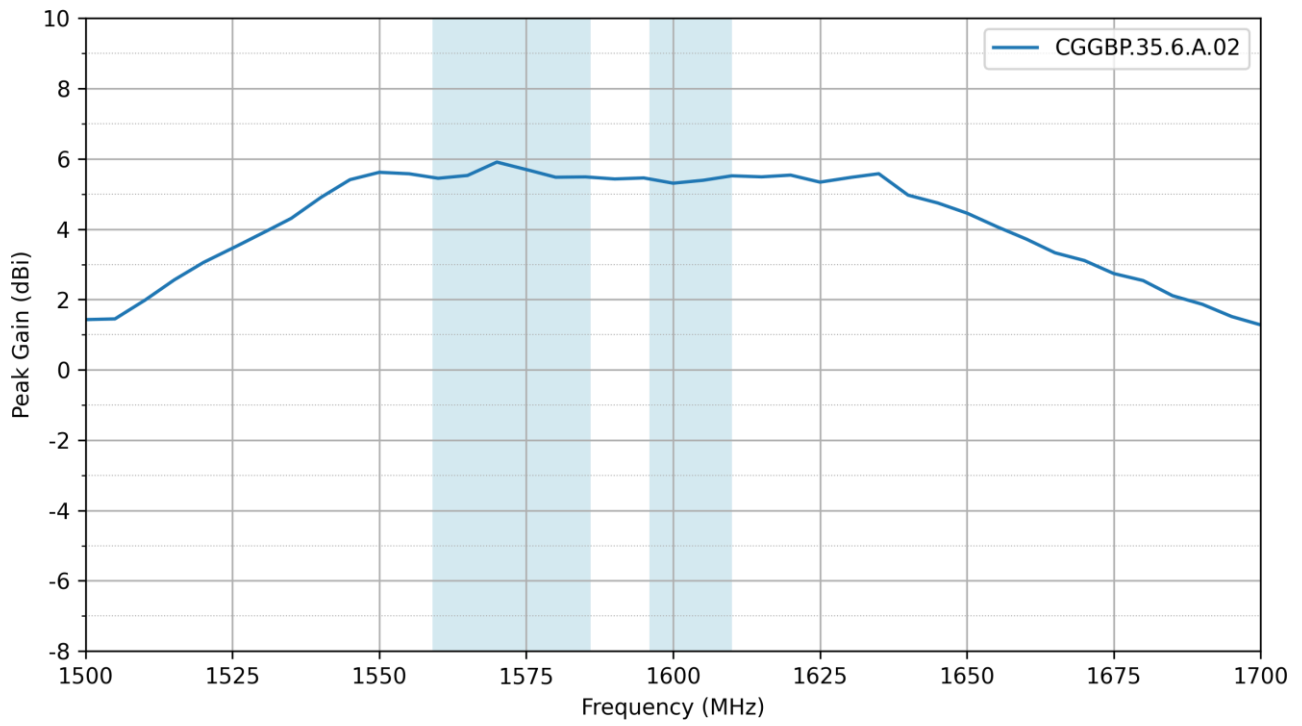

4. Radiation Patterns

4.1 Test Setup

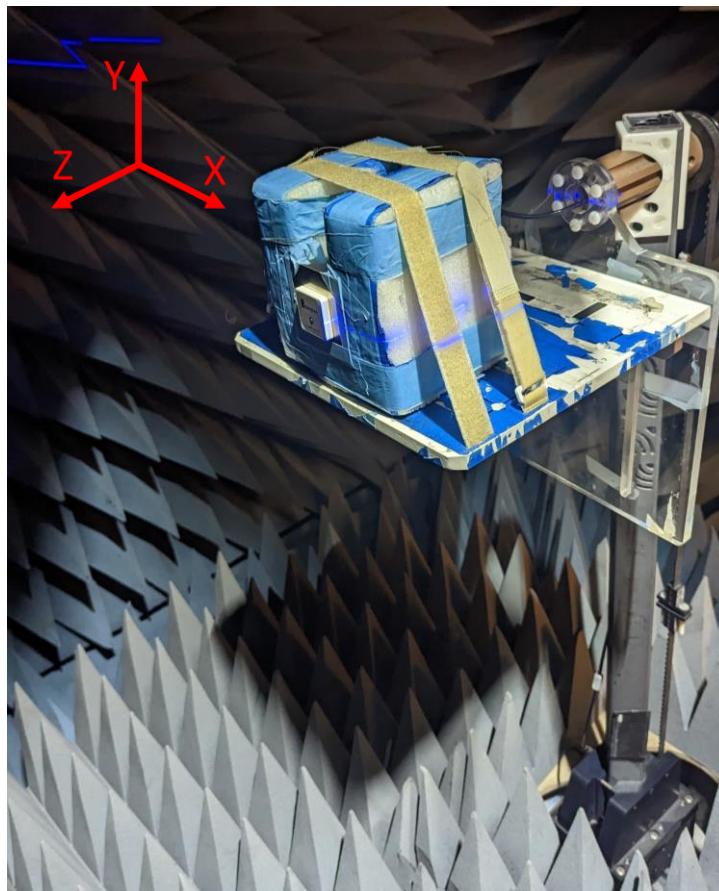
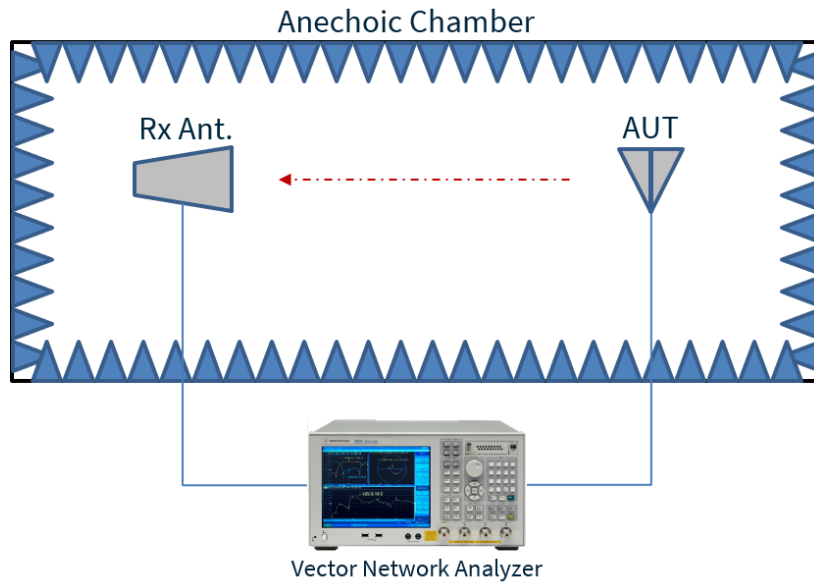

On 70mmx70mm Ground Plane

4.2 CGGBP.35.6.A.02 Patterns at 1575 MHz

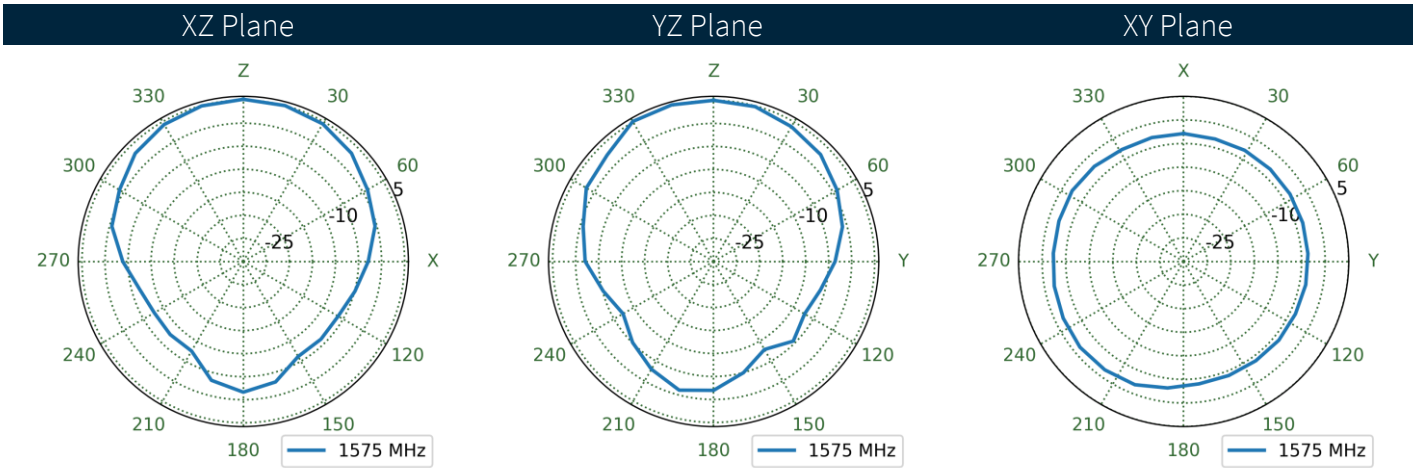
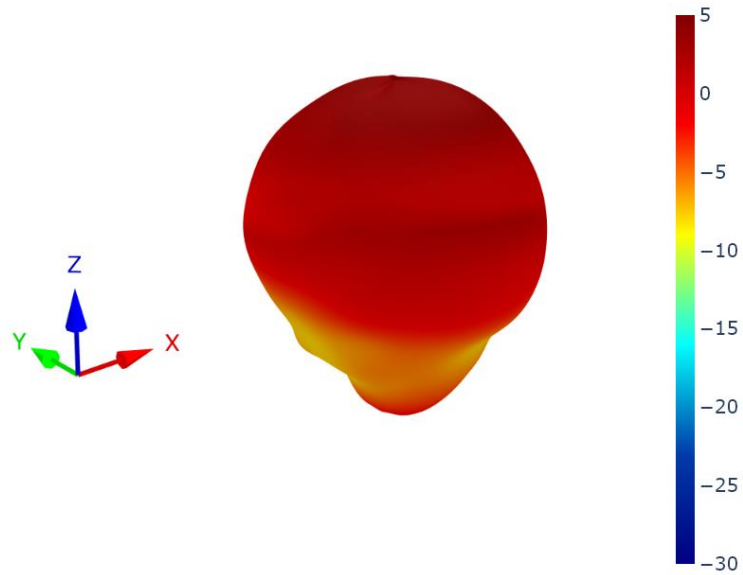

4.3 CGGBP.35.6.A.02 Patterns at 1605 MHz

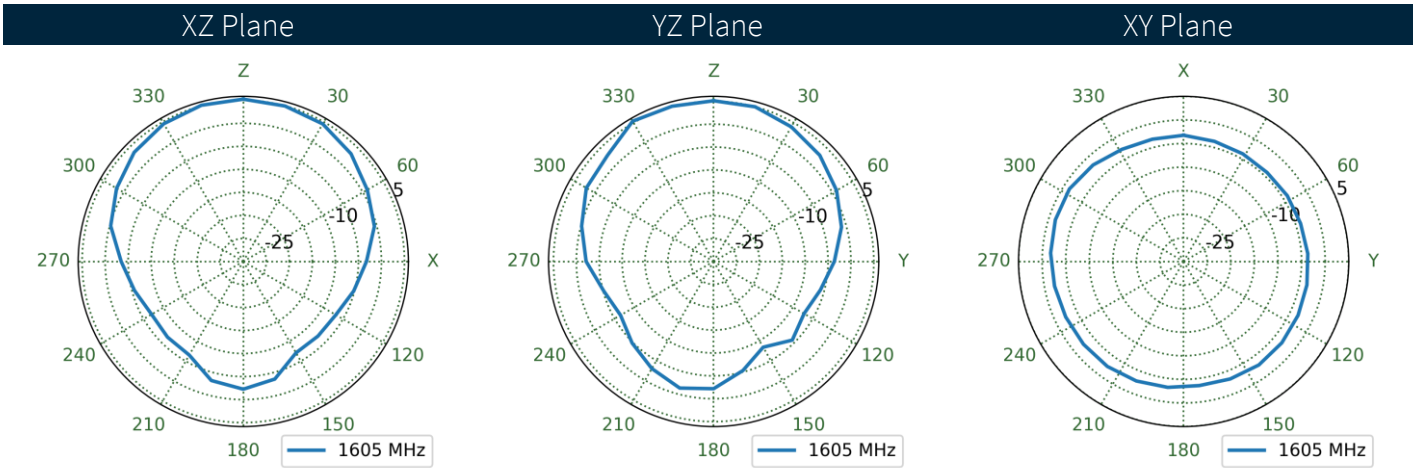
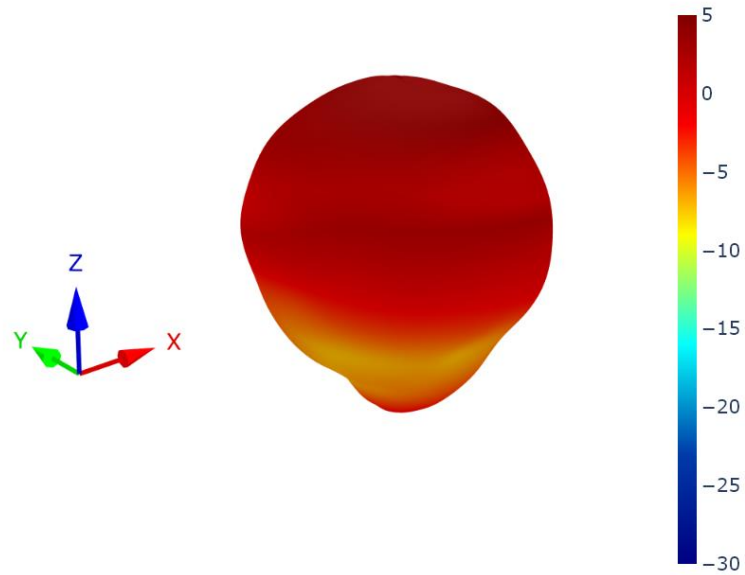

4.4 CGGBP.35.6.A.02 Patterns at 1560 MHz

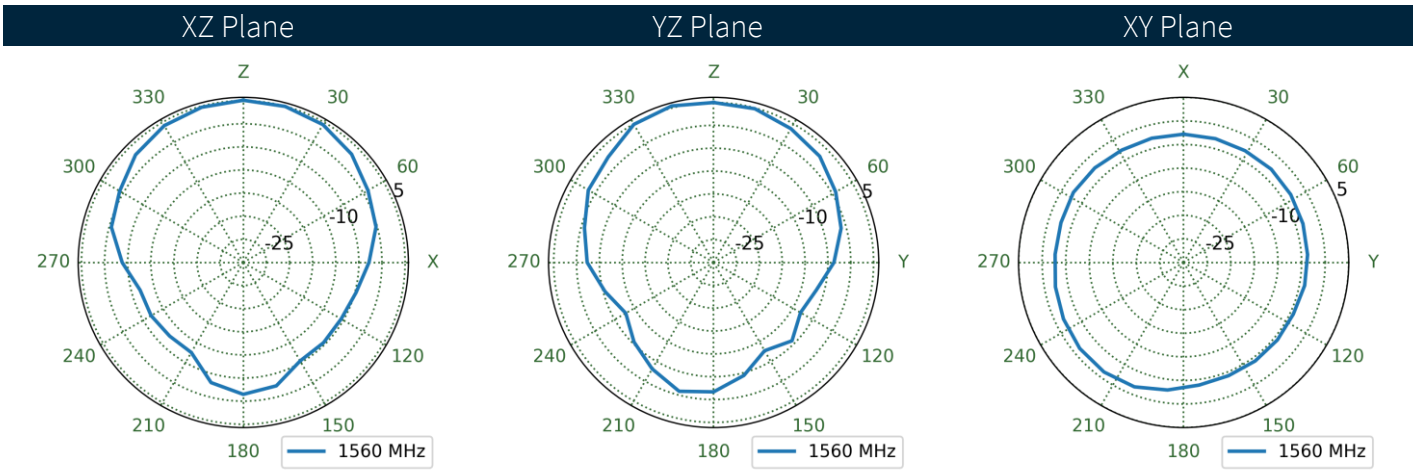
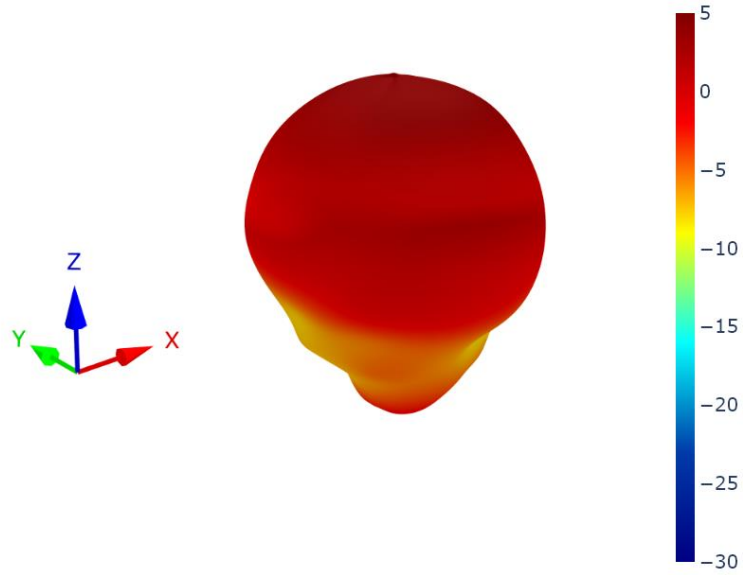

5. Mechanical Drawing

ISO NO.: EDW-18-8-0694

STATE: Release

NOTES: 1. Double sided adhesive area

REV.	DESCRIPTION	ENG.	APPROVED	DATE
△	Initial Design	Eva	Paul	2018/09/06
△	Replace the new LOGO <EDR-18-8-258>	Rachel	Aaron	2019/09/24
△	EC-21-08-010	Mickey	Buluto	2021/03/02

Top View

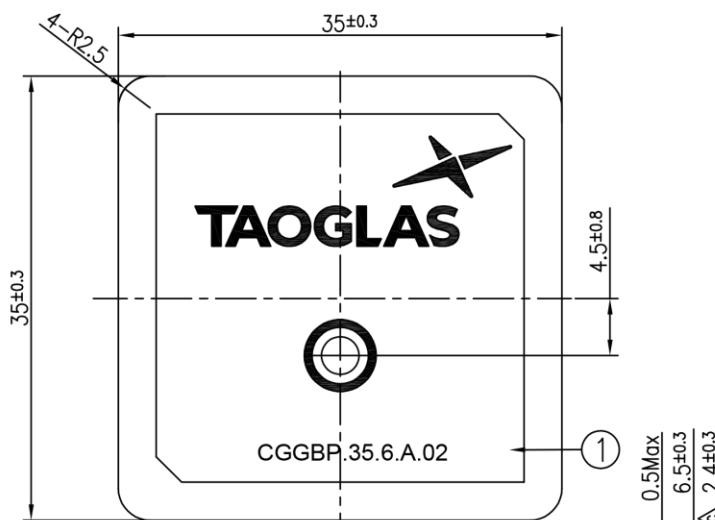

Side View

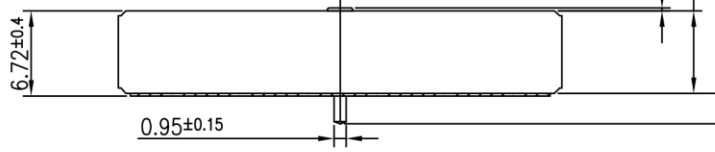

Bottom View

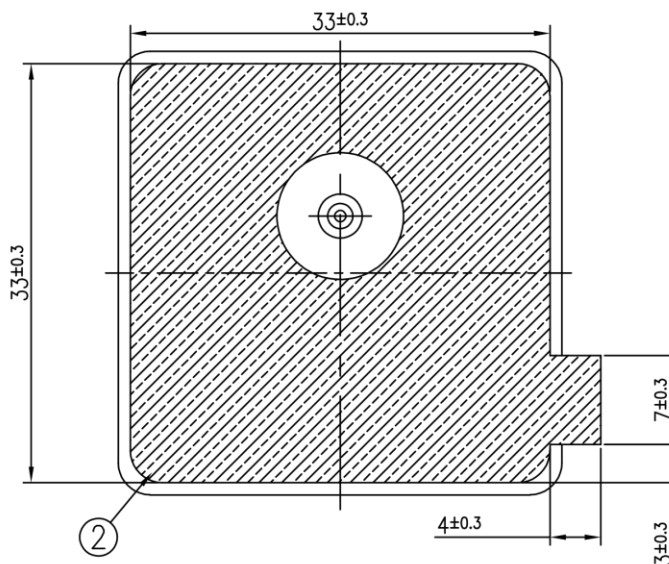

	Name	P/N	Material	Finish	QTY
1	Patch	0015160040007A	Ceramic	Clear	1
2	Double sided Adhesive	0015160040007A	NIITO 5015	White Liner	1

APPROVED BY: Joanna	TW Design Centre This drawing and its inherent design concepts are property of Taoglas. Not to be copied or given to third parties without the written consent of Taoglas.
CHECK BY: Martin	
DRAWN BY: Sandy	
DATE: 2013/10/31	
UNLESS OTHERWISE SPECIFIED TOLERANCES ON:	TITLE : GPS/GLONASS/BEIDOU Patch Antenna 35*35*6.5mm
THIRD ANGLE PROJECTION	PART NO. : CGGBP.35.6.A.02
	UNIT: mm SCALE: 2:1 PAGES: 1/1 REV. C

6. Packaging

12 pcs CGGP.35.6.A.02
 Tray Dimensions – 240*140*20mm
 Weight – 280g

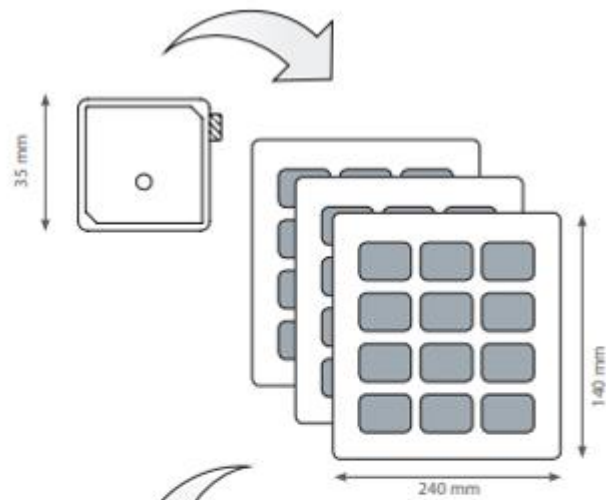

72 pcs CGGP.35.6.A.02 per inner carton
 Inner carton dimensions – 261*152*118mm
 Weight – 1.675Kg

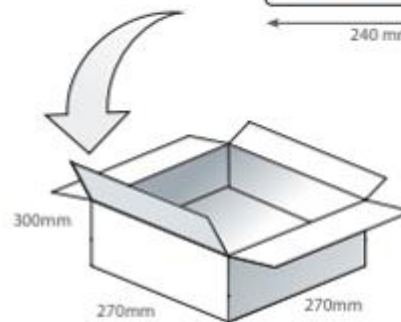

288 pcs CGGP.35.6.A.02 per carton
 Carton dimensions – 330*280*270mm
 Weight – 6.7Kg

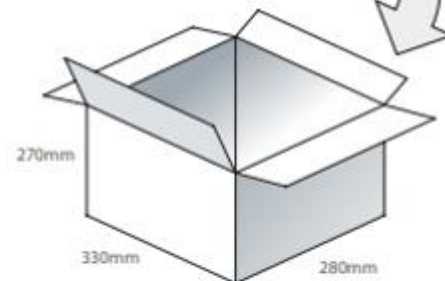

Pallet dimensions – 1200*1000*1550mm
 60 Cartons per pallet
 12 Cartons per layer
 5 Layers

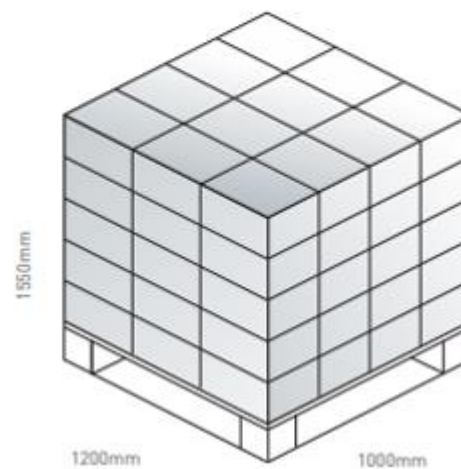

7. Antenna Integration Guide

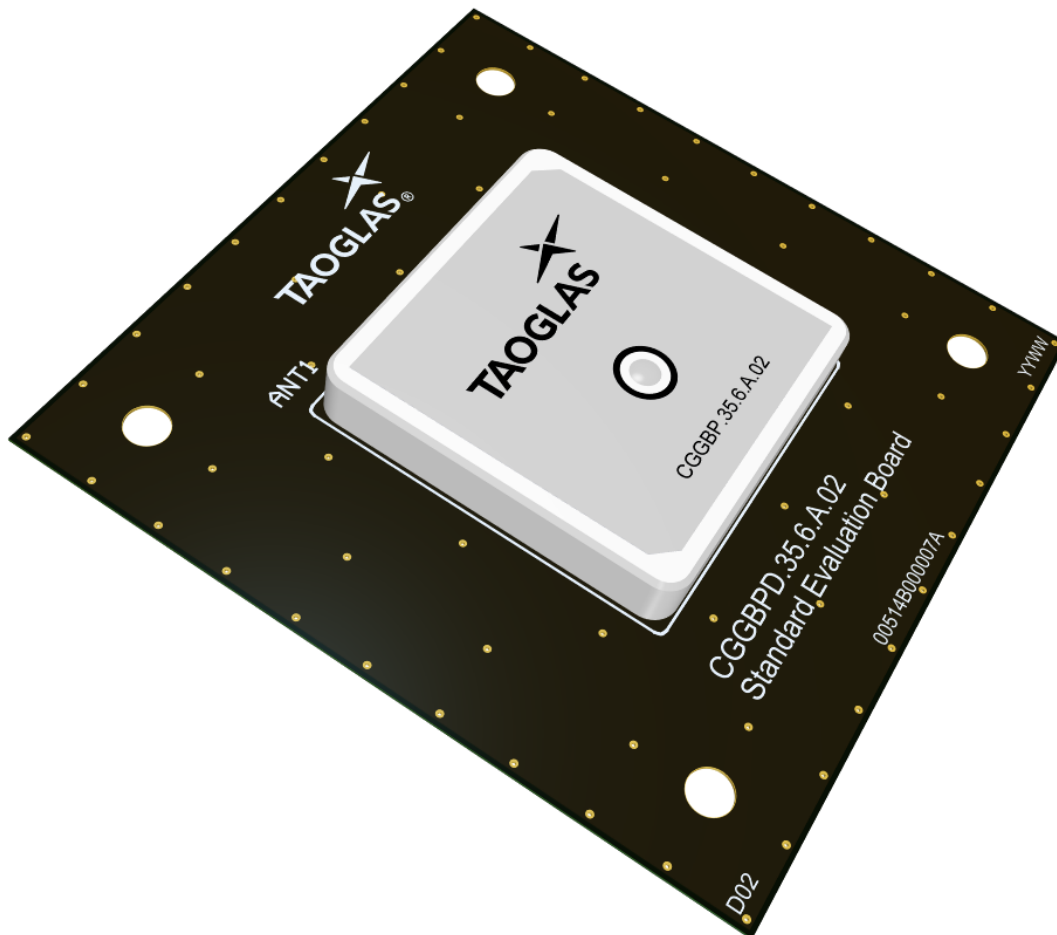

7.1 Schematic and Symbol Definition

The circuit symbol for the antenna is shown below. The antenna has 1 pin as indicated below.

Pin	Description
1	RF Feed

CGGBP.35.6.A.02
ANTI

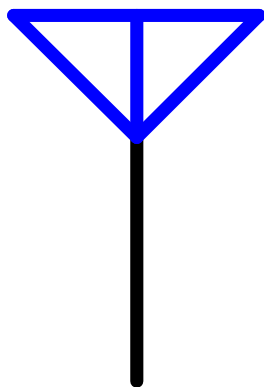

7.2 Antenna Integration

The antenna should be placed at the center of the ground plane with a length and width of 70mm. Maintaining a square symmetric ground plane shape and symmetric environment around the antenna is critical to maintaining the excellent axial ratio and phase center performance shown in this datasheet.



Top Side w/ Solder Mask



Top Side w/o Solder Mask

7.3 PCB Layout

The footprint and clearance on the PCB must comply with the antenna specification. The PCB layout shown in the diagram below demonstrates the antenna footprint.

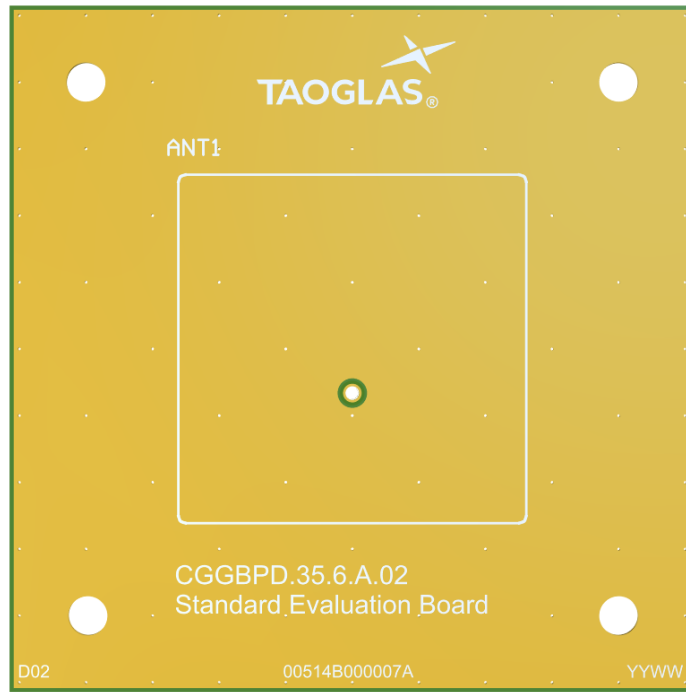

Topside

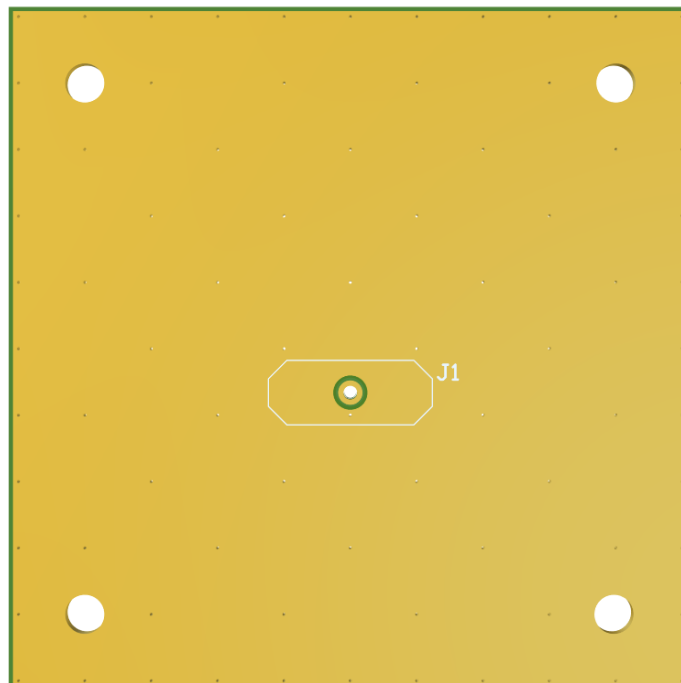

Bottom Side

7.4 Evaluation Board

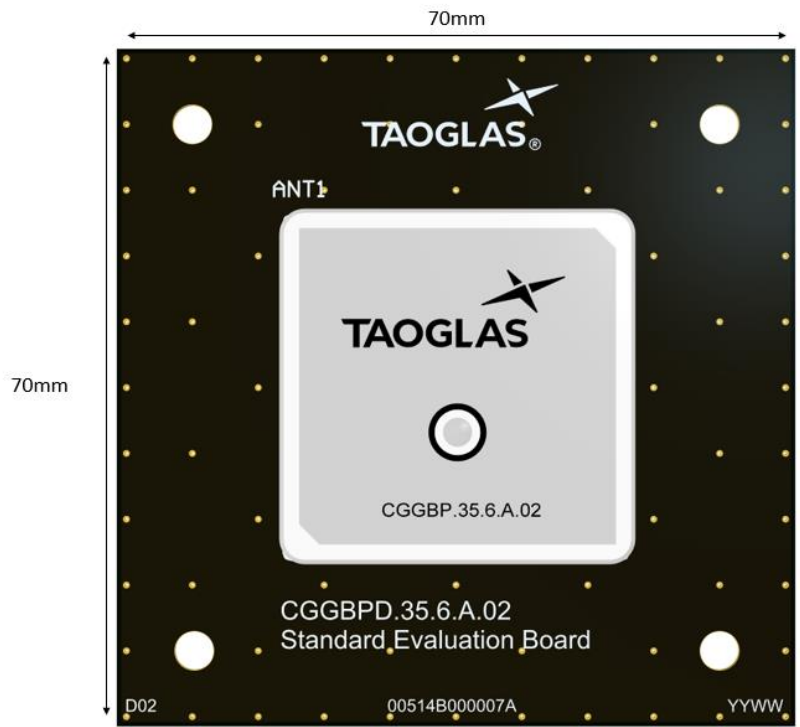

Topside

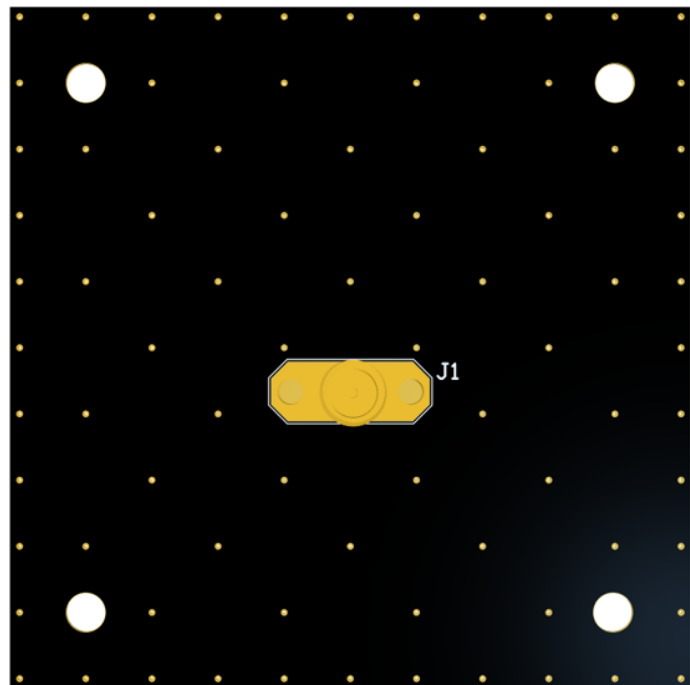

Bottom Side

7.5 Evaluation Board Drawing

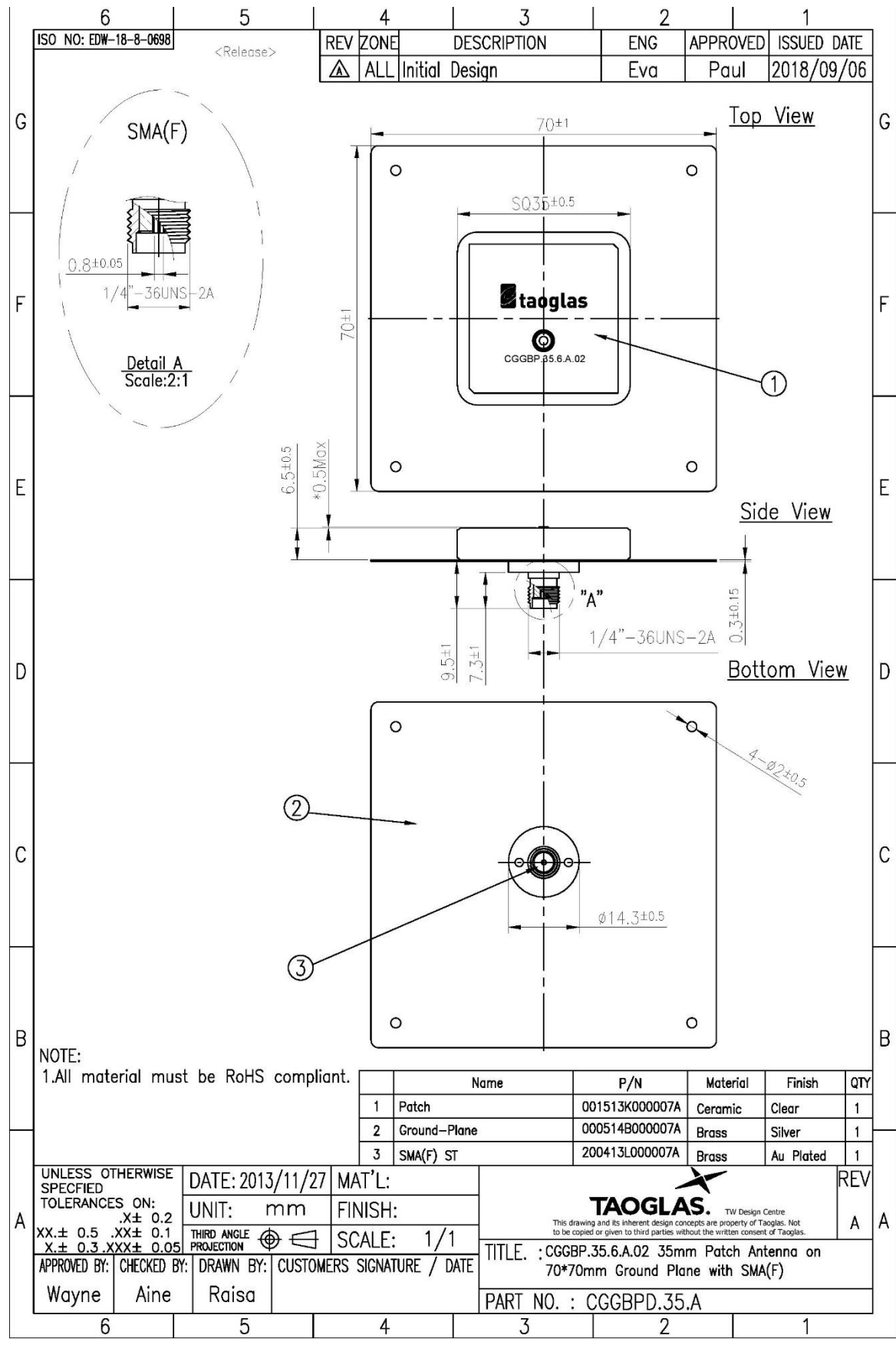

7.6 Footprint

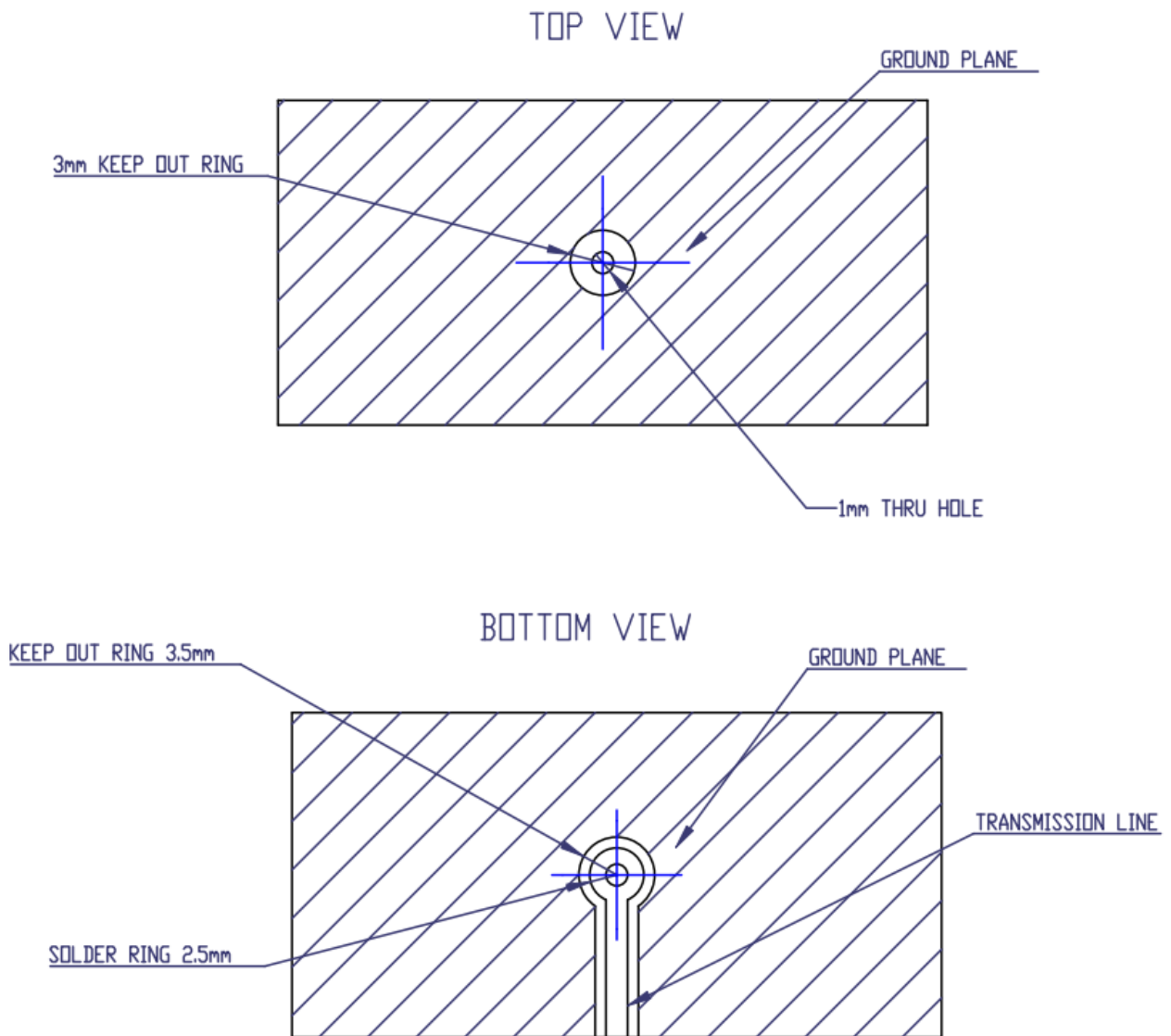

Changelog for the datasheet

SPE-14-8-018 – CGGBP.35.6.A.02

Revision: J (Current Version)

Date:	2023-06-08
Changes:	Updated Graphs Updated PCB Footprint
Changes Made by:	Aswin Biju

Previous Revisions

Revision: I (Current Version)

Date:	2023-05-12
Changes:	Updated Axial Ratio Graph.
Changes Made by:	Gary West

Revision: D

Date:	2017-06-27
Changes:	
Changes Made by:	David Connolly

Revision: H

Date:	2022-02-24
Changes:	Integration guide added
Changes Made by:	Cesar Sousa

Revision: C

Date:	2015-01-06
Changes:	PCB Footprint
Changes Made by:	Made by Andy Mahoney

Revision: G

Date:	2021-06-08
Changes:	Pin Length changed to 2.4mm Drawing updated
Changes Made by:	Dan Cantwell

Revision: B

Date:	2014-11-17
Changes:	Evaluation Board Added
Changes Made by:	Aine Doyle

Revision: F

Date:	2020-01-27
Changes:	Installation Guide Amended
Changes Made by:	Jack Conroy

Revision: A (Original First Release)

Date:	2014-03-04
Notes:	
Author:	Aine Doyle

Revision: E

Date:	2018-03-27
Changes:	Installation Guide Amended
Changes Made by:	Jack Conroy