

High speed protected digital termination array

Data brief

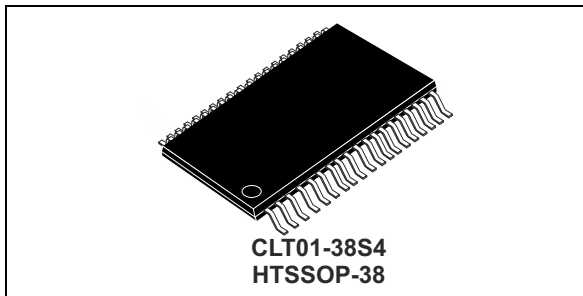

Features

- 8-input circuit in common ground low side topology
- Wide range input DC voltage V_i : -30 V to 35 V
- On state threshold: < 11 V with $R_i = 2.2$ k Ω
- Off state threshold: $I_{in} > 1.5$ mA or $V_i > 5$ V
- Protected against -30 V reverse polarity
- Typical $I_{LIM} = 2.1$ to 2.6 mA adjustable current limiters
- Tight current tolerance including temperature compensation: $\pm 10\%$
- Serial output with an SPI communication bus
- Clock frequency up to 6.25 MHz
- $C_{PHA} = C_{POL} = 0$ bus master operation
- Multi CLT operation in daisy chain connection
- 16-bit mode: 8 bits for data / 8 bits for control
 - Minimum capture time: 4 μ s
 - Input data rate: 200 kbps/100 kHz
 - Minimum propagation transfer time: 7 μ s
- 8-bit mode: 8 bits for data
 - Minimum capture time: 2.5 μ s
 - Input data rate: 400 kbps/200 kHz
 - Minimum propagation transfer time: 4 μ s
- $V_{CC} = -0.3$ to +35 V with $R_C = 2.2$ k Ω
- Ambient temperature range: -25 to +85°C
- Digital inputs for programmable logic controller and decentralized I/O modules

Benefits

- Enables input to meet type 1, 2 and 3 characteristics of IEC 61131-2 standard
- Compatible operation with 2 wires proximity sensor according EN 60947-5-2 standard
- Compact board with surface mount integration and reduced count of isolated couplers
- Reduces the count of input-output of the bus controller circuit
- Provides energy-less input LED visual status
- Enhanced functional reliability
- Built-in over voltage robustness and immune data transfer
- Reduced dissipation: 78 mW max. per channel

Complies with following standards ($R_i = 2.2$ Ω , $R_C = 2.2$ Ω , $C = 33$ nF):

- Electrostatic discharge, IEC 61000-4-2:
 - ± 8 kV contact discharge
 - ± 15 kV air discharge
- Electrical transient immunity IEC 61000-4-4^(a):
 - $F_{SCK} = 6.25$ MHz, ± 3 kV
 - $F_{SCK} = 10$ kHz, ± 4 kV
- Voltage surge IEC 61000-4-5
 - Input: ± 15 kV
 - Power supply: ± 2.5 kV

Applications

- Programmable logic controller and decentralized input modules
- High speed protected termination for digital input with serialized SPI output
- IEC 61131-2 type 1, 2 and 3.

a. With 470 pF grounded on CS and 100 pF grounded on CLK

1 Description

CLT01-38S4 adds to the existing current limiter family. Still focusing on power consumption savings, the whole series allows each customer to find the right solution.

The CLT01-38S4 is an octal input termination device with a high speed SPI output. Its maximum input data rate is 400 kbps while the output SPI speed is 6.25 MHz.

As in previous versions, robustness is a key feature of CLT01-38S4. The product is compliant with surge standards defined in IEC 61000-4-x.

It can run all types of sensor according to IEC 61131-2. Type 1 and 3 with a 2.35 mA limited current and type 2 using two inputs per sensor with the correct R_{REF} .

2 Characteristics

2.1 Simplified block diagram

Figure 1. Simplified block diagram

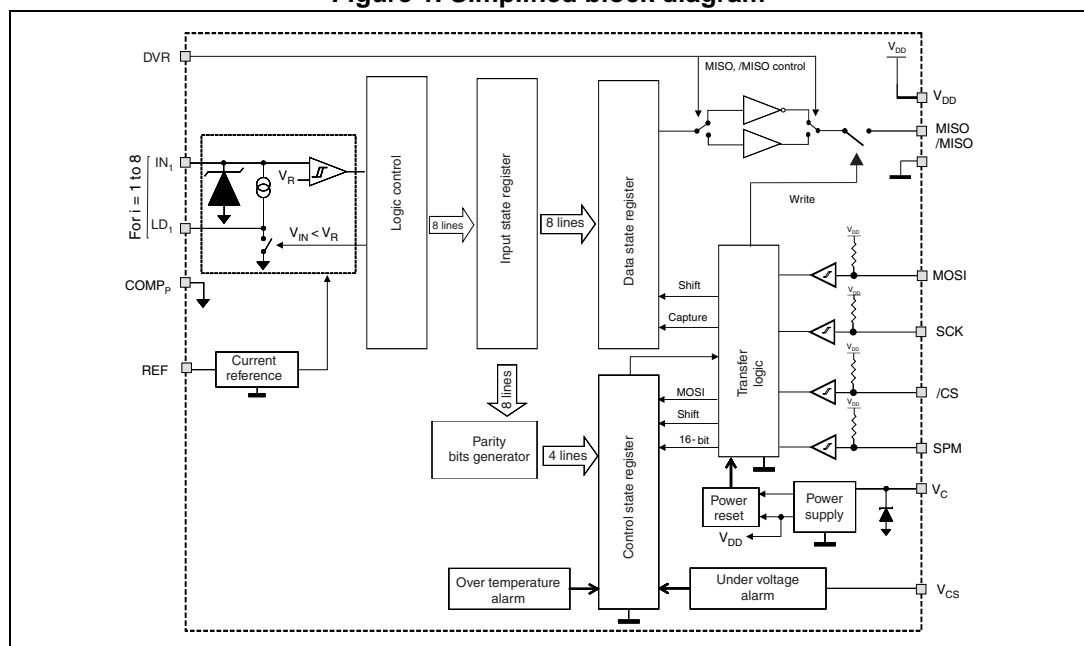

2.2 Basic application diagram

Figure 2. Basic application diagram

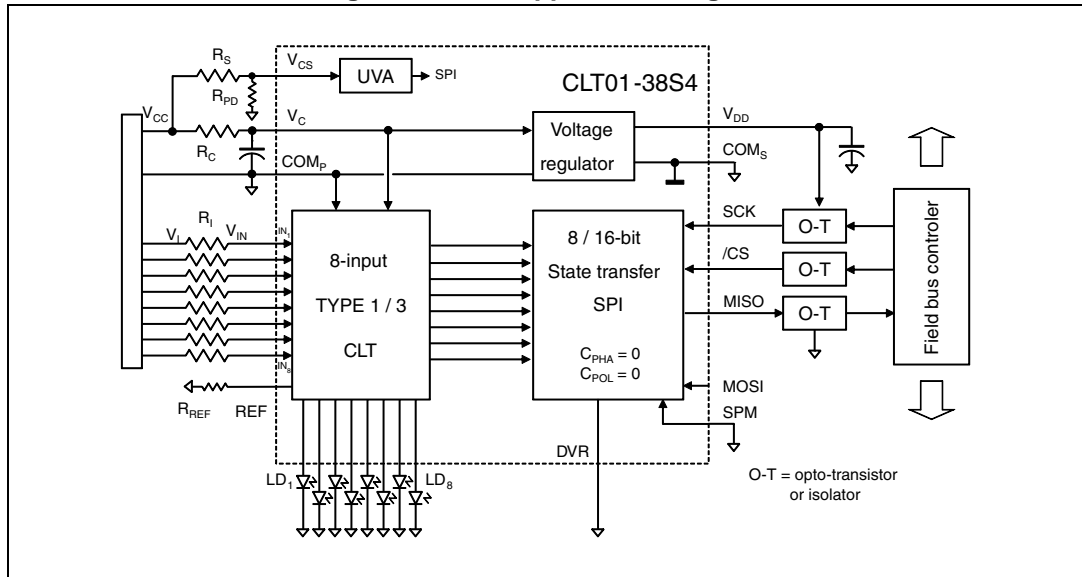

2.3 Input I/O pin descriptions

Figure 3. Pinout description of the HTSSOP-38 version (top view)

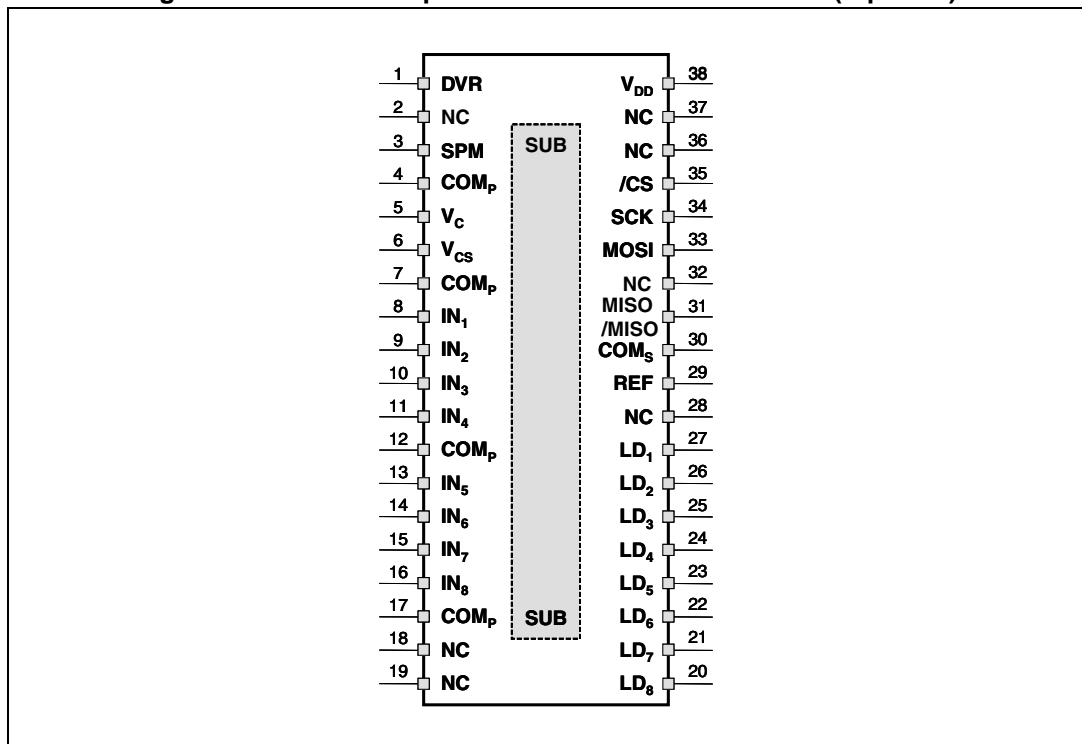

Table 1. Pin-out name and description

Name	Type	description	Pin name
IN _I	Power input	Logic input with a current regulation behavior, I = 1 to 8	8 to 11, 13 to 16
LD _I	Power output	LED output driver with a current regulation behavior, I = 1 to 8	20 to 27
VC	Power input	24 V sensor power supply	5
VCS	Signal input	24 V sensor power supply sensing input	6
COMP	Ground	Power ground of power sensor supply	4, 7, 12, 17
VDD	Power output	5 V logic power supply	38
COMS	Ground	Signal ground of logic / output section	30
REF	Signal input	Input current limiter reference setting	29
SPM	Signal input	SPI shift register length selector (8 or 16 bits)	3
/CS	Logic input	SPI chip Select signal	35
SCK	Logic input	SPI serial clock signal	34
MOSI	Logic output	SPI serial data input signal	33
DVR	Signal input	SPI data selector: DVR = GND → pin 31 = MISO DVR = VDD → pin 31 = /MISO	1
MISO or /MISO	Logic output	SPI serial data output signal or Inverting SPI serial data output signal	31
SUB	Substrate	Exposed pad: connected to die substrate, to connect to COMP	Exposed pad
NC		Not connected (or to be connected to COMP)	2, 18, 19, 28, 36, 37

3 Package information

- Epoxy meets UL94, V0
- Lead-free packages

In order to meet environmental requirements, ST offers these devices in different grades of ECOPACK[®] packages, depending on their level of environmental compliance. ECOPACK[®] specifications, grade definitions and product status are available at: www.st.com. ECOPACK[®] is an ST trademark.

Figure 4. HTSSOP-38 dimension definitions

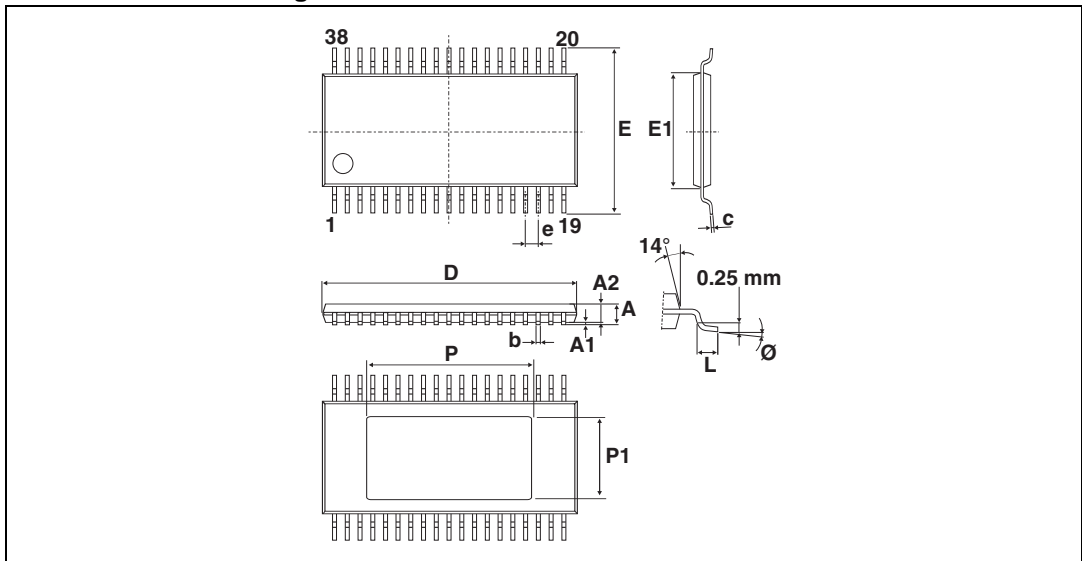
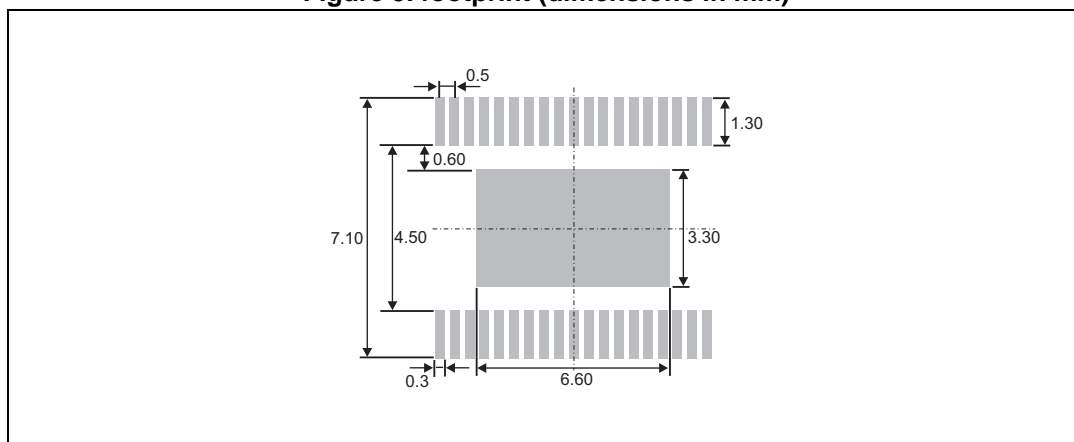

Table 2. HTSSOP-38 dimension values

Ref.	Dimensions					
	Millimeters			Inches		
	Min.	Typ.	Max.	Min.	Typ.	Max.
A	-	-	1.1	-	-	0.043
A1	0.05	-	0.15	0.002	-	0.006
A2	0.85	0.9	0.95	0.033	0.035	0.037
b	0.17	-	0.27	0.007	-	0.011
c	0.09	-	0.20	0.003	-	0.008
D	9.60	9.70	9.80	0.378	0.382	0.386
E1	4.30	4.40	4.50	0.169	0.173	0.177
e	-	0.50	-	-	0.020	-
E	-	6.40	-	-	0.252	-
L	0.50	0.60	0.70	0.020	0.024	0.027
P	6.40	6.50	6.60	0.252	0.256	0.260
P1	3.10	3.20	3.30	0.122	0.126	0.130
∅	0°	-	8°	0°	-	8°

Figure 5. footprint (dimensions in mm)



4 Ordering information

Figure 6. Ordering information scheme

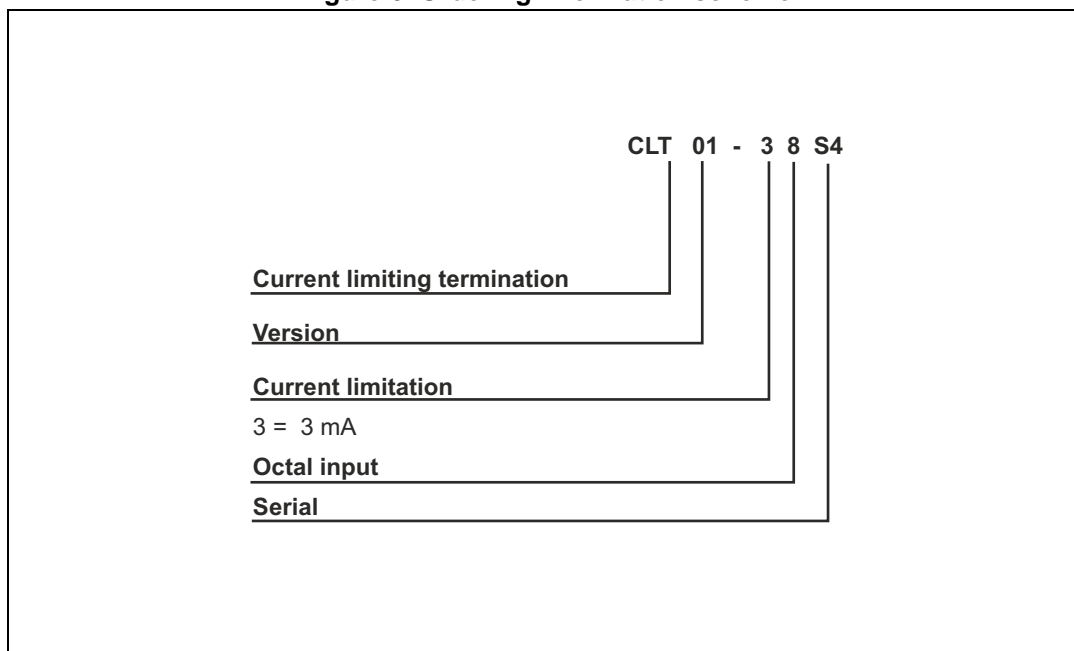

Table 3. Ordering information

Order code	Marking	Package	Weight	Base qty	Delivery mode
CLT01-38S4-TR	CLT01-38S4	HTSSOP-38	114 mg	2500	Tape and reel
CLT01-38S4	CLT01-38S4	HTSSOP-38	114 mg	40	Tube

5 Revision history

Table 4. Revision history

Date	Revision	Changes
23-Apr-2013	1	First issue