

OPERATION

The **CMB Series** relay is used to detect the presence of AC current. When the monitored current exceeds the trip point for longer than 30 milliseconds, the internal relay energizes. When the monitored current drops below the trip point for longer than 0.5 seconds, the internal relay de-energizes. The Delay-on-Release is incorporated to prevent nuisance tripping caused by momentary dips in the load line.

An External CT may be used to extend the range of the Current Monitor.

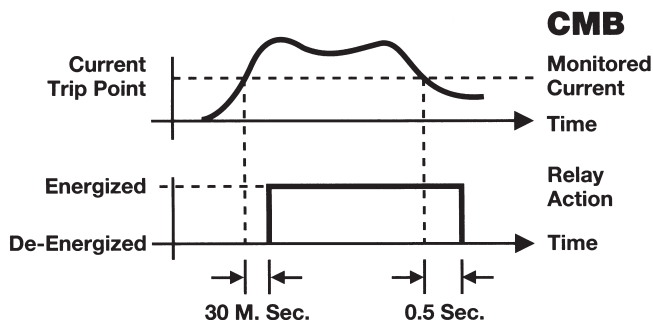

DIMENSIONS (INCHES)

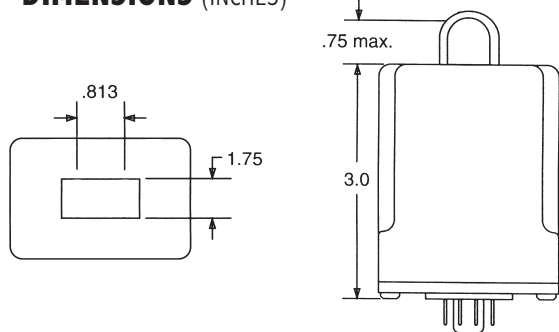

WIRING

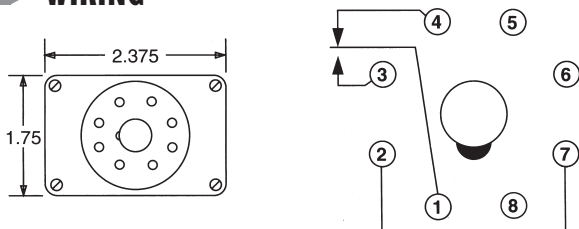

MODEL NUMBER

MODEL NUMBER	CMB			F	A	
CONTROL VOLTAGE						
24 Volts AC		24	A			
24 Volts DC (Not c [®] RU us)		24	D			
120 Volts AC		120	A			
CURRENT TRIP POINTS						
1 amp						1
2 amps						2
3 amps						3
4 amps						4
5 amps						5
6 amps						6
7 amps						7
8 amps						8
9 amps						9
10 amps						10



AC Go/No-Go Current Monitor/Relay

- Easy Installation
- No physical connection to the AC line that is being monitored
- Magnetically coupled by passing supply line through protruding Current Transformer
- 8-Pin, Plug-in

SPECIFICATIONS

CONTROL VOLTAGE	24 or 120 VAC; 50/60 Hz, 24 VDC	
TRIP POINTS	1-10 Amps, Fixed	
AC INPUT CURRENT	Up to 50 Amps	
OUTPUT	SPDT, 10 Amps @ 240 VAC Resistive; 211 VA @ 120 VAC Inductive: 1/6 Horsepower @ 120 VAC or 1/3 Horsepower @ 240 VAC	
POWER CONSUMPTION	3 Watts (Approximately)	
RESPONSE TIME	Operate	30 mSEC
	Release	0.5 SEC
LIFE EXPECTANCY	Mechanical	10 Million Operations (Minimum)
	Electrical	100,000 Operations @ Rated Load
DUTY CYCLE	Continuous	
TEMPERATURE RATING	Operate	32° to 131°F (0° to +55°C)
	Storage	-49° to 185°F (-45° to +85°C)
SOCKETS	RB-08 or PF083A	
ENCLOSURE	Lexan Dust Cover; 8-Pin plug-in	
WEIGHT	6 oz	