



CMD225C3

Passive Frequency Doubler, 4-8 GHz Input

Features

- ▶ Low conversion loss
- ▶ Excellent Fo isolation
- ▶ Broadband performance
- ▶ No bias required
- ▶ Pb-free RoHs compliant 3x3 mm SMT package

Description

The CMD225C3 die is a broadband MMIC GaAs x2 passive frequency multiplier housed in a leadless surface mount package. When driven by a +15 dBm signal, the multiplier provides 13 dB conversion loss at an output frequency of 12 GHz. The Fo and 3Fo isolations are >47 dBc and >54 dBc respectively. The CMD225C3 is a 50 ohm matched design eliminating the need for RF port matching.

Functional Block Diagram

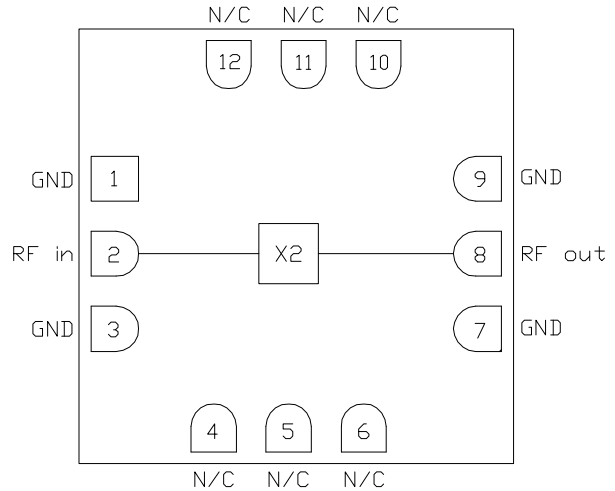

Electrical Performance - $T_A = 25\text{ }^\circ\text{C}$, $P_{in} = +15\text{ dBm}$, $F_{in} = 6\text{ GHz}$

Parameter	Min	Typ	Max	Units
Frequency Range, Input	4 - 8			GHz
Frequency Range, Output	8 - 16			GHz
Conversion Loss		13		dB
Fo Isolation (with respect to input level)		47		dB
3Fo Isolation (with respect to input level)		54		dB
4Fo Isolation (with respect to input level)		50		dB



CMD225C3

Passive Frequency Doubler, 4-8 GHz Input

Specifications

Absolute Maximum Ratings

Parameter	Rating
RF Input Power	+27 dBm
Operating Temperature	-55 to 85 °C
Storage Temperature	-55 to 150 °C

Operation of this device outside the maximum ratings may cause permanent damage.

Electrical Specifications - $T_A = 25\text{ °C}$, $P_{in} = +15\text{ dBm}$

Parameter	Min	Typ	Max	Min	Typ	Max	Units
Frequency Range, Input	4 - 8			5 - 7			GHz
Frequency Range, Output	8 - 16			10 - 14			GHz
Conversion Loss		13	20		13	17	dB
Fo Isolation (with respect to input level)	33	48		38	48		dB
3Fo Isolation (with respect to input level)	41	50		41	50		dB
4Fo Isolation (with respect to input level)	23	50		33	50		dB

ver 1.1 1017

Typical Performance

Conversion Gain vs. Temperature @ +15 dBm Drive Level

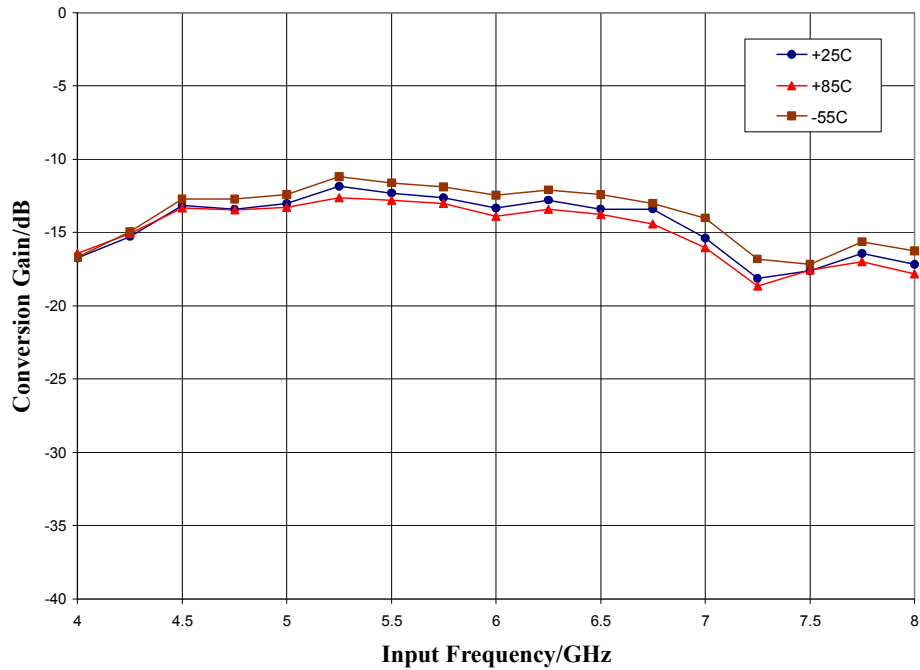

Conversion Gain vs. Drive Level, $T_A = 25\text{ }^\circ\text{C}$

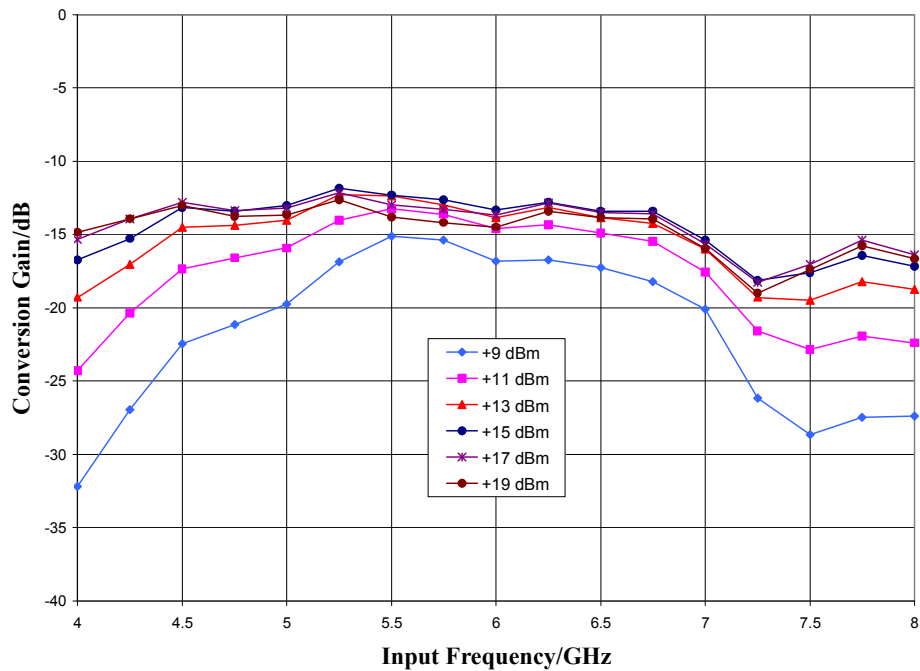

ver 1.1 1017

Typical Performance

Isolation (with respect to input level) @ +15 dBm Drive Level, T_A = 25 °C

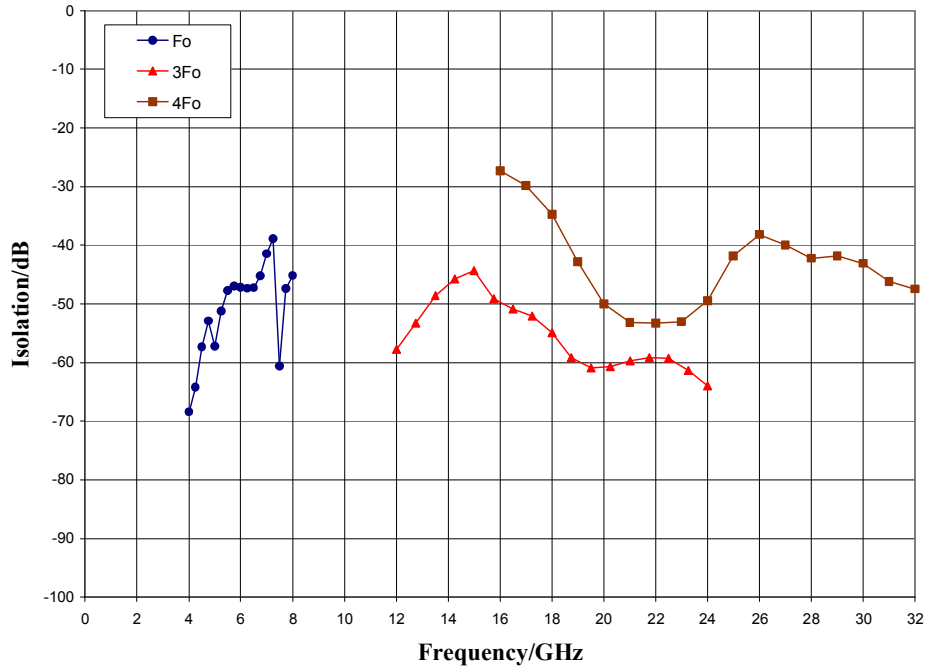

Input Return Loss @ +15 dBm Drive Level, T_A = 25 °C

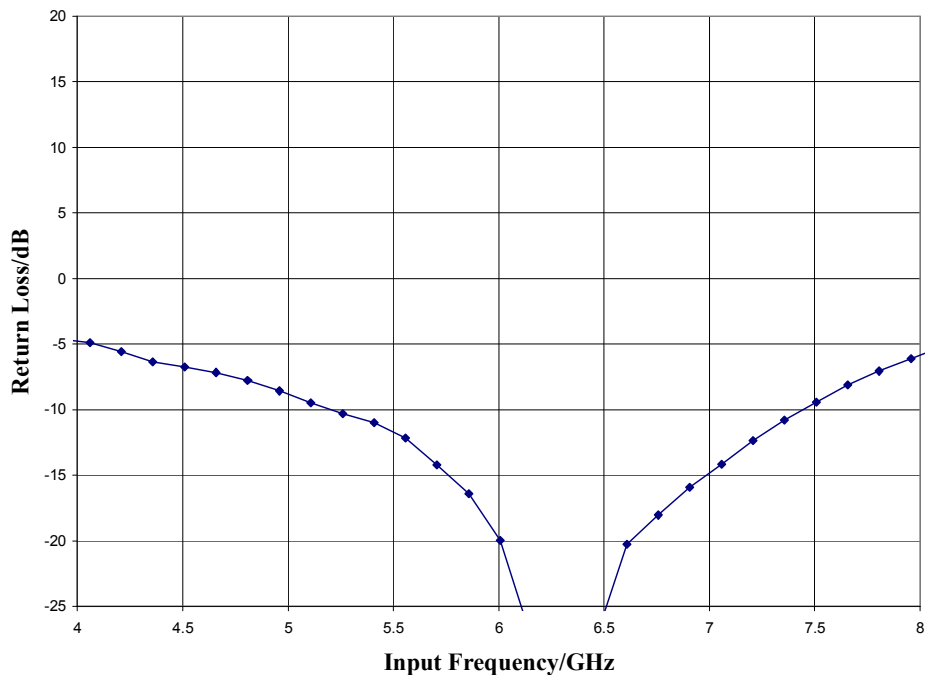

ver 1.1 1017



CMD225C3

Passive Frequency Doubler, 4-8 GHz Input

Typical Performance

Output Return Loss @ +15 dBm Drive Level, F = 6 GHz Input, T_A = 25 °C

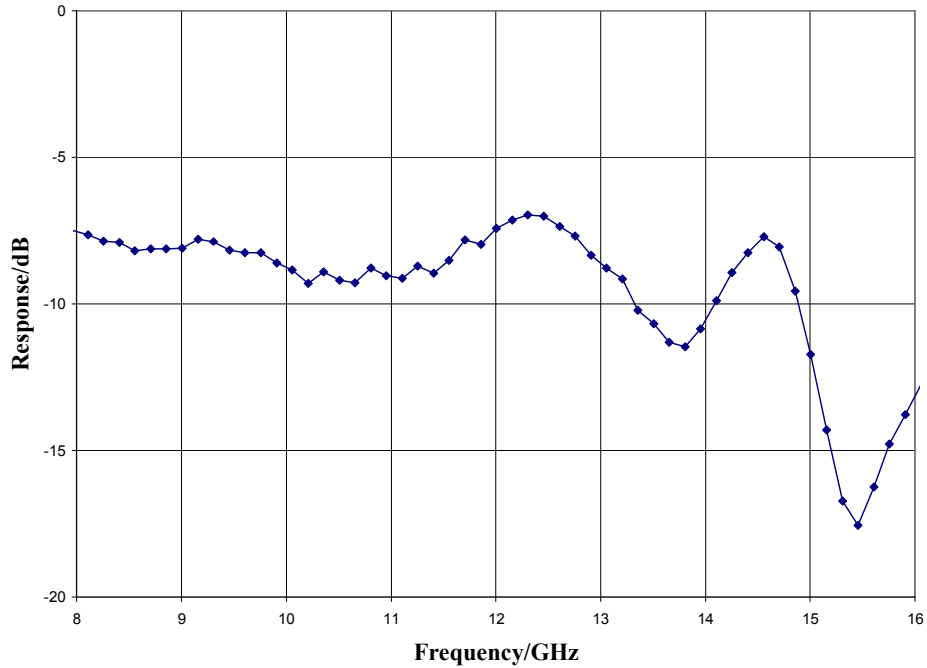

ver 1.1 1017

Mechanical Information

Package Information and Dimensions

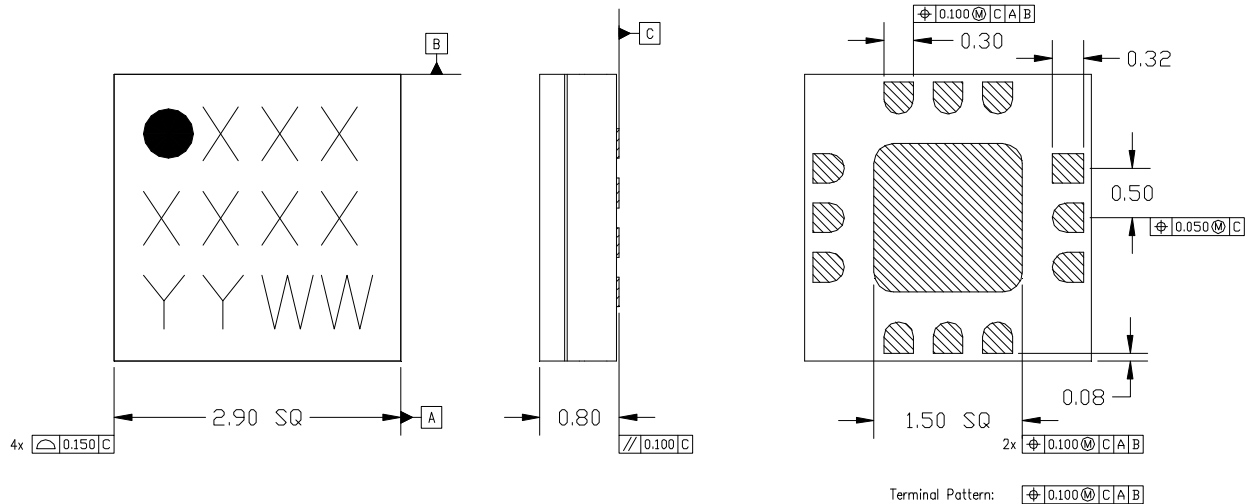

- NOTES:
1. ALL DIMENSIONS SHOWN IN mm.
 2. MATERIAL: BLACK ALUMINA
 3. LEAD FINISH:
 - 3.1. Ni: 8.89 μ m MAX, 1.27 μ m MIN
 - 3.2. Pd: 0.17 μ m MAX, 0.07 μ m MIN
 - 3.3. Au: 0.254 μ m MAX, 0.03 μ m MIN
 4. MARKING
 - 4.1. LINE 1: PART NUMBER
 - 4.1.1. EXAMPLE: CMD177C3 SHALL BE MARKED AS 177
 - 4.2. LINE 2: LDT NUMBER
 - 4.3. LINE 3: DATE CODE - LAST 2 DIGITS OF THE YEAR OF MANUFACTURE FOLLOWED BY A 2 DIGIT WEEK CODE
 5. ALTERNATE PIN #1 IDENTIFIER IS A SINGLE SQUARE PAD
 6. ALTERNATE DIE PADDLE MAY HAVE CHAMFERED CORNERS

Recommended PCB Land Pattern

Custom MMIC Design Services recommends that the user develop the land pattern that will provide the best design for proper solder reflow and device attach for their specific application. Please review Custom MMIC Application Note AN 105 for a recommended land pattern approach.

Recommended Solder Reflow Profile



Custom MMIC Design Services recommends screen printing with belt furnace reflow to ensure proper solder reflow and device attach. Please review Custom MMIC Application Note AN 102 for a recommended solder reflow profile.

Pin Description

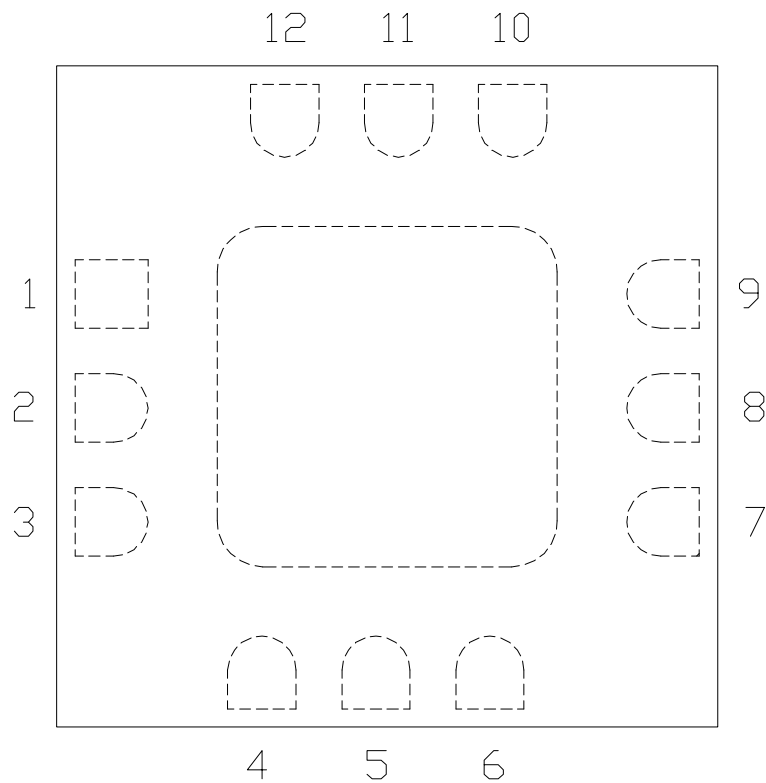
Pin Diagram



Functional Description

Pad	Function	Description	Schematic
1, 3, 7, 9 and die paddle	Ground	Connect to RF / DC ground	
2	RF in	Pin is DC coupled and 50 ohm matched	
4-6, 10-12	N/C	No connection required. These pins may be connected to RF/DC ground	
8	RF out	Pin is DC coupled and 50 ohm matched	

ver 1.1 1017