

Features

- ▶ Low loss broadband performance
- ▶ High isolation
- ▶ Fast switching speed
- ▶ Reflective design
- ▶ Small die size

Description

The CMD230 is a general purpose broadband high isolation reflective MMIC SPDT switch in die form. Covering DC to 26 GHz, the CMD230 features a low insertion loss of 1.4 dB and high isolation of 40 dB at 13 GHz. The CMD230 operates using complementary control voltage logic lines of 0/-5 V and requires no bias supply.

Functional Block Diagram

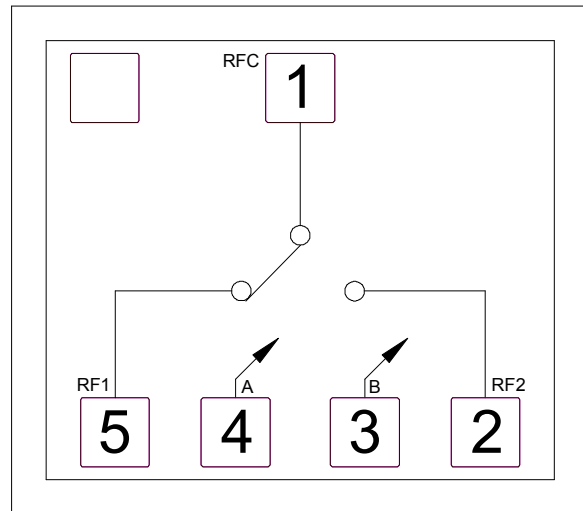

Electrical Performance - $V_{ctl} = 0/-5\text{ V}$, $T_A = 25\text{ }^\circ\text{C}$, $F = 13\text{ GHz}$

Parameter	Min	Typ	Max	Units
Frequency Range	DC - 26			GHz
Insertion Loss		1.4		dB
Isolation		40		dB
Return Loss - RFC		16		dB
Return Loss RF1, RF2 - On State		27		dB
Input P0.1dB		21		dBm
Switching Speed		3.4		ns

Specifications

Absolute Maximum Ratings

Parameter	Rating
RF Input Power	+30 dBm
Control Voltage Range (A,B)	+0.5V to -7.5V
Channel Temperature, T _{ch}	150 °C
Operating Temperature	-55 to 85 °C
Storage Temperature	-55 to 150 °C

Operation of this device outside the maximum ratings may cause permanent damage.

Control Voltages

State	Bias Condition
Low	0 to -0.5V @ 0.01 uA Typ
High	-2V @ 0.1 uA Typ to -7V @ 20 uA Typ

Truth Table

Control Input		Signal Path State	
A	B	RFC to RF1	RFC to RF2
High	Low	On	Off
Low	High	Off	On

Electrical Specifications - V_{ctl} = 0/-5 V, T_A = 25 °C

Parameter	Min	Typ	Max	Min	Typ	Max	Min	Typ	Max	Units
Frequency Range	DC - 8			DC - 18			DC - 26			GHz
Insertion Loss		1.1	1.5		1.7	2.1		2.4	2.8	dB
Isolation	39	44		32	37		27	32		dB
Return Loss - RFC		18			13			11		dB
Return Loss - RF1, 2 - On State		21			17			12		dB
Input P0.1dB		23			21			21		dBm
Input IP3		38			37			35		dBm
Switching Speed		3.4			3.4			3.4		ns

ver 1.1 0616

Typical Performance

Insertion Loss vs. Temperature

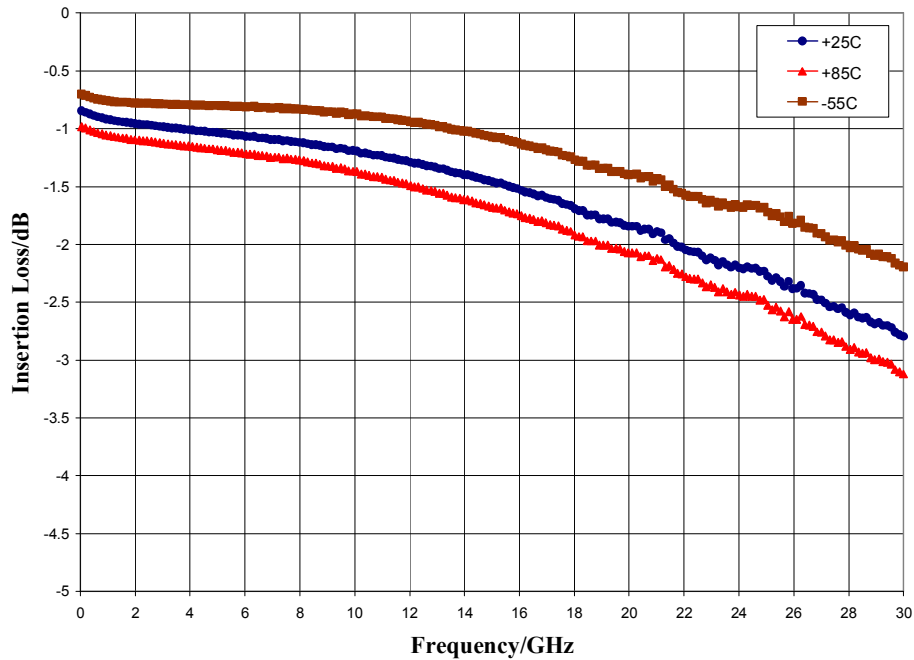

Return Loss

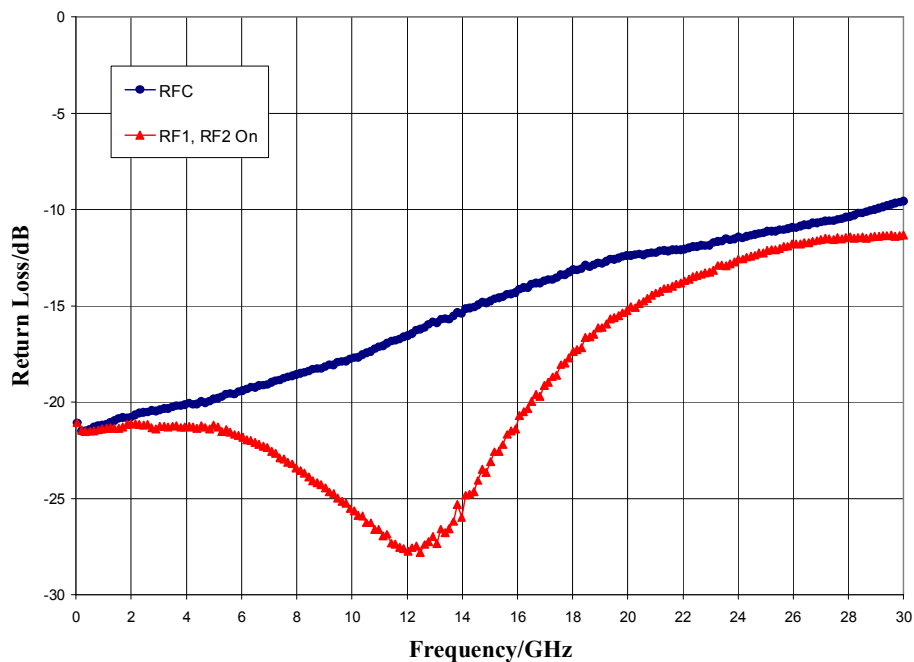

ver 1.1 0616

Typical Performance

Isolation Between Ports RFC and RF1/RF2

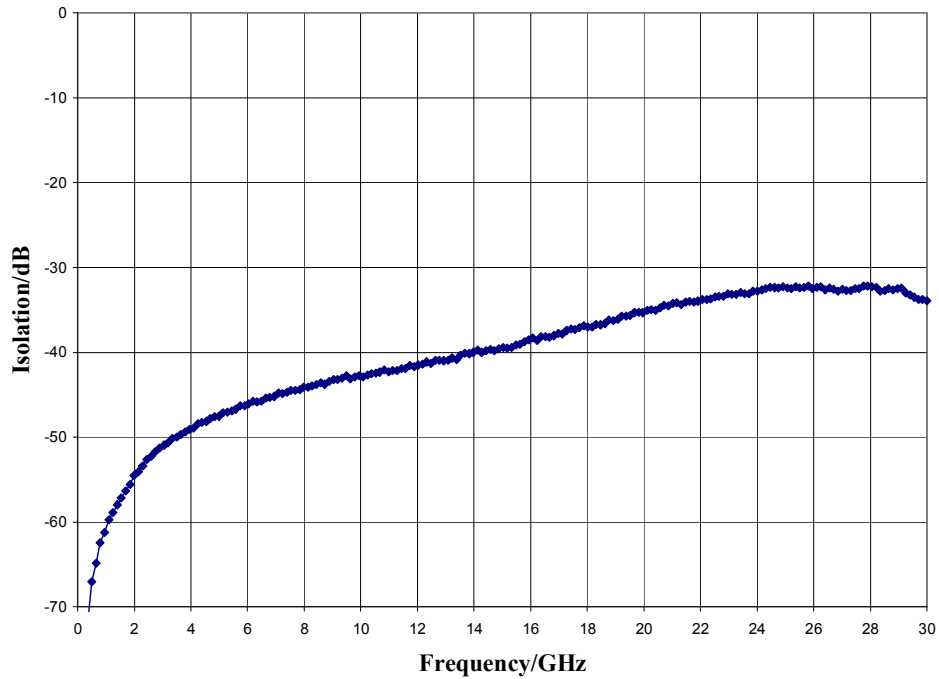

Input P0.1dB Compression Point and Input Third Order Intercept Point

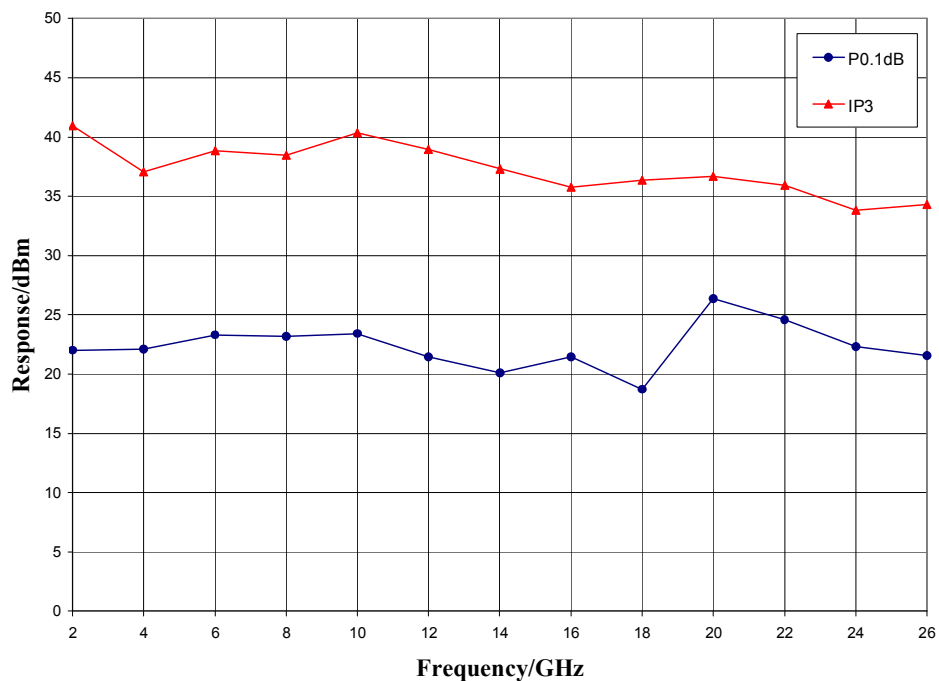

ver 1.1 0616

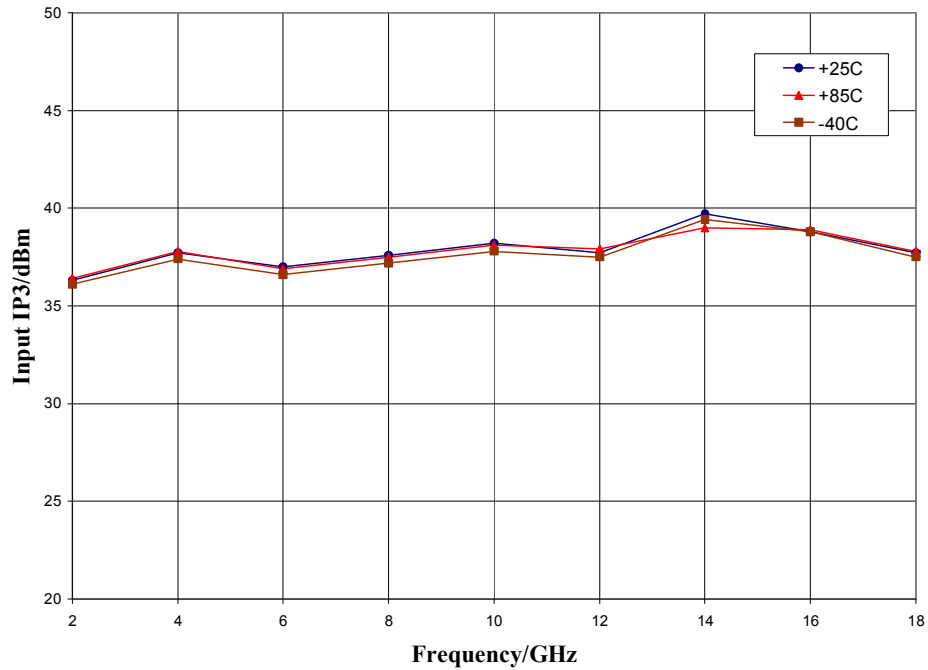
*Typical Performance***Input Third Order Intercept Point**

Mechanical Information

Die Outline (all dimensions in microns)

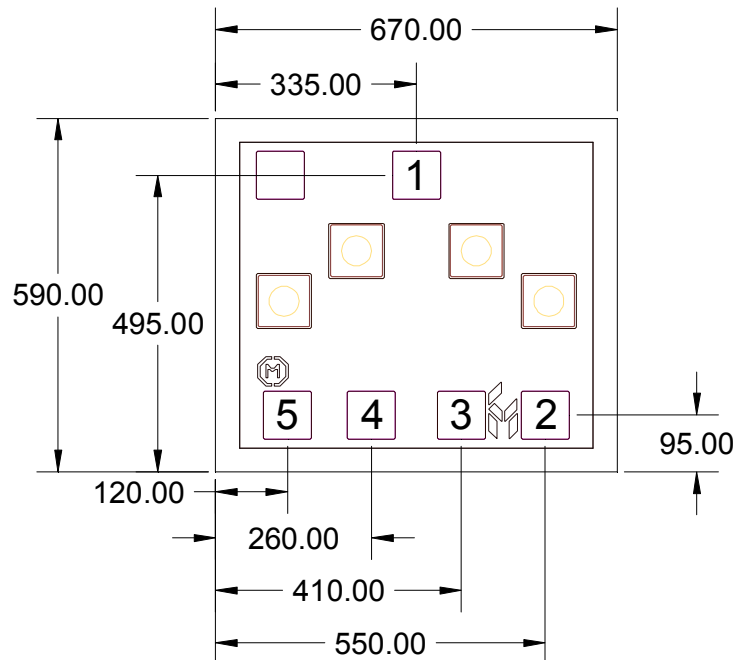

Notes:



1. No connection required for unlabeled pads
2. Backside is RF and DC ground
3. Backside and bond pad metal: Gold
4. Die is 100 microns thick
5. DC bond pads are 100 microns square

Pad Description

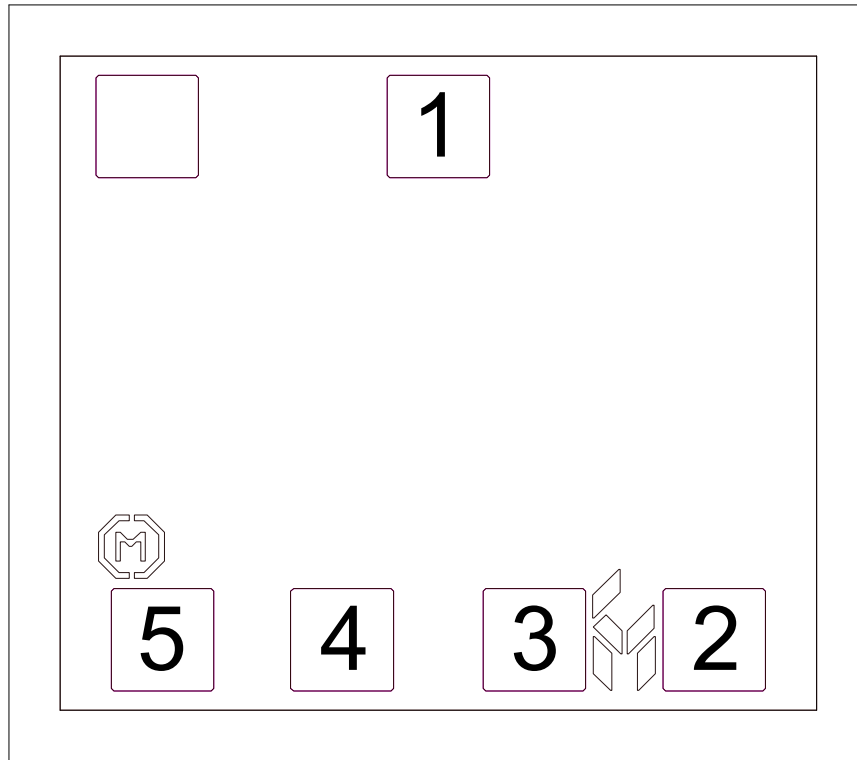
Pad Diagram

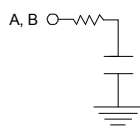

Functional Description

Pin	Function	Description	Schematic
1, 2, 5	RFC, RF2, RF1	These pins are DC coupled and matched to 50 Ohm. Blocking capacitors are required if RF line potential is not equal to 0V	
4	CTRLA	See truth table and control voltage table	
3	CTRLB	See truth table and control voltage table	
Backside	Ground	Connect to RF / DC ground	

ver 1.1 0616

Applications Information

Suggested Driver Circuit

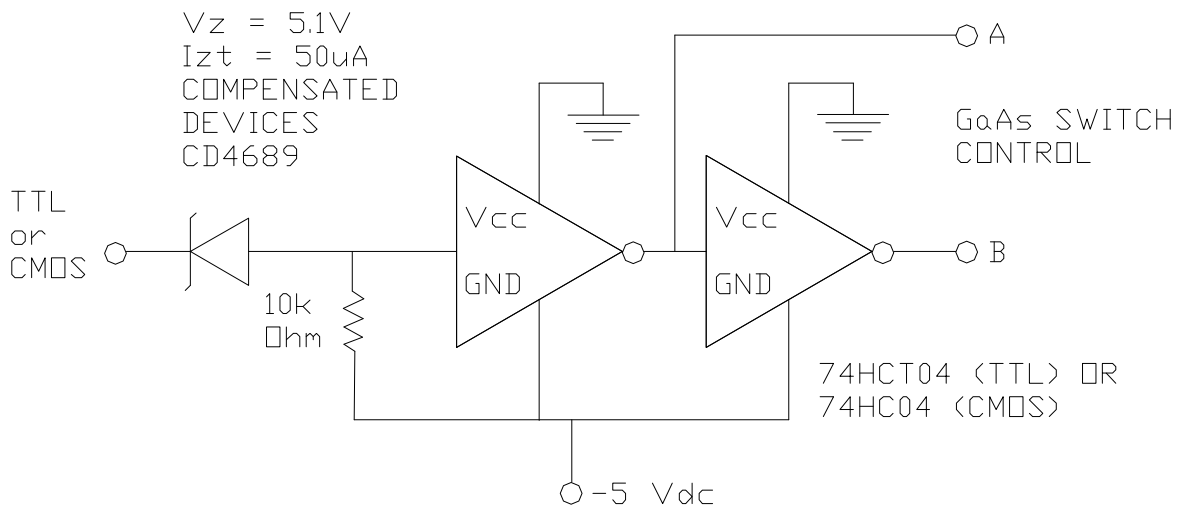

GaAs MMIC devices are susceptible to damage from Electrostatic Discharge. Proper precautions should be observed during handling, assembly and test.

ver 1.1 0616